

FEATURES

Isolated Frequency Input.

Amplifies, Protects, Filters, and Isolates Analog Input.
Generates an output of 0 to +5V proportional to input frequency.

Model 5B45 accepts full-scale inputs from 500 Hz to 20 kHz.

Model 5B46 accepts full-scale input from 20 KHz to 275 kHz.

Module circuitry can withstand 240v rms at the input screw-terminals.

All 5B45 & 5B46 series modules are mix-and-match and Hot Swappable.

APPLICATIONS

Industrial signal conditioning

Industrial signal isolation

Industrial signal filtering

PRODUCT OVERVIEW

The 5B Series represents an innovative generation of low cost, high performance plug-in signal conditioners. Designed for industrial applications, these modules incorporate highly reliable transformer-based isolation and automated surface-mount manufacturing technology. They are compact, economical components whose performance exceeds that available from more expensive devices. Combining 1500 V rms continuous isolation, +0.05% calibrated accuracy, small size and low cost, the 5B Series is an attractive alternative to expensive signal conditioners and in-house designs

All modules are potted and identical in pin-out and size (2.27" x 2.32" x 0.595"). They can be mixed and matched, permitting users to address their exact needs, and may be "hot swapped" without disturbing field wiring or power. The isolated input modules provide 0 to +5V or +5V outputs and accept J, K, T, E, R, S, N, or B type thermocouples.

These modules feature complete signal conditioning functions including 240 V rms input protection, filtering, chopper stabilized low drift +1 uV/oC amplification, 1500 V rms isolation, and sensor excitation when required.

All modules feature excellent common mode rejection and meet industrial transient surge withstand specifications.

Rev. 0

Information furnished by Analog Devices is believed to be accurate and reliable. However, no responsibility is assumed by Analog Devices for its use, nor for any infringements of patents or other rights of third parties that may result from its use. Specifications subject to change without notice. No license is granted by implication or otherwise under any patent or patent rights of Analog Devices. Trademarks and registered trademarks are the property of their respective companies.

FUNCTIONAL BLOCK DIAGRAM

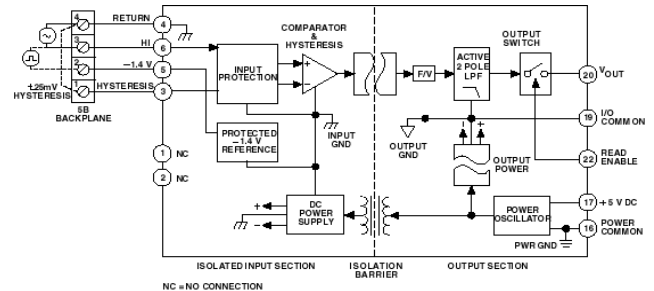

Figure 1. 5B45 & 5B46 Functional Block Diagram

There are also a number of backplanes and mounting sockets which provide a complete signal conditioning solution for end users. Each backplane incorporates screw terminals for field wiring inputs and outputs and cold junction sensors for thermocouple applications.

These signal conditioners are designed to provide an easy and convenient solution to signal conditioning problems of both designers and end users in measurement and control applications. Typical uses include microcomputer-based measurement systems, standard data acquisition systems, programmable controllers, analog recorders and dedicated control systems. The 5 B series modules are ideally suited to applications where monitoring and control of temperature, pressure, flow, rotation and other analog signals are required.

The 5B Series modules and backplanes are approved by Factory Mutual (FM) and the 5B Series modules are approved by the Canadian Standards Association (CSA) for use in Class 1, Division 2, Groups A, B, C, and D locations. These approvals certify that the 5B Series is suitable for use in locations where a hazardous concentration of flammable gas may exist only under fault conditions of operation. Equipment of this category is called "nonincendive" and they need no special enclosures or other physical safeguards.

The 5B series modules and backplanes have been tested and passed the stringent heavy industrial requirements of the European Union's electromagnetic compatibility (EMC) directive – EN50082-1 and EN50081-2. When used according to installation directions (refer to 5B series User Manual), any errors caused by EMI/RFI interference will be less than 0.1% of the full scale 5B measurement range for field strengths up to 10 V/M and frequencies up to 1 GHz.

GENERAL DESCRIPTION

The 5B45 and 5B46 are single-channel isolated frequency input modules that produce a 0 to +5V output proportional to input frequency. Model 5B45 accepts full-scale inputs ranging from 500 Hz to 20 kHz. Model 5B46 accepts full-scale inputs ranging from 20 kHz to 275 kHz. Both models allow the user to set the threshold to either 0 V (for zero crossing signals) or +1.4 V (for positive level signals), and the hysteresis to either +25 mV or +400 mV (all input types).

The 5B45 and 5B46 protect the computer side from field-side over-voltage faults. All models withstand 240 V rms at their input terminals without damage, thereby shielding computer-side circuitry from field-side over-voltage conditions. In addition, all 5B45 and 5B46 models are mix-and match and hot-swappable, so can be inserted or removed from any socket in the same backplane without disrupting system power.

Inside 5B45 & 5B46 Modules – The 5B45/46 internal circuitry compares the input signal to the user-selected threshold (V_T) and hysteresis (V_H). Signals of virtually any wave shape that exceed the combined threshold and hysteresis levels ($V_T \pm V_H$) will trigger a comparator at a rate determined by the input frequency. The comparator output is then transmitted across a proprietary transformer-coupled isolation barrier and converted to a high-level analog signal. This signal is then filtered by a multi-pole low pass Butterworth filter and buffered

to provide a low-noise, low-impedance output signal that is accurately proportional to input frequency.

Simple Setup and Versatile Choices – Setting the threshold and hysteresis values is a simple matter of externally wiring to the backplane screw terminals. The threshold for measuring a zero-crossing voltage waveform (such as sine waves) is set to 0 volts by connecting the input signal across screw-terminals 4 and 3. The threshold for a positive level signal (such as a TTL or pulse train waveform) is set at +1.4V by connecting the input signal across terminals 3 and 2. Hysteresis for both input signal types is set at ± 400 mV but can be changed to ± 25 mV by adding a jumper between screw terminals 1 and 4. Response time is a function of a modules rated input frequency range. (See the 5B45 and 5B46 Model Table).

The input circuit is fully floating and isolated from the output and power commons. In addition, the output section acts as a third floating port towards eliminating possible problems from ground loops and power supply noise. The output common must be held within $\pm 3V$ of power common.

A series output switch eliminates the need for external multiplexing in many applications. The switch is turned on by an active-low enable input. If the switch is to be on at all times, the enable-input should be grounded to power common as it is on the 5B01 and 5B08 backplanes..



Figure 2

5B45 and 5B46 Models Available

Model	Input Range	Output Range	Rise/Fall Time	Step Response
5B45-01	0 Hz to 500 Hz	0 V to +5 V	80 ms	150 ms
5B45-02	0 Hz to 1 kHz	0 V to +5 V	60 ms	140 ms
5B45-03	0 Hz to 2.5 kHz	0 V to +5 V	50 ms	130 ms
5B45-04	0 Hz to 5 kHz	0 V to +5 V	50 ms	130 ms
5B45-05	0 Hz to 10 kHz	0 V to +5 V	50 ms	130 ms
5B45-Custom	*	*		

Model	Input Range	Output Range	Rise/Fall Time	Step Response
5B46-01	0 Hz to 25 kHz	0 V to +5 V	15 ms	44 ms
5B46-02	0 Hz to 50 kHz	0 V to +5 V	7 ms	22 ms
5B46-03	0 Hz to 100 kHz	0 V to +5 V	4 ms	12 ms
5B46-04	0 Hz to 250 kHz	0 V to +5 V	4 ms	9 ms
5B46-Custom	*	*		

* Custom Input/Output ranges are available. Refer to configuration guide.

5B45 and 5B46 Specifications

Description	Model 5B45	Model 5B46
	Frequency Input	
Standard Ranges	Refer to Model Table	Refer to Model Table
Custom Ranges	500 Hz span, min.; 20 kHz span, max.	20 kHz span, min.; 275 kHz span, max.
Over-range	20% of Span	*
Voltage Range	70 mV rms min. 240 V rms max.	*
Waveforms	Sine, Square, Triangle, Pulse Train	*
Pulse Width (Pulse Train Inputs)	2 μ s min.	*
Threshold Options	Zero Crossing or TTL (+1.4 V)	*
TTL Input, Low (-40°C to +85°C)	0.8 V max.	*
TTL Input, High (-40°C to +85°C)	2.0 V min.	*
Hysteresis Options ¹	± 25 mV or ± 400 mV	*
Output Ranges ($R_L > 50$ kΩ)	-5 V to +5 V or 0 V to +5 V	*
	Accuracy²	
Initial @ +25°C	$\pm 0.05\%$ Span ($\pm 0.1\%$ Span, max.)	*
Nonlinearity	$\pm 0.005\%$ Span ($\pm 0.015\%$ Span, max.)	*
Output Offset vs. Temperature	± 20 μ V/°C	*
Gain vs. Temperature	± 20 ppm/°C	*
Input Bias Current, $V_{in} < 5$ V peak-peak	100 μ A	*
	Input Impedance	
Small Signal, $V_{in} < 5$ V peak-peak	5 M Ω	*
Large Signal, $V_{in} > 5$ V peak-peak	40 k Ω 330 pF	*

Power Off	40 k Ω 330 pF	*
Noise		
Output, 100 kHz Bandwidth	0.7 mV peak-peak	*
Output, 5 MHz Bandwidth	7 mV peak-peak	*
Output Ripple	10 mV peak-peak @ (10% F_{span} + $F_{full\ scale}$)	*
Bandwidth, -3 dB	10 Hz	190 Hz
Output Step Response Time	Refer to Model Table	*
Common-Mode Voltage (CMV)		
Input-to-Output, Continuous	1500 V rms, maximum	*
Output-to-Power, Continuous ³	± 3 V, maximum	*
Transient	ANSI/IEEE C37.90.1-1989	*
Common-Mode Rejection (CMR)		
1 k Ω Source Imbalance, 50/60 Hz	120 dB	*
Input Protection		
Continuous	240 V rms, maximum	*
Transient	ANSI/IEEE C37.90.1-1989	*
Output Resistance	50 Ω	*
Voltage Output Protection	Continuous Short to Ground	*
Output Selection Time	6 μ s @ $C_{load} = 0$ to 2,000 pF	*
Output Enable Control		
Max Logic "0"	+1.0 V	*
Min Logic "1"	+2.5 V	*
Max Logic "1"	+36 V	*
Input Current "0"	0.4 mA	*
Power Supply Voltage	+5 V $\pm 5\%$	*
Power Supply Current	70 mA	*
Power Supply Sensitivity, RTO	$\pm 0.005\%$ of Span/% of V_s	*
Mechanical Dimensions	2.275" x 2.375" x 0.595" (57.8 mm x 59.1 mm x 15.1 mm)	*
Environmental		
Temperature Range		
Rated Performance	-40°C to +85°C	*
Operating Performance	-40°C to +85°C	*
Storage	-40°C to +85°C	*
Relative Humidity	0 to 93% @ +40°C non-condensing	*
RFI Susceptibility	$\pm 0.5\%$ Span error @ 400 MHz, 5 Watt, 3 ft	*

* Specifications same as model 5B45.

¹ Jumper selectable. Refer to Field Connection diagram.

² Includes the combined effects of repeatability, hysteresis, and nonlinearity. Loads heavier than 50 k Ω will degrade nonlinearity and gain temperature coefficient.

³ The Output Common must be kept within ± 3 V of Power Common.

Specifications subject to change without notice.

PIN CONFIGURATIONS AND FUNCTIONAL DESCRIPTIONS

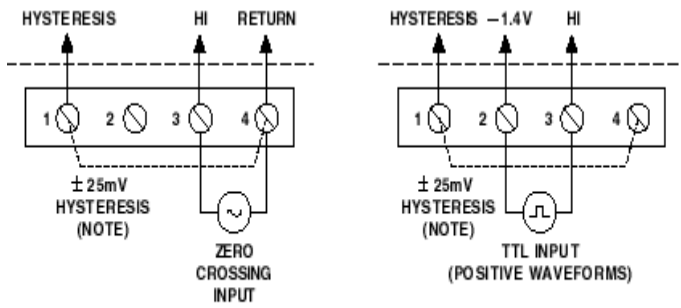

NOTE: HYSTERESIS IS $\pm 400\text{mV}$ WHEN NOT CONNECTED

Figure 3 5B45 & 5B46 Input Field Connections

Table 1. Pin Function Descriptions—

Pin No.	Description
1	HYSTERESIS
2	-1.4V
3	HI
4	RETURN

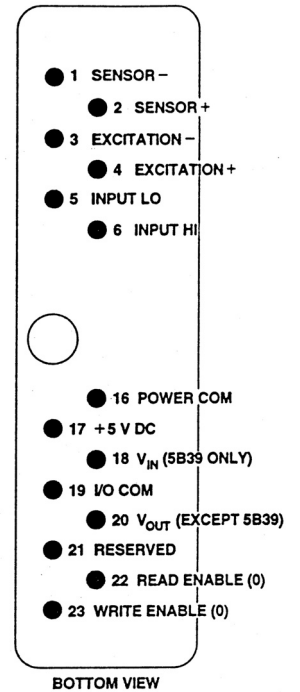
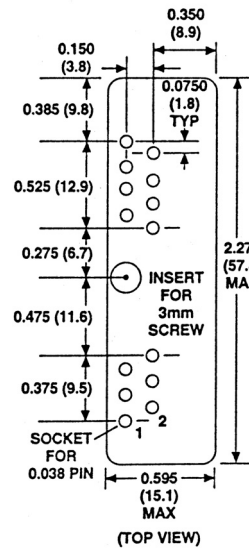

Figure 4 . Model 5B Series Module, with pin-out assignments.

ESD CAUTION

ESD (electrostatic discharge) sensitive device. Electrostatic charges as high as 4000 V readily accumulate on the human body and test equipment and can discharge without detection. Although this product features proprietary ESD protection circuitry, permanent damage may occur on devices subjected to high energy electrostatic discharges. Therefore, proper ESD precautions are recommended to avoid performance degradation or loss of functionality.



OUTLINE DIMENSIONS

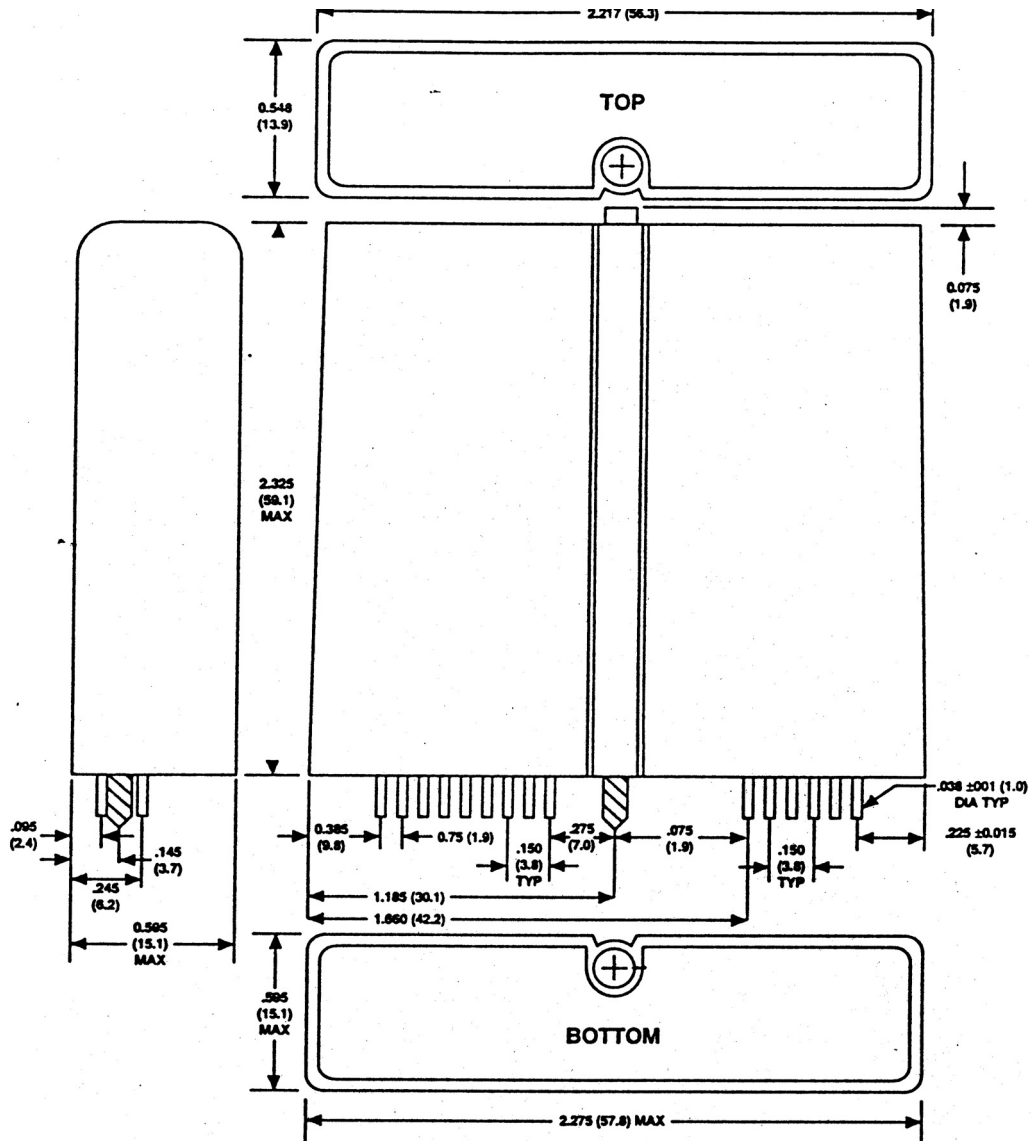

Figure 5. Outline Dimensions

NOTES

NOTES