

RS-232 to RS-422 Self-Powered Converter CE Model 422LPCON

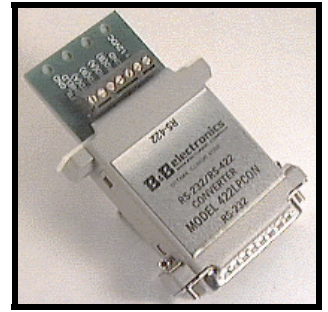



This RS-232 to RS-422 converter converts unbalanced RS-232 signals to balanced RS-422 signals. The power used for this converter is derived from the transmit data line (pin 2) and the handshake control lines (pins 4, 5, 6, 8, and 20). The converter can derive power from these lines when they are in the positive or negative voltage state. This permits the converter to be used in applications without any regard to software control of the handshake lines. If no handshake lines are available and all power must be derived from the transmit data line, the converter can drive limited cable lengths. A guide for this condition would be to drive only several hundred feet of transmission line and not to terminate the transmission line with a resistor of less than 1000 ohms. When more handshake lines are available longer lengths of cable can be driven. This converter has been tested at 115.2k baud with 4000 feet of cable. For applications where handshake lines are not available and long cable runs are involved, an external power supply can be connected to the terminal blocks on the RS-422 side of the converter marked "+12V" and "GND".

NOTE: When using an external supply, the supply should be connected only to specifically labeled power inputs (power jack, terminal block, etc.). Connecting an external power supply to the handshake lines may damage the unit. Contact technical support for more information on connecting an external power supply to the handshake lines.

The RS-232 port uses a male DB25 type of connector with pins 2 (TD input) and 3 RD(RD output) supported. Signal Ground (pin 7) is connected through to the RS-422 side on the terminal block marked "GND".

Interconnection of the converter with another RS-422 device:

1. The polarity of the two RS-422 lines must be correct. With no data being sent, the RS-232 line should be negative and the RS-422 "A" terminal should be negative with respect to the "B" terminal.
2. The wire recommended in the RS-422 Standard is number 24 AWG copper conductor, twisted-pair telephone cable with a shunt capacitance of 16 per foot.
3. For long runs and/or high data rates, it is recommended that the wires be terminated with a resistor at the receive end. The twisted pair usually used has an impedance of about 100 ohms, therefore a 100 ohm resistor is normally used for the termination. The RS-422 side of the converter requires more power as the transmission line is increased and as the termination resistor value is reduced, therefore it may be necessary to use a termination resistor that is larger than 100 ohms.
4. The RS-422 driver has the ability to drive ten RS-422 receivers connected in parallel. A system of multiple receivers may require some experimentation with location and size of termination resistors, line lengths, grounding, etc.

DECLARATION OF CONFORMITY	
Manufacturer's Name:	B&B Electronics Manufacturing Company
Manufacturer's Address:	P.O. Box 1040 707 Dayton Road Ottawa, IL 61350 USA
Model Numbers:	422LPCON
Description:	Port-Powered 2-Channel RS-422 Converter
Type:	Light industrial ITE equipment
Application of Council Directive:	89/336/EEC
Standards:	EN 50082-1 (IEC 801-2, IEC 801-3, IEC 801-4) EN 50081-1 (EN 55022, IEC 1000-4-2) EN 61000 (-4-2, -4-3, -4-4, -4-5, -4-6, -4-8, -4-11) ENV 50204 EN 55024
	
Michael J. Fahrion, Director of Engineering	
	

© B&B Electronics -- Revised November 2000

This product designed and manufactured in USA of domestic and imported parts by

B & B Electronics Mfg. Co.

707 Dayton Road - P.O. Box 1040 - Ottawa, IL 61350 USA

Phone: (815) 433-5100 - Fax: (815) 433-5105

Home Page: www.bb-elec.com

Sales e-mail: orders@bb-elec.com - Fax: (815) 433-5109

Technical Support e-mail: support@bb-elec.com - Fax: (815) 433-5104

B & B Electronics Ltd

Westlink Commercial Park - Oranmore, Co. Galway - Ireland

Phone: +353 91 792444 - Fax: +353 91 792445

Home Page: www.bb-europe.com

Sales e-mail: orders@bb-europe.com

Technical Support e-mail: support@bb-europe.com

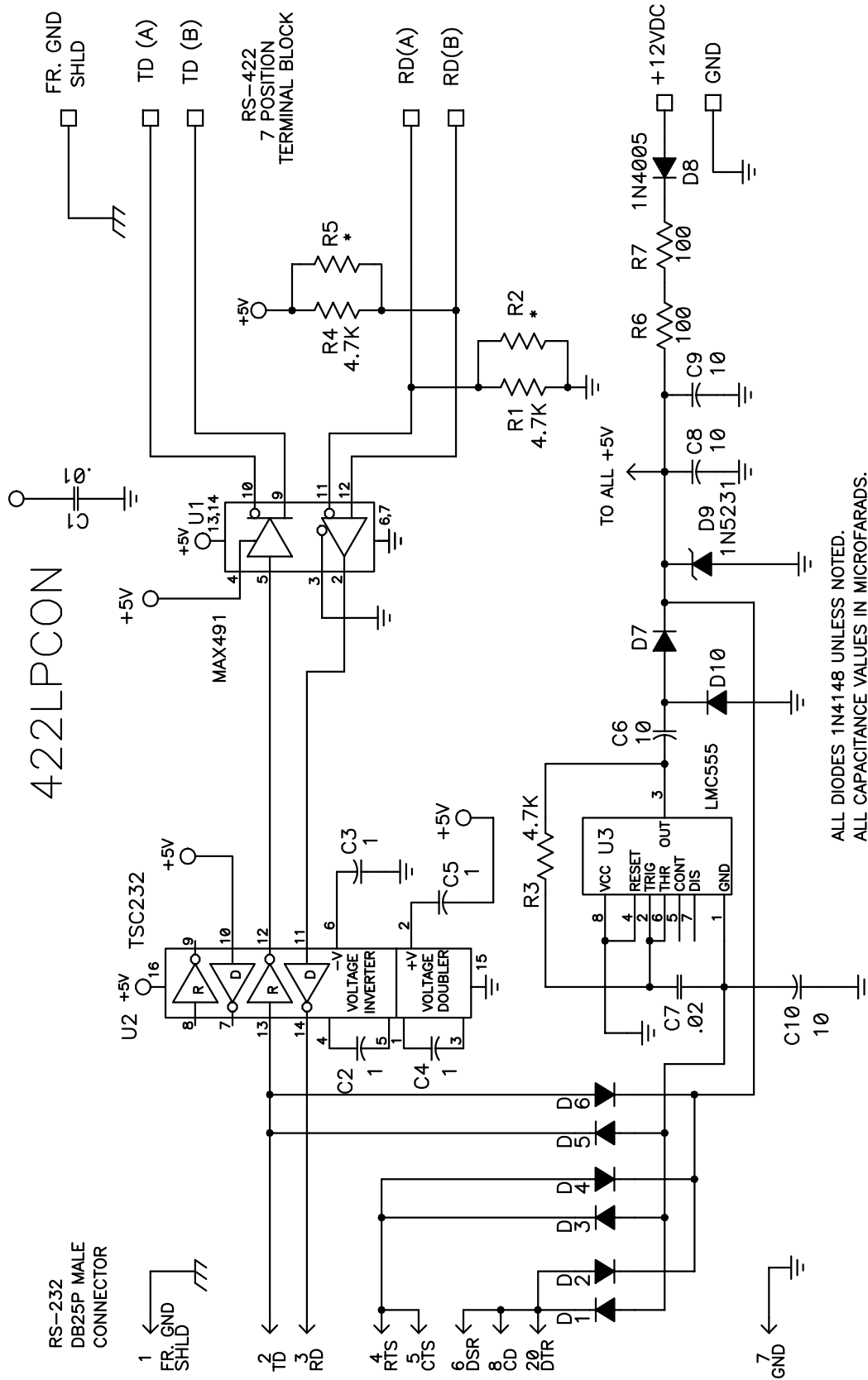

ALL DIODES 1N4148 UNLESS NOTED.
 ALL CAPACITANCE VALUES IN MICROFARADS.
 * THROUGH-HOLE RESISTORS NOT STUFFED

© B&B Electronics -- Revised November 2000

This product designed and manufactured in USA of domestic and imported parts by

B & B Electronics Mfg. Co.

707 Dayton Road - P.O. Box 1040 - Ottawa, IL 61350 USA
 Phone: (815) 433-5100 - Fax: (815) 433-5105

Home Page: www.bb-elec.com

Sales e-mail: orders@bb-elec.com - Fax: (815) 433-5109

Technical Support e-mail: support@bb-elec.com - Fax: (815) 433-5104

B & B Electronics Ltd

Westlink Commercial Park - Oranmore, Co. Galway - Ireland
 Phone: +353 91 792444 - Fax: +353 91 792445

Home Page: www.bb-europe.com

Sales e-mail: orders@bb-europe.com

Technical Support e-mail: support@bb-europe.com