

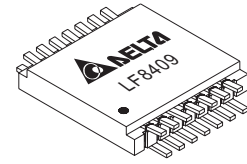

FAST ETHERNET 100BASE-TX PCMCIA TRANSFORMER MODULES

Networking Components



ELECTRICAL CHARACTERISTICS @25°C

| Rise Time & Fall Time @5.0ns (Max), Hi-Pot Test @60Sec, 1500Vrms, OCL @8mA DC Bias 350uH (Min) | | | | | | | | | | | | | | |
|--|-------------------------|----------------------|------|-------|-----|---------------------|-----|-----|-----|---------------------------------------|------|---------------------------------------|------|-------------------------|
| Model | Insertion Loss (dB Max) | Return Loss (dB Min) | | | | Cross Talk (dB Min) | | | | Com. To Com. Rejection Ratio (dB Min) | | Diff. To Com. Mode Rejection (dB Min) | | Turns Ratio TX/RX (±5%) |
| | | 1~100 | 2~30 | 40 | 50 | 60~80 | 1 | 30 | 60 | 100 | 1~60 | 60~100 | 1~60 | |
| | MHz | MHz | | | | MHz | | | | MHz | | MHz | | 1 |
| LF8409 | -1.0 | -18 | -16 | -12.0 | -10 | -65 | -55 | -45 | -35 | -40 | -30 | -40 | -30 | 1.414:1 / 1:1 |
| LF8410 | -1.0 | -18 | -17 | -14.5 | -12 | -65 | -55 | -45 | -35 | -40 | -30 | -40 | -30 | 1:1 / 1:1 |
| LF8411 | -1.0 | -18 | -16 | -12.0 | -10 | -65 | -55 | -45 | -35 | -40 | -30 | -40 | -30 | 1.414:1 / 1:1 |
| LF8412 | -1.0 | -18 | -17 | -14.5 | -12 | -65 | -55 | -45 | -35 | -40 | -30 | -40 | -30 | 1:1 / 1:1 |

MECHANICAL CONSTRUCTION

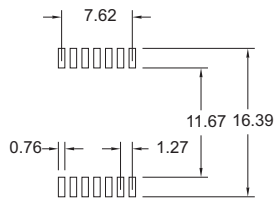
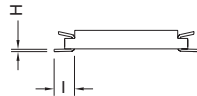
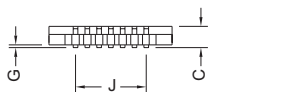
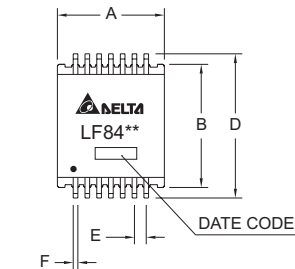

UNIT : mm / inch
 A = 11.53±0.254 / 0.454±0.010
 B = 13.27±0.254 / 0.522±0.010
 C = 2.40 / 0.094 MAX
 D = 15.44±0.254 / 0.608±0.010
 E = 1.27 / 0.050 (TYP)
 F = 0.50±0.127 / 0.020±0.005
 G = 0.254±0.127 / 0.010±0.005
 H = 0.254 / 0.010 (TYP)
 I = 2.05±0.254 / 0.081±0.010
 J = 7.62 / 0.3000 (TYP)

SCHEMATICS

LF8409

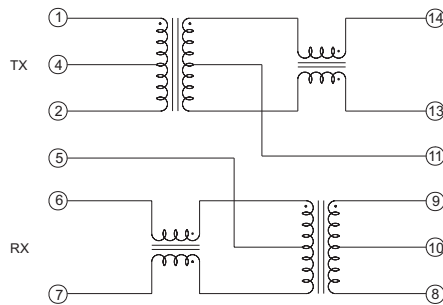

LF8410, LF8411, LF8412

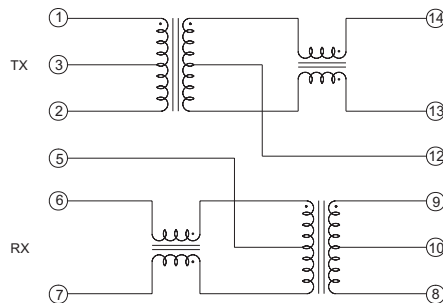

DELTA ELECTRONICS, INC.

(TAOYUAN PLANT CPBG) 252, SAN YING ROAD, KUEI SAN INDUSTRIAL ZONE, TAOYUAN SHIEN, TAIWAN, R.O.C.
 TEL: 886-3-3591968; FAX: 886-3-3591991
[Http://www.deltaww.com/products/networking](http://www.deltaww.com/products/networking)