

2N6686, 2N6687, 2N6688

File Number 1171

25-A *SwitchMax* Power Transistors

N-P-N Types for
Power Supplies and Other High-Voltage
Switching Applications

Features:

- High-temperature parameters guaranteed
- Fast switching speed
- Low $V_{CE}(sat)$
- Steel hermetic TO-204AA Package

TERMINAL DESIGNATIONS

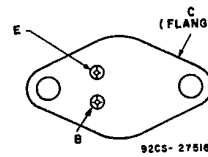

The RCA-2N6686, 2N6687, and 2N6688* SwitchMax series of silicon n-p-n power transistors feature high-voltage capability, fast switching speeds, and low saturation voltages, together with high safe-operating-area (SOA) ratings. They are specially designed for converters, inverters, pulse-width-modulated regulators and a variety of power switching circuits. These high-current, high-speed transistors are 100-per-cent tested for parameters that are essential to the design of high-power switching circuits. Switching times, including inductive turn-off time,

and saturation voltages are guaranteed at 125°C as well as at 25°C, to provide information necessary for worst-case design.

The 2N6686, 2N6687, and 2N6688 transistors are supplied in steel JEDEC TO-204AA hermetic packages.

*Formerly RCA Dev. Type Nos. TA9119A, TA9119B, TA9119C, respectively.

MAXIMUM RATINGS, Absolute-Maximum Values:

	2N6686	2N6687	2N6688	
* V_{CEV} $V_{BE} = -1.5V$	260	280	300	V
* $V_{CEX}(Clamped)$ $V_{BE} = -1.5V$	210	230	250	V
* V_{CEO}	160	180	200	V
* V_{EBO}		8		V
* $I_{C}(sat)$	25	25	20	A
* I_C	25	25	20	A
* I_{CM}		50		A
* I_B		8		A
* P_T TC up to 25°C		200		W
TC above 25°C, derate linearly		1.14		W/°C
* T_{stg}, T_J		-65 to 200		°C
* T_L At distance $\geq 1/16$ in. (1.58 mm) from seating plane for 10 s max.		235		°C

* In accordance with JEDEC registration data.

2N6686, 2N6687, 2N6688

ELECTRICAL CHARACTERISTICS $T_c = 25^\circ\text{C}$

CHARACTERISTIC	TEST CONDITIONS				LIMITS						UNITS
	VOLTAGE V dc		CURRENT A dc		2N6686		2N6687		2N6688		
	V_{CE}	V_{BE}	I_C	I_B	Min.	Max.	Min.	Max.	Min.	Max.	
I_{CEV}	260	-1.5	—	—	—	50	—	—	—	—	μA
	280	-1.5	—	—	—	—	—	50	—	—	
	300	-1.5	—	—	—	—	—	—	—	50	
I_{EBO}	—	-8	0	—	—	100	—	100	—	100	μA
$V_{CE0}(\text{sus})^b$	—	—	0.2 ^a	0	160	—	180	—	200	—	V
h_{FE}	2	—	1 ^a	—	30	—	30	—	25	—	—
	2	—	10 ^a	—	25	100	25	100	20	80	
	2	—	20 ^a	—	—	—	—	—	15	—	
	2	—	25 ^a	—	15	—	15	—	—	—	
$V_{BE}(\text{sat})$	—	—	20 ^a	2	—	—	—	—	—	1.8	V
	—	—	25 ^a	2.5	—	1.8	—	1.8	—	—	
$V_{CE}(\text{sat})$	—	—	20 ^a	2	—	—	—	—	—	1.5	V
	—	—	25 ^a	2.5	—	1.5	—	1.5	—	—	
V_{CEX}^b (Clamped $E_{B/B}$) $L = 25 \mu\text{H}$, $R_{BB} = 10 \Omega$	—	-4	25	3	210	—	230	—	250	—	
$I_{B/B}$	18	—	11.1	—	1	—	1	—	1	—	s
$ h_{re} $ $f = 5 \text{ MHz}$	10	—	1	—	4	20	4	20	4	20	—
f_T	10	—	1	—	20	100	20	100	20	100	MHz
C_{obo} $f = 0.1 \text{ MHz}$	10 ^c	—	—	—	300	650	300	650	300	650	pF
t_d^d	—	-4	20	2	—	—	—	—	—	0.1	μs
	—	-4	25	2.5	—	0.1	—	0.1	—	—	
t_r^d	—	-4	20	2	—	—	—	—	—	0.60	μs
	—	-4	25	2.5	—	0.60	—	0.60	—	—	
t_s^d	—	-4	20	2 ^e	—	—	—	—	—	1.50	μs
	—	-4	25	2.5 ^e	—	1.50	—	1.50	—	—	
t_f^d	—	-4	20	2 ^e	—	—	—	—	—	0.25	μs
	—	-4	25	2.5 ^e	—	0.25	—	0.25	—	—	
t_c $V_{CC} = 80 \text{ V}$, $L = 25 \mu\text{H}$, $R_C \leq 4 \Omega$, Collector clamped to V_{CEX}	—	-4	20	3 ^e	—	—	—	—	—	0.5	μs
	—	-4	25	3 ^e	—	0.5	—	0.5	—	—	

2N6686, 2N6687, 2N6688

ELECTRICAL CHARACTERISTICS (cont'd)

CHARACTERISTIC	TEST CONDITIONS				LIMITS					UNITS
	VOLTAGE V dc		CURRENT A dc		2N6686		2N6687		2N6688	
	V _{CE}	V _{BE}	I _C	I _B	Min.	Max.	Min.	Max.	Min.	

T_C = 125°C

* I _{CEV}	260 280 300	-1.5 -1.5 -1.5			-	0.5	-	0.5	-	-	mA
* V _{CE(sat)}			20 ^a 25 ^a	2 2.5	-	1.5	-	1.5	-	1.5	V
* t _r d		-4	20 25	2 2.5	-	0.8	-	0.8	-	0.8	μs
* t _s d		-4	20 25	2 2.5 ^e	-	2.5	-	2.5	-	2.5	
* t _{fd}		-4	20 25	2 2.5 ^e	-	0.8	-	0.8	-	0.8	
* t _c V _{CC} =80 V, L=25 μH, R _C ≤ 4 Ω, Collector Clamped to V _{CEX}		-4 -4	20 25	3 ^e 3 ^e	-	0.8	-	0.8	-	0.8	
* R _{θJC}	10		5		-	0.875	-	0.875	-	0.875	°C/W

* In accordance with JEDEC registration data.

^a Pulsed: pulse duration = 300 μs, duty factor ≤ 2%.

^b CAUTION: The sustaining voltage V_{CEO(sus)} and V_{CEX} MUST NOT be measured on a curve tracer.

^c V_{CB} value.

^d V_{CC} = 80 V, t_p = 20 μs

^e I_{B1} = -I_{B2}

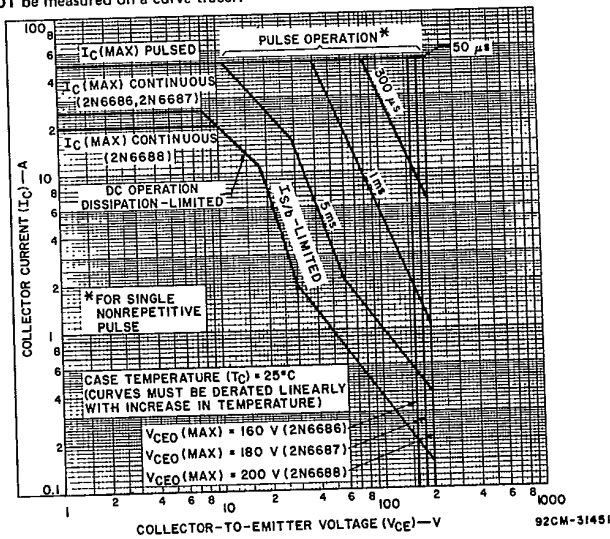

Fig. 1-Maximum operating areas for all types (T_C = 25°C).

2N6686, 2N6687, 2N6688

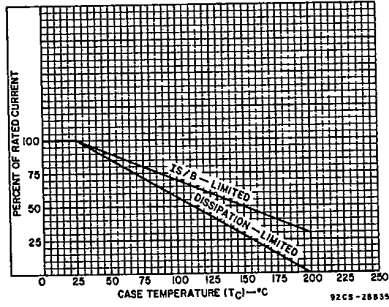

Fig. 2 - Dissipation and I_{SIB} derating curves for all types.

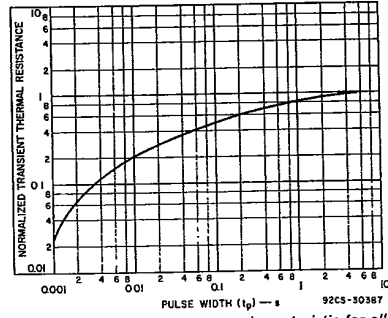

Fig. 3 - Typical thermal-response characteristic for all types.

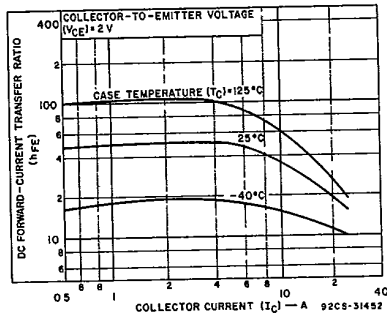

Fig. 4 - Typical dc beta characteristics for all types.

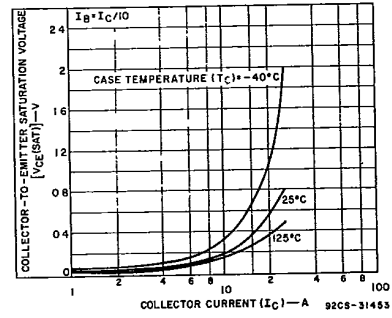

Fig. 5 - Typical collector-to-emitter saturation voltage characteristics for all types.

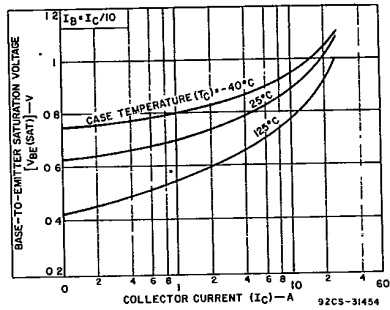

Fig. 6 - Typical base-to-emitter saturation voltage characteristic for all types.

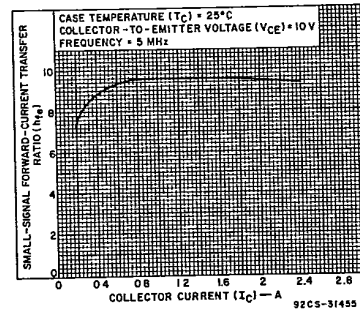

Fig. 7 - Typical small-signal forward-current transfer ratio characteristic for all types ($f = 5$ MHz).

2N6686, 2N6687, 2N6688

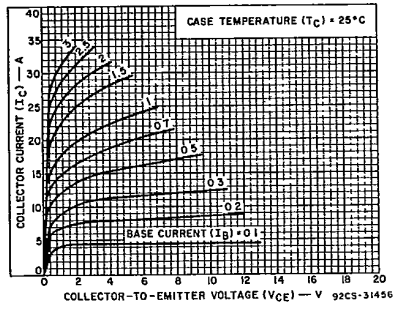

Fig. 8 — Typical output characteristics for all types.

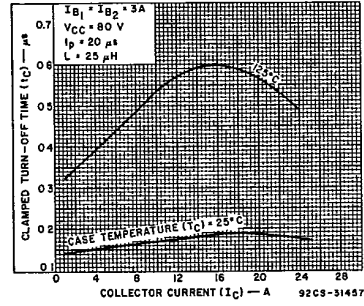

Fig. 9 — Typical clamped turn-off time characteristics for all types.

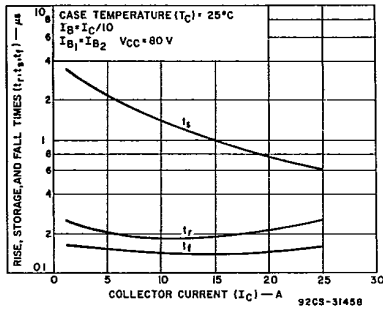

Fig. 10 — Typical saturated-switching-time characteristics as a function of collector current for all types.

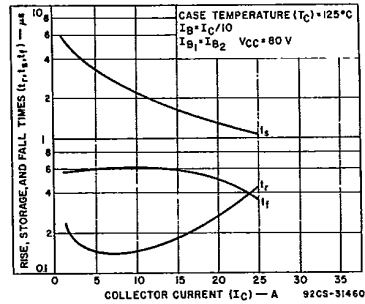

Fig. 11 — Typical saturated-switching-time characteristics at $T_c = 125^\circ\text{C}$ as a function of collector current for all types.

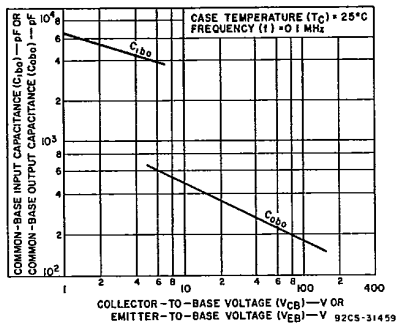

Fig. 12 — Typical common-base input (C_{ib}) or output (C_{ob}) capacitance characteristic for all types.

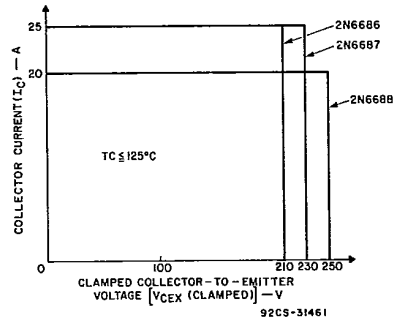

Fig. 13 — Maximum operating conditions for switching between saturation and cutoff for all types.

2N6686, 2N6687, 2N6688

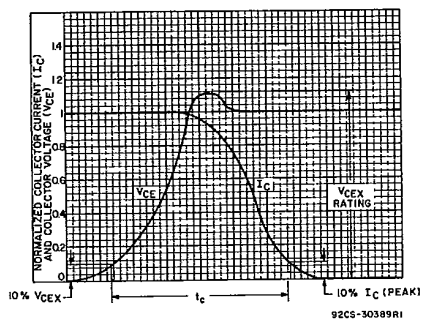

Fig. 14 — Oscilloscope display for normalized measurement of clamped inductive switching time (t_c).

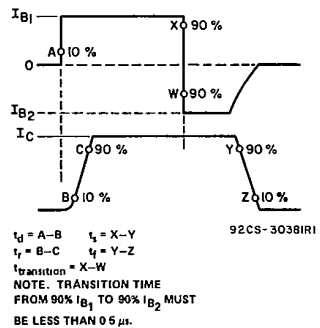

Fig. 15 — Phase relationship between input and output currents showing reference points for specification of switching times.

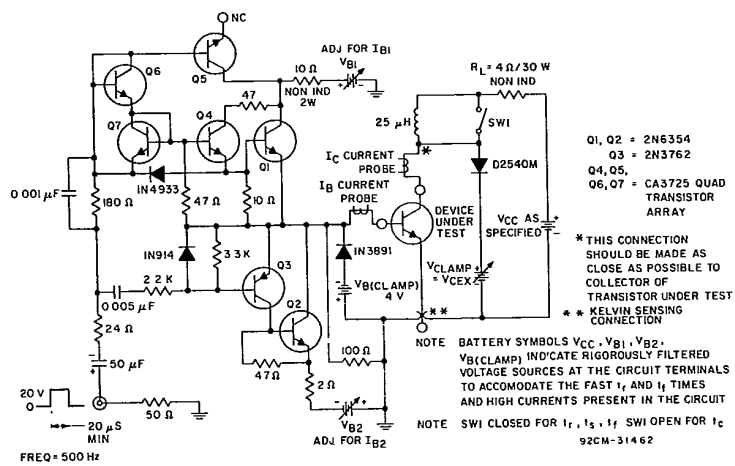

Fig. 16 — Circuit for measuring switching times.