

PRELIMINARY



Dual Output Mixed Voltage, DSM Models

Surface-Mount, 3.3V and 5V
15Watt, DC/DC Converters

Features

- Regulated 5V and 3.3V outputs
- 5V @ 2.65Amps/3.3V @ 3 Amps capability
- 15 Watts total output power
- Small 1" x 2" x 0.52" SMT package
- Available input voltage ranges:
10-18V, 18-36V or 36-75V
- No-load stable operation
- UL1950 and EN60950 safety approvals
-  mark available (75V-input models)
- Continuous short-circuit protection
- Fully isolated, 1500Vdc guaranteed
- -40 to +100°C operating temperature
- Input under and overvoltage shutdown
- Output OVP, thermal shutdown

For surface-mount applications requiring 15 Watts of power from 5V and 3.3V, DATEL offers a new power sharing DC/DC converter capable of meeting your output current requirements. The DSM-5/2.65-3.3/3-D48 (36-75V input), DSM-5/2.65-3.3/3-D24 (18-36V input) and DSM-5/2.65-3.3/3-D12 (10-18V input) are fully isolated DC/DC converters capable of delivering any combination of 5V and 3.3V output current up to a combined total of 15 Watts of output power.

Housed in a 1" x 2" x 0.52" metal, surface-mount package coated with electrically non-conductive finish, these converters are regulated by a 3.3V control loop that provides load regulation of $\pm 0.5\%$ for 3.3V output and $\pm 2\%$ for 5V output. All models include input Pi filtering, input overvoltage and undervoltage shutdown circuitry, output overvoltage protection, output short-circuit and current-limiting protection, and thermal shutdown. All models provide trim capability and an on/off control function or sync control. Fully synchronous output rectification provides high efficiency (86%) and a stable output under no-load conditions.

DSM power sharing modules offer low output ripple and noise performance, 1500 Vdc isolation voltage, and are fully specified for -40 to +100°C operation. These devices meet IEC950, UL1950 and EN6950 safety standards; CB reports are available on request. "D48" models are CE marked (meets LVD requirements).

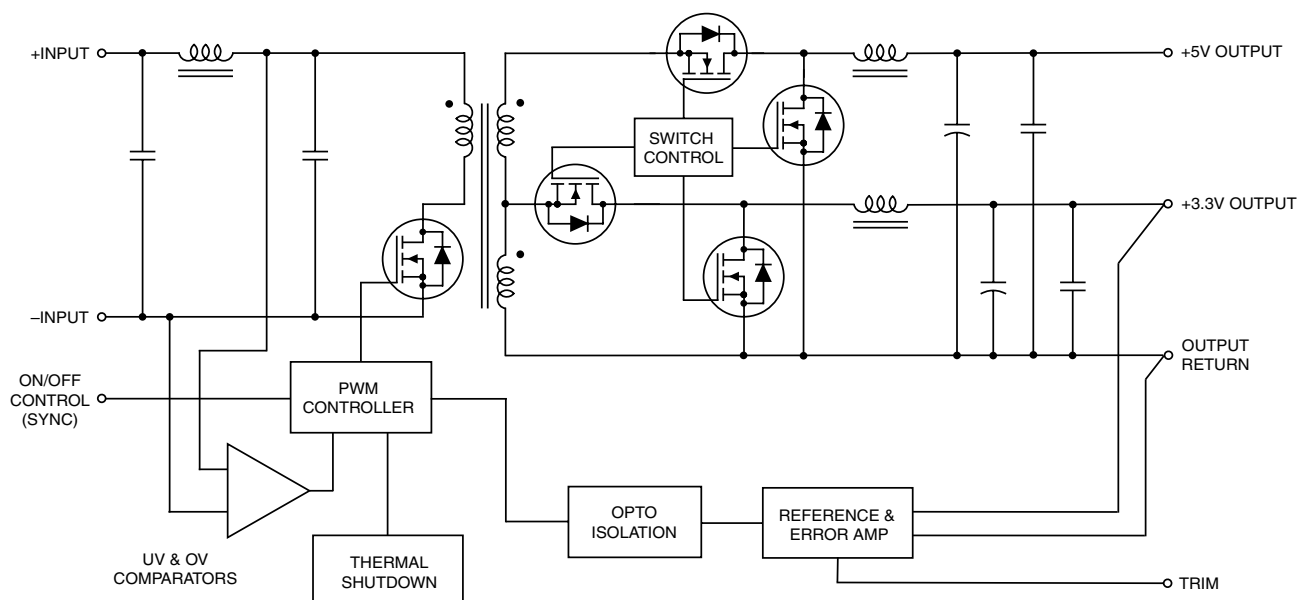

Figure 1. Simplified Schematic

Performance Specifications and Ordering Guide ^①

Model	Output						Input			Efficiency		Package (Case, Pinout)
	V _{OUT} (Volts)	I _{OUT} ^② (Amps)	R/N (mVp-p) ^③		Regulation (Max.)		V _{IN} Nom. (Volts)	Range (Volts)	I _{IN} ^⑤ (mA)	Min.	Typ.	
			Typ.	Max.	Line	Load ^④						
DSM-5/2.65-3.3/3-D12	5	2.65	40	75	±1%	±2%	12	10-18	70/1450	83%	86%	C18A, P36
	3.3	3	60	100	±0.5%	±0.5%						
DSM-5/2.65-3.3/3-D24	5	2.65	40	75	±1%	±2%	24	18-36	40/720	83%	86%	C18A, P36
	3.3	3	60	100	±0.5%	±0.5%						
DSM-5/2.65-3.3/3-D48	5	2.65	40	75	±1%	±2%	48	36-75	20/360	83%	86%	C18A, P36
	3.3	3	60	100	±0.5%	±0.5%						

① Typical at T_A = +25°C under nominal line voltage and balanced "full-load" conditions (5V @ 1.5A/3.3V @ 2.25A).
 ② Any combination of 5V/3.3V rated I_{OUT} current, not to exceed 15 Watts of output power. (See derating graphs).
 ③ Ripple/Noise (R/N) measured over a 20MHz bandwidth. All models are specified with 0.47µF ceramic in parallel with 100µF tantalum output capacitors.

④ Tested from 10% to 100% full load (other output at 10% full load).
 ⑤ Nominal line voltage, no load/balanced full-power condition.

PART NUMBER STRUCTURE

DSM - 5 / 2.65 - 3.3 / 3 - D48 S

Dual Output/
Surface-Mount Series

V₁ Nominal Output Voltage:
5 Volts

I₁ Maximum Output Current:
2.65 Amps

V₂ Nominal Output Voltage:
3.3 Volts

Add "S" suffix as desired

Input Voltage Range:
D12 = 10-18 Volts (12V nominal)
D24 = 18-36 Volts (24V nominal)
D48 = 36-75 Volts (48V nominal)
 I₂ Maximum Output Current:
3 Amps

Part Number Suffixes

DSM 15 Watt DC/DC's are designed so an On/Off Control function with either positive polarity (no suffix), or a Sync function ("S" suffix) can be added in the pin 3 position.

No Suffix On/Off Control function (positive polarity) on pin 3

S Sync function on pin 3

M E C A N I C A L S P E C I F I C A T I O N S

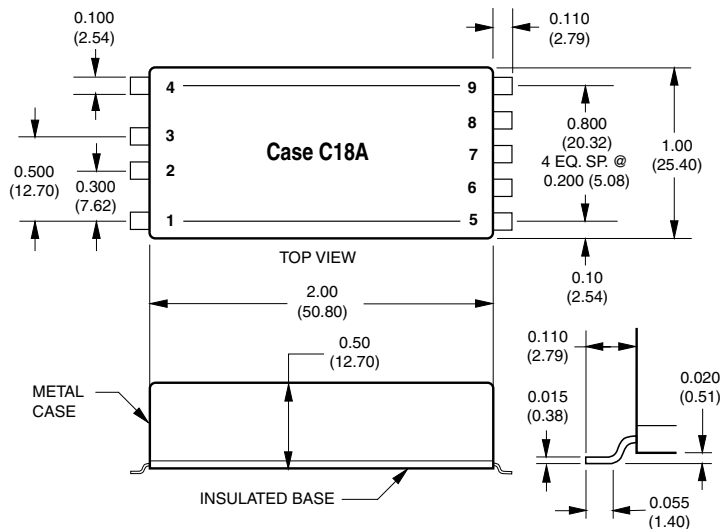

I/O Connections	
Pin	Function P36
1	+Input
2	-Input
3	On/Off Control
4	Case
5	+5V Output
6	NC
7	Output Output
8	+3.3V Output
9	Trim

Performance/Functional Specifications

Typical @ $T_A = +25^\circ\text{C}$ under nominal line voltage, balanced "full-load" conditions, unless noted. ①

Input	
Input Voltage Range:	
D12 Models	10-18 Volts (12V nominal)
D24 Models	18-36 Volts (24V nominal)
D48 Models	36-75 Volts (48V nominal)
Overvoltage Shutdown:	
D12 Models	19-23 Volts (21V nominal)
D24 Models	37-42 Volts (40V typical)
D48 Models	77-81 Volts (78.5V typical)
Start-Up Threshold:	
D12 Models	9-10 Volts (9.3V typical)
D24 Models	16.5-18 Volts (17V typical)
D48 Models	34-36 Volts (35V typical)
Undervoltage Shutdown:	
D12 Models	7.0-8.5 Volts (8V typical)
D24 Models	16-17 Volts (16.5V typical)
D48 Models	32.5-35.5 Volts (34.5V typical)
Input Current:	
Normal Operating Conditions	See Ordering Guide
Standby Mode:	
Off, OV, UV, Thermal Shutdown	10mA
Input Reflected Ripple Current:	
Source Impedance	<0.1 Ω , no external input filtering
D12 Models	TBD
D24/D48 Models	TBD
Internal Input Filter Type	Capacitive (1.5 μF)
Reverse-Polarity Protection:	
D12 Models	1 minute duration, 4A maximum
D24 Models	1 minute duration, 2A maximum
D48 Models	1 minute duration, 1A maximum
On/Off Control: (Pin 3): ③ ④ ⑥	On = open or 13V - +V _{IN} , I _{IN} @ 13V = 800 μA Off = 0-0.8V, I _{IN} @ 0V = 1mA
Sync: (Option, Pin 4): ③ ④	
Input Threshold (Rising Edge Active)	1-2.7 Volts
Input Voltage Low	0-0.9 Volts
Input Voltage High	2.8-5 Volts
Input Resistance	35k Ω minimum
Output High Voltage (100 μA load)	3.5-4.8 Volts
Output Drive Current	35mA
Input/Output Pulse Width	160-360nsec
Output	
V_{OUT} Accuracy:	
5V Output	$\pm 2\%$ maximum
3.3V Output	$\pm 1.5\%$ maximum
Minimum Loading Per Specification	250mA
Minimum Load For Stability	No load
Ripple/Noise (20MHz BW) ⑤	See Ordering Guide
Line/Load Regulation	See Ordering Guide
Efficiency	See Ordering Guide / Efficiency Curves
Cross Regulation:	
5V Output (5V @ 0.25A, 3.3V @ 0.25-3A)	TBD
3.3V Output (3.3V @ 0.25A, 5V @ 0.25-2.65A)	TBD
Trim Range ②	$\pm 5\%$
Isolation Voltage:	
Input-to-Output	1500Vdc minimum
Input-to-Case	TBD Vdc minimum
Output-to-Case	TBD Vdc minimum

Output (continued)	
Isolation Capacitance	470pF
Isolation Resistance	100M Ω
Current Limit Inception:	
5V @ 95% V _{OUT} (3.3V @ 0.25A)	4-5.5 Amps
3.3V @ 98.5% V _{OUT} (5V @ 0.25A)	3-4 Amps
Short Circuit Current:	
5V Output	5.5 Amps average, continuous current
3.3V Output	3 Amps average, continuous current
Overvoltage Protection:	Magnetic feedback
5V Output	TBD Volts
3.3V Output	TBD Volts
Maximum Capacitive Loading:	
D12 Models	TBD μF (5V) TBD μF (3.3V)
D24 Models	TBD μF (5V) TBD μF (3.3V)
D48 Models	TBD μF (5V) TBD μF (3.3V)
Temperature Coefficient	$\pm 0.02\%$ per $^\circ\text{C}$
Dynamic Characteristics	
Dynamic Load Response: ②	
5V (50-100% step to 97.5% V _{OUT})	300 μsec maximum (3.3V @ 0.25A)
3.3V (50-100% step to 98.5% V _{OUT})	300 μsec maximum (5V @ 0.25A)
Start-Up Time:	
V _{IN} to V _{OUT}	10msec maximum
On/Off to V _{OUT}	TBD msec maximum
Switching Frequency	250kHz ($\pm 25\text{kHz}$)
Environmental	
MTBF: ⑦	
D12 Models	TBD hours
D24 Models	TBD hours
D48 Models	TBD hours
Operating Temperature: (Ambient): ②	
Without Derating:	+60 $^\circ\text{C}$
With Derating	To +100 $^\circ\text{C}$ (See Derating Curves)
Case Temperature:	
Maximum Operational	+100 $^\circ\text{C}$
For Thermal Shutdown	TBD $^\circ\text{C}$ minimum, TBD $^\circ\text{C}$ maximum
Storage Temperature	-40 to +120 $^\circ\text{C}$
Physical	
Dimensions	2" x 1" x 0.52" (50.8 x 25.4 x 13.2mm)
Internal Case Connection	Case connection via pin 4
Case Material	Corrosion resistant steel with non-conductive, epoxy-based, black enamel finish and plastic baseplate
Pin Material	Brass, solder coated, surface-mount leads
Weight TBD ounces	1.4 ounces (39.7 grams)
Primary to Secondary Insulation Level	Operational

① Balanced "full-load" is 5V @ 1.5A/3.3V @ 2.25A. All models are specified with external 0.47 μF ceramic and 100 μF tantalum output capacitors.

② See Technical Notes/Graphs for details.

③ The On/Off Control function can be replaced with a Sync function. See Part Number Suffixes and Technical Notes for details.

④ Applying a voltage to On/Off Control (pin 3) when no input power is applied to the converter can cause permanent damage.

⑤ Output noise may be further reduced with the installation of additional external output capacitors. See Technical Notes.

⑥ On/Off control is designed to be driven with open collector or by appropriate voltage levels. Voltages must be referenced to the -Input (Pin 2).

⑦ Demonstrated MTBF available on request.

⑧ For conditions with less than minimum loading, outputs remain stable. However, regulation performance will degrade.

Absolute Maximum Ratings

Input Voltage:		
Continuous:	D12 Models	23 Volts
	D24 Models	42 Volts
	D48 Models	81 Volts
Transient (100msec):	D12 Models	25 Volts
	D24 Models	50 Volts
	D48 Models	100 Volts
Input Reverse-Polarity Protection: ② Input Current must be limited. 1 minute duration. Fusing recommended.		
	D12 Models	4 Amps
	D24 Models	2 Amps
	D48 Models	2 Amps
Output Current ② Current limited. Devices can withstand an indefinite output short circuit.		
On/Off Control (Pin 3) Max. Voltages:		
Referenced to -Input (pin 2)		
	No Suffix	+VIN
	S Suffix	+5.7 Volts
Storage Temperature -40 to +120°C		
Lead Temperature (Soldering, 10 sec.) +300°C		

These are stress ratings. Exposure of devices to any of these conditions may adversely affect long-term reliability. Proper operation under conditions other than those listed in the Performance/Functional Specifications Table is not implied, nor recommended.

TECHNICAL NOTES

Trimming Output Voltages

The DSM converters have a trim capability (Pin 9) that allow users to adjust the output voltages ±5%. A trim adjustment will cause an equal percentage of change in both outputs. Adjustments to the output voltages can be accomplished via a trim pot, Figure 2, or a single fixed resistor as shown in Figures 3 and 4. A single fixed resistor can increase or decrease the output voltage depending on its connection. Fixed resistors should have absolute TCR's less than 100ppm/°C to minimize sensitivity to changes in temperature.

A single resistor connected from the Trim pin (Pin 9) to the +3.3V Output (Pin 8), see Figure 3, will decrease the output voltages. A resistor connected from the Trim pin (Pin 9) to Output Return (Pin 7) will increase the output voltages.

Trim adjustments greater than 5% can have an adverse effect on the converter's performance and is not recommended.

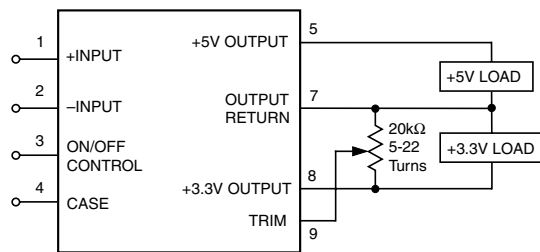
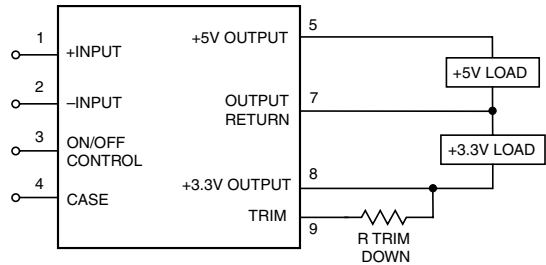

Figure 2. Trim Connections Using A Trimpot



$$R_{T_{DOWN}} (k\Omega) = \frac{2.49(V_O - 1.234)}{3.3 - V_O} - 16.9$$

Figure 3. Decrease Output Voltage Trim Connections Using A Fixed Resistor

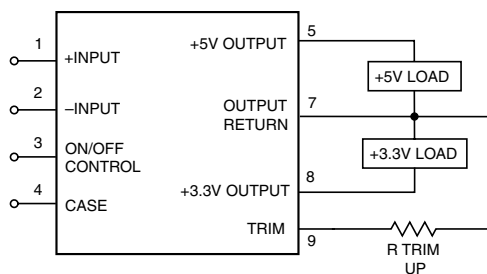
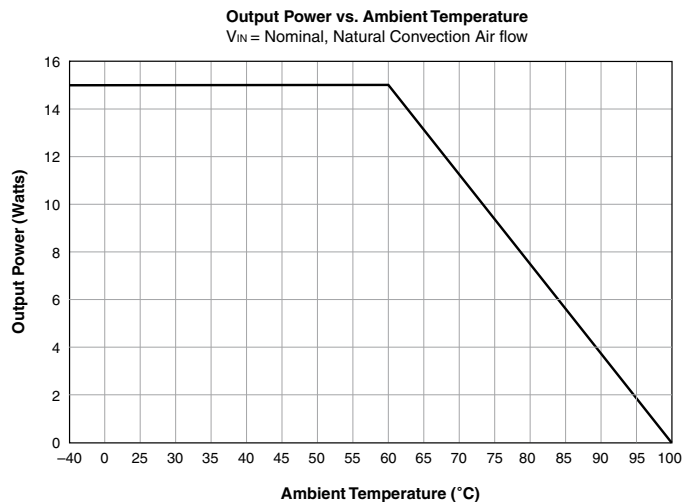

Figure 4. Increase Output Voltage Trim Connections Using A Fixed Resistor

$$R_{T_{UP}} (k\Omega) = \frac{3.073}{V_O - 3.3} - 16.9$$

Accuracy of adjustment is subject to tolerances or resistor values and factory-adjusted output accuracy.
 V_O = desired output voltage.



Typical Performance Curves

D12 Models

DSM-5/2.65-3.3/3-D12 - Typical 3.3V V_{OUT} Efficiency vs. Load (+5V @ 250mA)

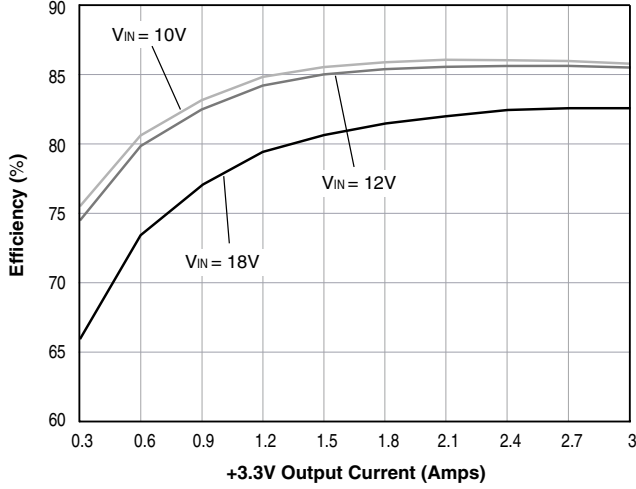

DSM-5/2.65-3.3/3-D12 - Typical 5V V_{OUT} Efficiency vs. Load (+3.3V @ 250mA)

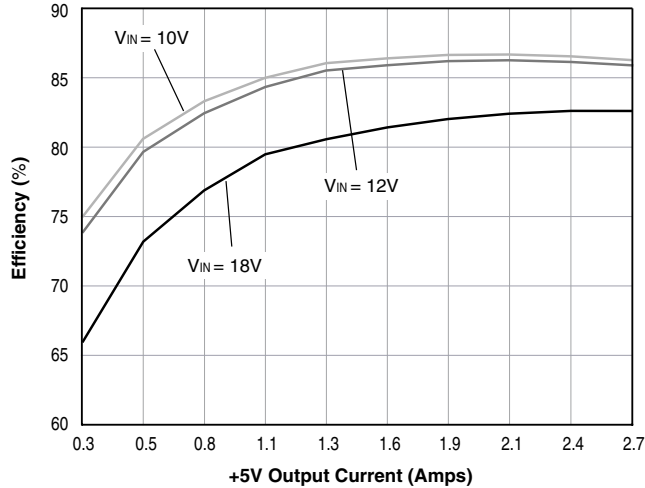

DSM-5/2.65-3.3/3-D12 - Efficiency vs. Line and Load

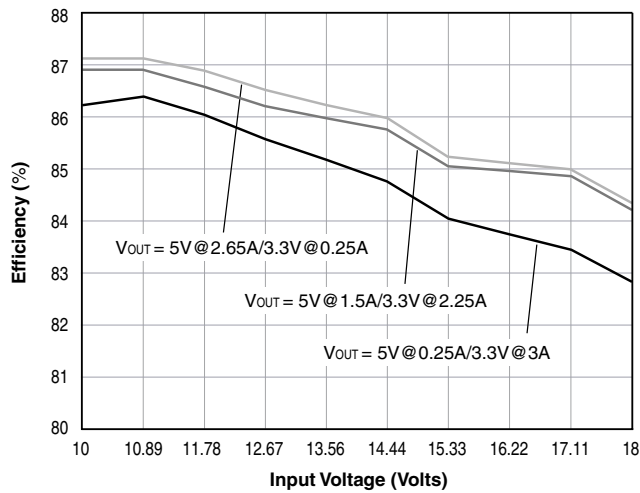

D24 Models

DSM-5/2.65-3.3/3-D24 - Typical 3.3V V_{OUT} Efficiency vs. Load (+5V @ 250mA)

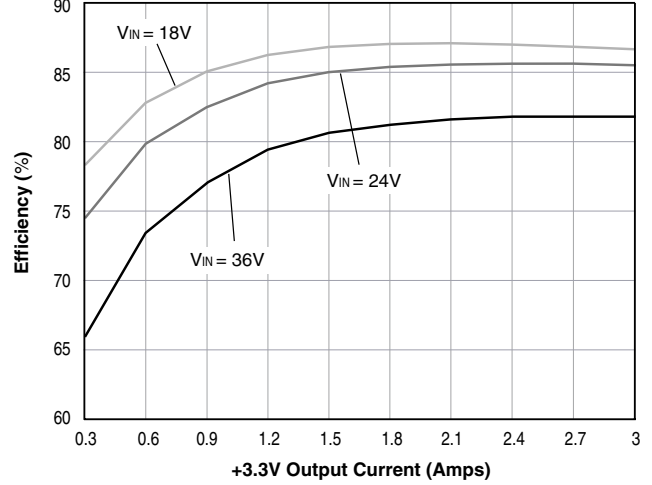

DSM-5/2.65-3.3/3-D24 - Typical 5V V_{OUT} Efficiency vs. Load (+3.3V @ 250mA)

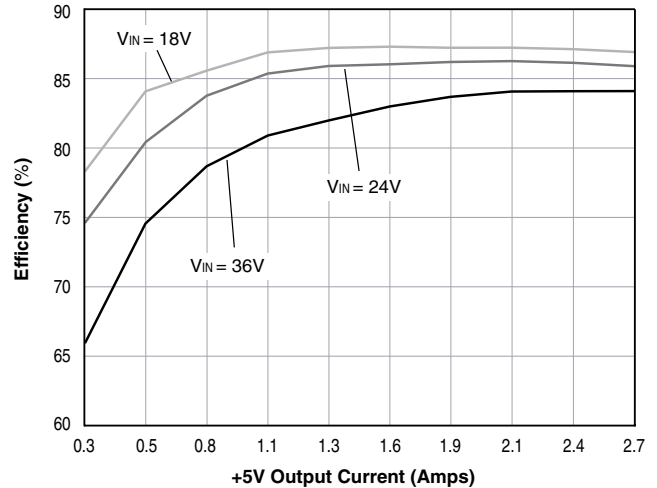

DSM-5/2.65-3.3/3-D24 - Efficiency vs. Line and Load

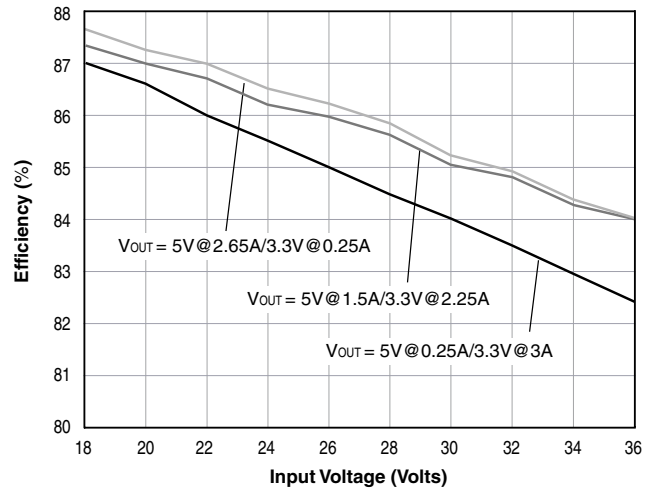

Typical Performance Curves

D48 Models

DSM-5/2.65-3.3/3-D48 - Typical 3.3V_{OUT} Efficiency vs. Load
(+5V @ 250mA)

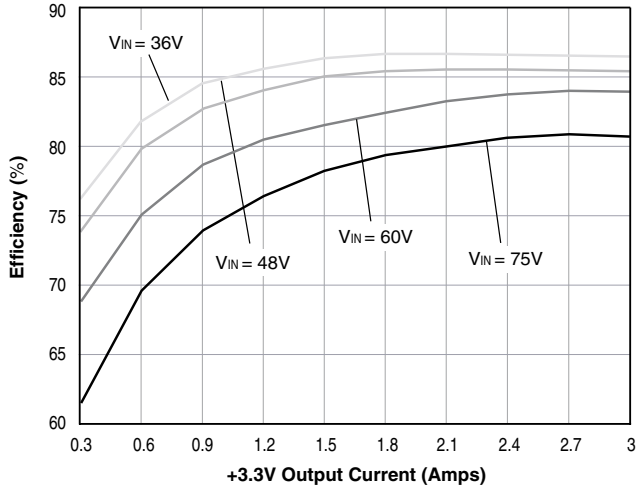

DSM-5/2.65-3.3/3-D48 - Typical 5V_{OUT} Efficiency vs. Load
(+3.3V @ 250mA)

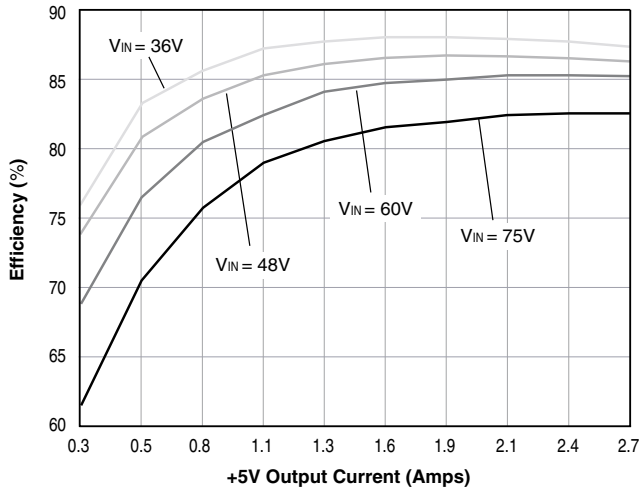

DSM-5/2.65-3.3/3-D48 - Efficiency vs. Line and Load

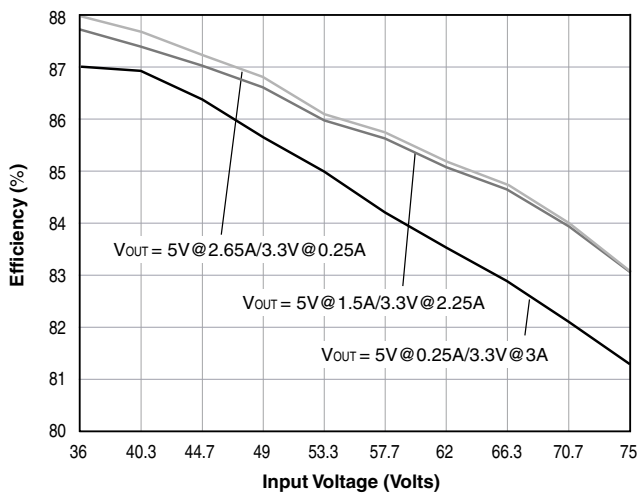

D12, 24, 48 Models

Start-Up from V_{IN}

(V_{IN} = nominal, 5V @ 1.5A/3.3V @ 2.25A, 0.47μF || 100μF tantalum output capacitors.)

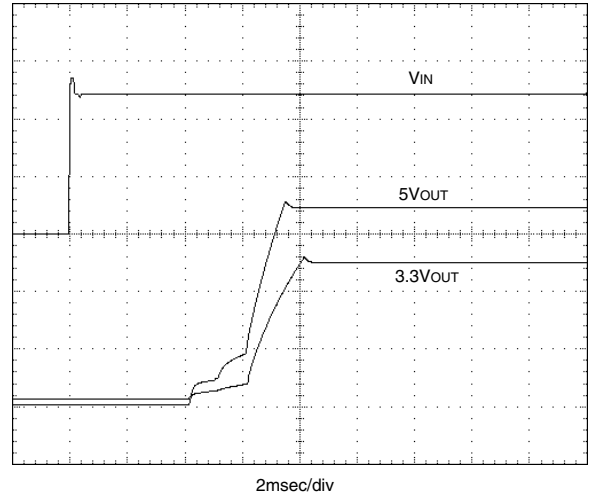



ISO 9001 REGISTERED

DS-0491 1/01

DATEL, Inc. 11 Cabot Boulevard, Mansfield, MA 02048-1151
Tel: (508) 339-3000 (800) 233-2765 Fax: (508) 339-6356
Internet: www.datel.com Email: sales@datel.com

DATEL (UK) LTD. Tadley, England Tel: (01256)-880444
DATEL S.A.R.L. Montigny Le Bretonneux, France Tel: 01-34-60-01-01
DATEL GmbH München, Germany Tel: 89-544334-0
DATEL KK Tokyo, Japan Tel: 3-3779-1031, Osaka Tel: 6-6354-2025

DATEL makes no representation that the use of its products in the circuits described herein, or the use of other technical information contained herein, will not infringe upon existing or future patent rights. The descriptions contained herein do not imply the granting of licenses to make, use, or sell equipment constructed in accordance therewith. Specifications are subject to change without notice. The DATEL logo is a registered DATEL, Inc. trademark.