

66173

**GULL WING HERMETICALLY SEALED
DUAL CHANNEL OPTOCOUPLER
(Electrically Similar To 6N134)**

Mii
OPTOELECTRONIC
PRODUCTS
DIVISION

Rev. B 4/29/03

Features:

- 5 MHz bandwidth typical
- 1000 Vdc isolation test voltage
- TTL compatible input and output
- High radiation immunity
- Faraday shield to provide high common mode rejection

Applications:

- Military and Space
- High reliability systems
- Voltage Level Shifting
- Isolated Receiver Input
- Communication systems
- Medical systems

DESCRIPTION

The **66173** dual channel optocoupler consists of two LEDs optically coupled to two high speed, high gain inverting detector gates. Maximum isolation can be achieved while providing TTL outputs capable of switching with propagation delays of 65ns typical. The 66173 is a 10 pin gull wing hermetically sealed package and is available in standard and screened versions or tested to customer specifications.

ABSOLUTE MAXIMUM RATINGS

Storage Temperature.....	-65°C to +150°C
Operating Free-Air Temperature Range	-55°C to +125°C
Lead Solder Temperature (10s, 1/16" [1.6mm] from package)	260°C
Peak Forward Input Current (each channel)	40mA (1ms duration)
Average Forward Input Current (each channel).....	20mA
Input Power Dissipation (each channel).....	35mW
Reverse Input Voltage (each channel).....	5V
Supply Voltage.....	7V (1-minute maximum)
Output Current - I _O (each channel)	25mA
Output Power Dissipation (each channel).....	40mW
Output Voltage - V _O (each channel).....	7V
Total Power Dissipation (both channels).....	350mW

Package Dimensions

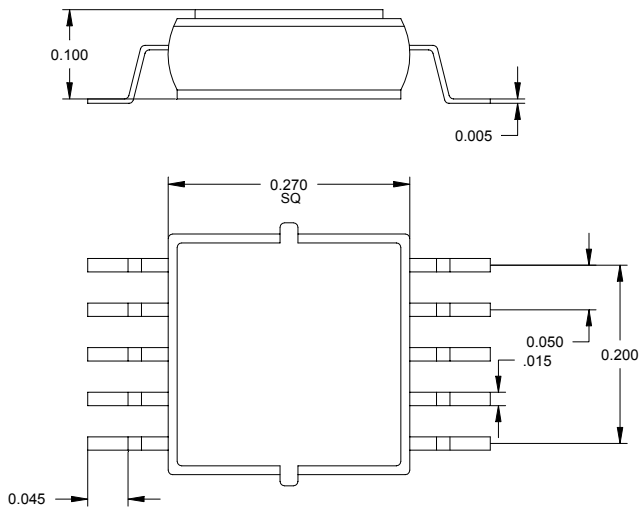

DIMENSIONS ARE IN INCHES

Schematic Diagram

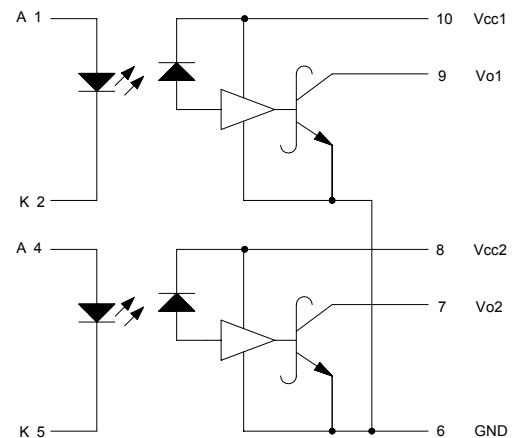

NOTE: A .01 TO 0.1 μF BYPASS CAPACITOR
MUST BE CONNECTED BETWEEN
PINS 6 AND 10

ELECTRICAL CHARACTERISTICS

 $T_A = -55^{\circ}\text{C}$ TO AT 125°C UNLESS OTHERWISE SPECIFIED.

Rev B 4/29/03

PARAMETER	SYMBOL	MIN	TYP	MAX	UNITS	TEST CONDITIONS	NOTE
High Level Output Current	I_{OH}		5	250	μA	$V_{CC} = 5.5\text{V}$, $V_O = 5.5\text{V}$, $I_F = 250\mu\text{A}$	1, 9
Low Level Output Voltage	V_{OL}		0.35	0.6	V	$V_{CC} = 5.5\text{V}$, $I_F = 10\text{mA}$ I_{OL} (Sinking) = 10mA	1
High Level Supply Current	I_{CCH}		18	28	mA	$V_{CC} = 5.5\text{V}$, $I_F = 0$ (Both Channels)	
Low Level Supply Current	I_{CCL}		26	36	mA	$V_{CC} = 5.5\text{V}$, $I_F = 20\text{mA}$ (Both Channels)	
Input Forward Voltage	V_F		1.5	1.75	v	$I_F = 20\text{mA}$	1
Input Reverse Breakdown Voltage	BV_R	5			v	$I_R = 10\mu\text{A}$	
Input-Output Insulation Leakage Current	I_{I-O}			1.0	μA	$V_{I-O} = 1000\text{Vdc}$, Relative Humidity = 45% $T_a = 25^{\circ}\text{C}$, $t = 5\text{s}$	2
Propagation Delay Time To High Output Level	t_{PLH}		65	100	ns	$R_L = 510\Omega$, $C_L = 15\text{pF}$ $I_F = 13\text{mA}$, $T_a = 25^{\circ}\text{C}$	5
Propagation Delay Time To Low Output Level	t_{PHL}		55	100	ns	$R_L = 510\Omega$, $C_L = 15\text{pF}$ $I_F = 13\text{mA}$, $T_a = 25^{\circ}\text{C}$	6

TYPICAL CHARACTERISTICS $T_A = 25^{\circ}\text{C}$, $V_{CC} = 5\text{V}$ EACH CHANNEL

PARAMETER	SYMBOL	MIN	TYP	UNITS	TEST CONDITIONS	NOTE
Input Capacitance	C_{IN}		60	pF	$V_F = 0$, $f = 1\text{MHz}$	1
Input Diode Temperature Coefficient	$\frac{\Delta V_F}{\Delta T_A}$		-1.9	mV/ $^{\circ}\text{C}$	$I_F = 20\text{mA}$	1
Resistance (Input-Output)	R_{I-O}		10^{12}	Ω	$V_{I-O} = 500\text{V}$	3
Capacitance (Input-Output)	C_{I-O}		1.7	pF	$f = 1\text{MHz}$	3
Input-Input Insulation Leakage Current	I_{I-I}		0.5	nA	Relative Humidity = 45% $V_{I-I} = 500\text{V}$, $t = 5\text{s}$	4
Resistance (Input-Input)	R_{I-I}		10^{12}	Ω	$V_{I-I} = 500\text{V}$	4
Capacitance (Input-Input)	C_{I-I}		0.80	pF	$f = 1\text{MHz}$	4
Output Rise-Fall Time (10-90%)	t_r , t_f		35	ns	$R_L = 510\Omega$, $C_L = 15\text{pF}$ $I_F = 13\text{mA}$	
Common Mode Transient Immunity at High Output Level	CM_H	1000	10000	V/ μs	$V_{CM} = 10\text{V}$ (peak), V_O (min) = 2V, $R_L = 510\Omega$, $I_F = 0\text{mA}$	7
Common Mode Transient Immunity at Low Output Level	CM_L	1000	10000	V/ μs	$V_{CM} = 10\text{V}$ (peak), V_O (max) = 0.8V, $R_L = 510\Omega$, $I_F = 10\text{mA}$	8

NOTES:

- Each channel
- Measured between pins 1 through 5 shorted together and pins 6 through 10 shorted together.
- Measured between pins 1 and 2 or 4 and 5 shorted together, and pins 6 through 10 shorted together.
- Measured between pins 1 and 2 shorted together, and pins 4 and 5 shorted together.
- The t_{plh} propagation delay is measured from the 6.5mA point on the trailing edge of the input pulse to the 1.5V point on the trailing edge of the output pulse.
- The t_{phl} propagation delay is measured from the 6.5mA point on the leading edge of the input pulse to the 1.5V point on the leading edge of the output pulse.
- CM_H is the max. tolerable common mode transient to assure that the output will remain in a high logic state (i.e. $V_o > 2.0\text{V}$).
- CM_L is the max. tolerable common mode transient to assure that the output will remain in a low logic state (i.e. $V_o < 0.8\text{V}$).
- It is essential that a bypass capacitor (.01 to 0.1 μF ceramic) be connected from pin 6 to pin 10.

RECOMMENDED OPERATING CONDITIONS

PARAMETER	SYMBOL	MIN	MAX	UNITS
Input Current, Low Level Each Channel	I_{FL}	0	100	μA
Input Current, High Level Each Channel	I_{FH}	12.5	20	mA
Supply Voltage	V_C	4.5	5.5	V
Fan Out (TTL Load) Each Channel	N		6	
Operating Temperature	T_A	-55	125	$^{\circ}\text{C}$

SELECTION GUIDE

PART NUMBER	PART DESCRIPTION
66173-000	Dual Channel optocoupler, full mil-temp (-55° to +125°C) with 100% device screening
66173-002	Dual Channel optocoupler, military operating range (-55° to +125°C)
66173-003	Dual Channel optocoupler, commercial (0° to 70°C)
66173-004	Dual Channel optocoupler, extended temperature range (-40° to +85°C)
66173-01X	Dual Channel optocoupler, hot solder dipped leads, full mil-temp (-55 to +125°C), 100% screening