

DESCRIPTION

The MSC-LX1801 is the IC1 "Spark" for the MED427A-1 module. The "Spark" chip has an oscillator, a voltage doubler, and a level shifter. The oscillator is a "555" timer variant where the external resistor (Rref) determines the frequency. The voltage doubler increases the output (OUT) of the oscillator by a factor of 2 (times VDDLO). The voltage doubler also provides a single output voltage if disabled (EN2x). This level shifter shifts voltage inputs from the lower voltage (VDDlo) to the higher voltage (VDDhi).

IMPORTANT: For the most current data, consult MICROSEMI's website: <http://www.microsemi.com>

KEY FEATURES

- Low peak current consumption: <2mA
- 3V operation
- Small form factor: 1.45mm²
- Double/single output voltage option
- Solder bumped die

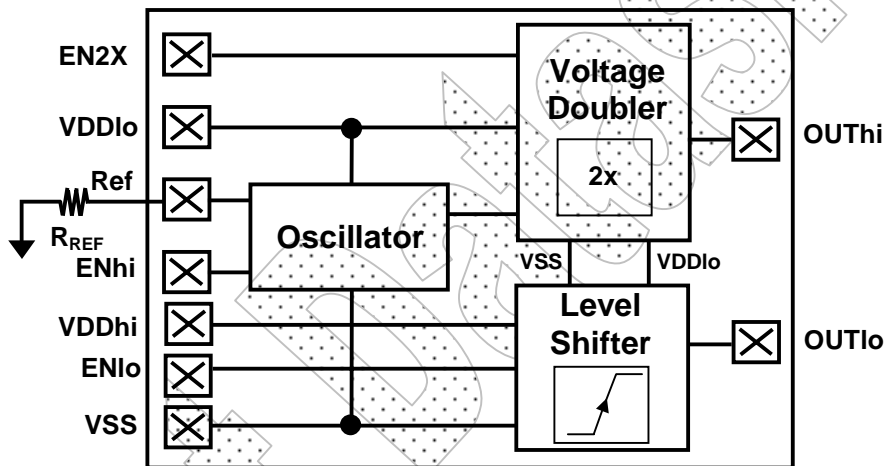
BLOCK DIAGRAM

Simplified Block Diagram

PACKAGE ORDER INFO

T _J (°C)	Package Number
10 to 55	LX1801



CARLSBAD DIVISION

LX1801

"SPARK" for MED427A-1

TARGET DATASHEET

ABSOLUTE MAXIMUM RATINGS

Input Upper Supply Voltage (VDDhi)..... 0.0V to +20.0V
 Input Lower Supply Voltage (VDDlo) 0.0V to +4.0V
 ESD Voltage..... 2kV
 Storage Temperature Range(T_{STOR}).....0°C to 55°C
 Storage humidity..... 10% to 90%

Note: Exceeding these ratings could cause damage to the device. All voltages are with respect to Ground. Currents are positive into, negative out of specified terminal.

PACKAGE PIN OUT

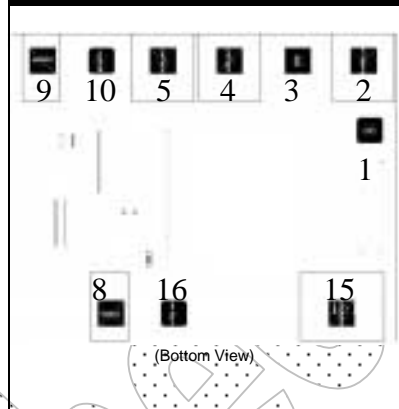

FUNCTIONAL PIN DESCRIPTION

PIN NAME	PIN No 16 PIN DIP	DESCRIPTION
OUT	1	2x AC output to close IGBT switch
1X_OUT	15	1x AC output to close IGBT switch
OUT_LO	16	DC output to close IGBT switch
VDDLO	8	Lower supply voltage
VSS	9	Ground
VDDHI	10	Higher supply voltage
EN_LO	5	Enable lower IGBT input
EN_HI	4	Enable upper IGBT input
RREF	3	Reference resistor for oscillator frequency
EN2X	2	Enable 2x out (When disabled, 1x out)

EXTERNAL COMPONENTS

Symbol	Value	Tolerance	Function
R _{REF}	33kΩ	5%	Determines oscillator frequency



CARLSBAD DIVISION

LX1801

"SPARK" for MED427A-1

TARGET DATASHEET

OPERATING CONDITIONS

Parameter	Symbol	Min	Typ	Max	Unit
Higher supply voltage	VDDhi	15	16	20	V
Lower supply voltage	VDDlo	2.6	3.0	3.4	V
Operating temperature	T _{AMB}	31	37	43	°C

ELECTRICAL CHARACTERISTICS

Unless otherwise specified, the following specifications apply over the operating ambient temperature T_A=37°C except where otherwise noted. Test conditions: VDDHI=16V, EN2X=VDDLO=3.0V, VSS=0V, VDDHI impedance=2kOhm, OUTHi load=5pF, OUTlo load=3nF

Parameter	Symbol	Test Conditions	LX1801			Units
			Min	Typ	Max	
Average operating current	IDD _{avg,hi}	-ENhi & Enlo=VDDlo -Measure from VDDhi -no load			100	µA
Oscillator operating current	IDD _{osc}	-ENhi=VDDlo -ENlo=VSS -Measure from VDDlo -no load			3	mA
Standby operating current	IDD _{Stdby}	-ENhi & Enlo=VSS -Measure from VSS -no load			1	nA
Frequency output	f	-ENhi=VDDlo -ENlo=VSS -no load			10	MHz
Voltage drop limit for OUTHi -max VSS+V _{lim,hi} -min VDDhi-V _{lim,hi}	V _{lim,hi}	-ENhi & Enlo=VDDlo			1	V
Voltage drop limit for OUTlo -max VSS+V _{lim,hi} -min VDDhi-V _{lim,hi}	V _{lim,lo}	-ENhi & Enlo=VDDlo			1	V
Rise time for OUTHi	t _{rise,hi}	-10%-90%*VDDhi			10	µs
Rise time for OUTlo	t _{rise,lo}	-10%-90%*VDDhi			10	µs
Fall time for OUTHi	t _{fall,hi}	-90%-10%*VDDhi			10	µs
Fall time for OUTlo	t _{fall,lo}	-90%-10%*VDDhi			10	µs
Enable time for OUTHi	t _{en,hi}	-Measure ENhi=90%*VDDlo to OUTHi=90%*VDDhi			10	µs
Enable time for OUTlo	t _{en,lo}	-Measure ENlo=90%*VDDlo to OUTlo=90%*VDDhi			10	µs
Disable time for OUTHi	t _{dis,hi}	-Measure ENhi=10%*VDDlo to OUTHi=10%*VDDhi			300	µs
Disable time for OUTlo	t _{dis,lo}	-Measure ENlo=10%*VDDlo to OUTlo=10%*VDDhi			300	µs
Average operating current	IDD _{avg,hi}	-ENhi & Enlo=VDDlo -Measure from VDDhi -no load			100	µA



CARLSBAD DIVISION

LX1801

"SPARK" for MED427A-1

TARGET DATASHEET

MECHANICALS

10-Pin Bare Die

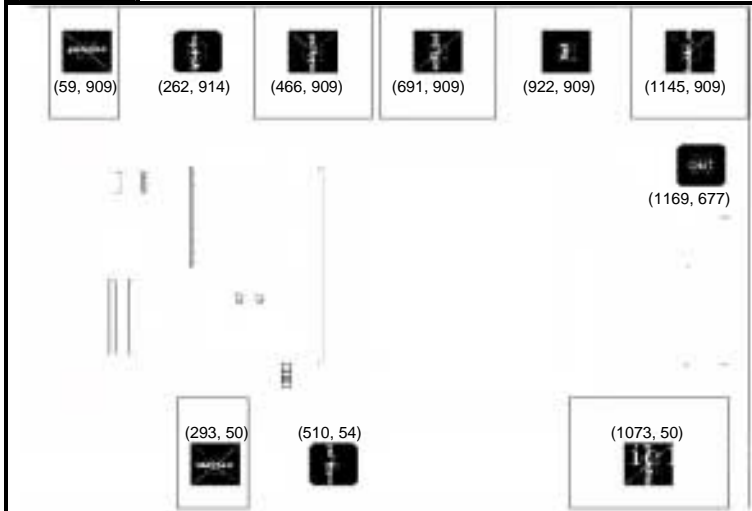

(0,0)

Pad Locations are (Xmin, Ymin) and are in um

Dim	MILLIMETERS		INCHES	
	MIN	MAX	MIN	MAX
X		1.40		0.055
Y		1.14		0.045

Note:

1. Dimensions do not include mold flash or protrusions; these shall not exceed 0.155mm(.006") on any side. Lead dimension shall not include solder coverage.

www.Microsemi.com

MECHANICALS