

128 Segment LCD Drivers

CMOS

The MC14LC5003/5004 are 128-segment, multiplexed-by-four LCD Drivers. The two devices are functionally the same except for their data input protocols. The MC14LC5003 uses a serial interface data input protocol. The device may be interfaced to the MC68HCXX product families using a minimal amount of software (see example). The MC14LC5004 has a IIC interface and has essentially the same protocol, except that the device sends an acknowledge bit back to the transmitter after each eight-bit byte is received. MC14LC5004 also has a "read mode", whereby data sent to the device may be retrieved via the IIC bus.

The MC14LC5003/MC14LC5004 drives the liquid-crystal displays in a multiplexed-by-four configuration. The device accepts data from a microprocessor or other serial data source to drive one segment per bit. The chip does not have a decoder, allowing for the flexibility of formatting the segment data externally.

Devices are independently addressable via a two-wire (or three-wire) communication link which can be common with other peripheral devices.

The MC14LC5003/MC14LC5004 are low cost version of MC145003 and MC145004 without cascading function.

- Drives 128 Segments Per Package
- May Be Used with the Following LCDs: Segmented Alphanumeric, Bar Graph, Dot Matrix, Custom
- Quiescent Supply Current: 30 μ A @ 2.7 V V_{DD}
- Operating Voltage Range: 2.7 to 5.5 V
- Operating Temperature Range: -40 to 85C
- Separate Access to LCD Drive Section's Supply Voltage to Allow for Temperature Compensation
- See Application Notes AN1066 and AN442

BLOCK DIAGRAM

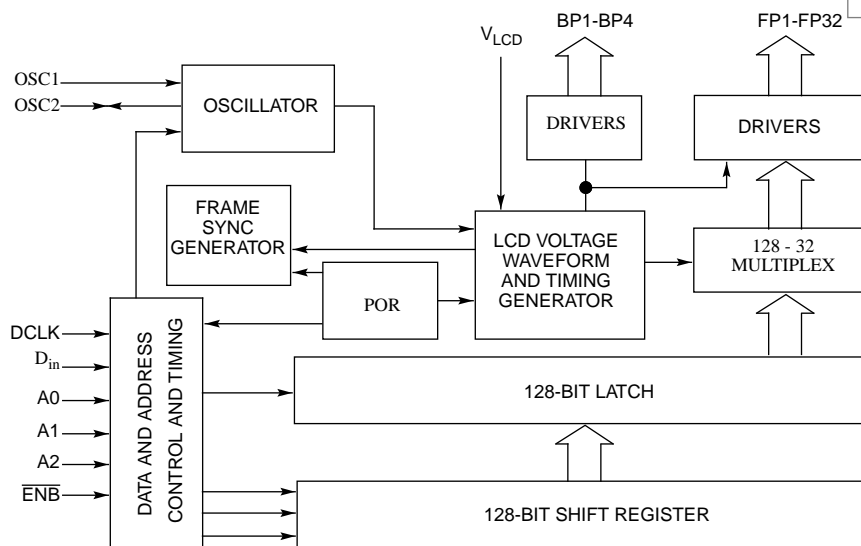

MC14LC5003

MC14LC5004

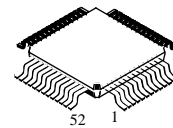

QFP
 FU SUFFIX
 CASE 848B

ORDERING INFORMATION

MC14LC5003FU QFP
 MC14LC5004FU QFP
 MCC14LC5003 BARE DIE
 MCC14LC5004 BARE DIE

PIN ASSIGNMENT

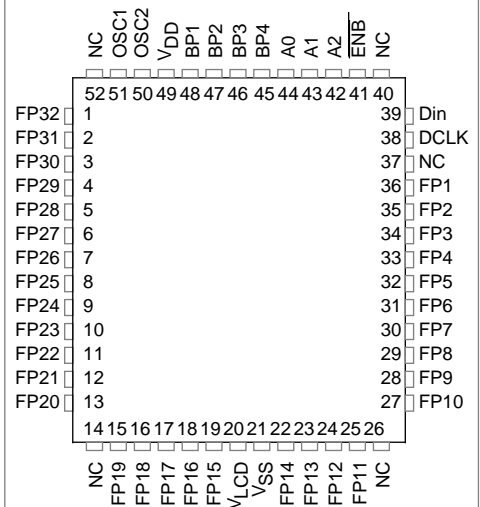

NC=NO CONNECTION

ABSOLUTE MAXIMUM RATINGS (Voltages Referenced to V_{SS})

Symbol	Parameter	Value	Unit
V_{DD}	DC Supply Voltage	- 0.5 to + 6.5	V
V_{in}	Input Voltage, D_{in} , and Data Clock	- 0.5 to 15	V
V_{in_osc}	Input Voltage, OSC_{in} of Master	- 0.5 to $V_{DD} + 0.5$	V
I_{in}	DC Input Current, per Pin	± 10	mA
T_A	Operating Temperature Range	- 40 to + 85	$^{\circ}C$
T_{stg}	Storage Temperature Range	- 65 to + 150	$^{\circ}C$

This device contains protection circuitry to guard against damage due to high static voltages or electric fields. However, precautions must be taken to avoid applications of any voltage higher than maximum rated voltages to this high-impedance circuit. This device may be light sensitive. Caution should be taken to avoid exposure of this device to any light source during normal operation. This device is not radiation protected.

* Maximum Ratings are those values beyond which damage to the device may occur. Functional operation should be restricted to the limits in the Electrical Characteristics tables or Pin Descriptions section.

ELECTRICAL CHARACTERISTICS (Voltages Referenced to V_{SS} , $T_A = 25^{\circ}C$)

Characteristic	Symbol	V_{DD} V	V_{LCD} V	Min	Typical	Max	Unit	
Output Drive Current — Frontplanes	$V_O = 0.15\text{ V}$	I_{FH}	5	2.7	260	—	—	μA
		I_{FL}	5	2.7	260	—	—	
	$V_O = 2.65\text{ V}$	I_{FH}	5	2.7	-240	—	—	
		I_{FL}	5	2.7	-240	—	—	
	$V_O = 1.72\text{ V}$	I_{FH}	5	2.7	-40	—	—	
		I_{FL}	5	2.7	—	—	-1.5	
	$V_O = 1.08\text{ V}$	I_{FH}	5	2.7	40	—	—	
		I_{FL}	5	2.7	—	—	2	
	$V_O = 0.15\text{ V}$	I_{FH}	5	5.5	600	—	—	
		I_{FL}	5	5.5	600	—	—	
	$V_O = 5.35\text{ V}$	I_{FH}	5	5.5	-520	—	—	
		I_{FL}	5	5.5	-520	—	—	
	$V_O = 3.52\text{ V}$	I_{FH}	5	5.5	-35	—	—	
		I_{FL}	5	5.5	—	—	-1.5	
$V_O = 1.98\text{ V}$	I_{FH}	5	5.5	55	—	—		
	I_{FL}	5	5.5	—	—	1		
Supply Standby Currents (No Clock)							μA	
$I_{DD} = \text{Standby @ } I_{out} = 0\text{ }\mu A$	I_{DDs}	2.7	—	—	—	30		
$I_{LCD} = \text{Standby @ } I_{out} = 0\text{ }\mu A$	I_{LCDs}	—	2.7	—	—	800		
$I_{DD} = \text{Standby @ } I_{out} = 0\text{ }\mu A$	I_{DDs}	5.5	—	—	—	50		
$I_{LCD} = \text{Standby @ } I_{out} = 0\text{ }\mu A$	I_{LCDs}	—	5.5	—	—	1500		
Supply Currents ($f_{OSC} = 110\text{ kHz}$)							μA	
$I_{DD} = \text{Quiescent @ } I_{out} = 0\text{ }\mu A, \text{ no loading}$	I_{DDQ}	2.7	—	—	30	—		
$I_{DD} = \text{Quiescent @ loading} = 270\text{ pF}$	I_{DDQ}	2.7	—	—	—	70		
$I_{DD} = \text{Quiescent @ } I_{out} = 0\text{ }\mu A, \text{ no loading}$	I_{DDQ}	5.5	—	—	170	—		
$I_{DD} = \text{Quiescent @ loading} = 270\text{ pF}$	I_{DDQ}	5.5	—	—	—	400		
$I_{LCD} = \text{Quiescent @ } I_{out} = 0\text{ }\mu A, \text{ no loading}$	I_{LCDQ}	—	2.7	—	—	40		
$I_{LCD} = \text{Quiescent @ } I_{out} = 0\text{ }\mu A, \text{ no loading}$	I_{LCDQ}	—	5.5	—	—	70		
Input Current	I_{in}	—	—	-0.1	—	0.1	μA	
Input Capacitance	C_{in}	—	—	—	—	7.5	pF	

(continued)

ELECTRICAL CHARACTERISTICS (Continued)

Characteristic	Symbol	V _{DD} V	V _{LCD} V	Min	Typical	Max	Unit
Frequencies							
OSC2 Frequency @ R1; R1 = 200 kΩ	f _{OSC2}	5	5	100	—	150	kHz
BP Frequency @ R1	f _{BP}	5	5	100	—	150	Hz
OSC2 Frequency @ R2; R2 = 996 kΩ	f _{OSC2}	5	5	23	—	33	kHz
Average DC Offset Voltage (BP Relative to FP)	V _{OO}	5	2.8	-50	—	+50	mV
Input Voltage							
“0” Level	V _{IL}	2.8	5	—	—	0.85	V
	V _{IL}	5.5	5	—	—	1.65	
“1” Level	V _{IH}	2.8	5	2	—	—	
	V _{IH}	5.5	5	3.85	—	—	
Output Drive Current — Backplanes							μA
V _O = 2.65 V	I _{BH} * I _{BL}	5 5	2.8 2.8	-240 -240	— —	— —	
V _O = 0.15 V	I _{BH} I _{BL}	5 5	2.8 2.8	260 260	— —	— —	
V _O = 1.08V	I _{BH} I _{BL}	5 5	2.8 2.8	40 —	— —	— 2	
V _O = 1.72 V	I _{BH} I _{BL}	5 5	2.8 2.8	-40 —	— —	— -1	
V _O = 5.35 V	I _{BH} I _{BL}	5 5	5.5 5.5	-520 -520	— —	— —	
V _O = 0.15 V	I _{BH} I _{BL}	5 5	5.5 5.5	600 600	— —	— —	
V _O = 1.98 V	I _{BH} I _{BL}	5 5	5.5 5.5	55 —	— —	— 1	
V _O = 3.52 V	I _{BH} I _{BL}	5 5	5.5 5.5	-35 —	— —	— -1	
Pulse Width, Data Clock (Figure 1)	t _w	5 3		50 100	— —	— —	ns
DCLK Rise/Fall Time (Figure 1)	t _r , t _f	5 3		— —	— —	20 120	μs
Setup Time, D _{in} to DCLK (Figure 2)	t _{su}	5 3		0 0	— —	— —	ns
Hold Time, D _{in} to DCLK (Figure 2)	t _h	5 3		30 60	— —	— —	ns
DCLK Low to $\overline{\text{ENB}}$ High (Figure 3)	t _h	5 3		10 20	— —	— —	ns
$\overline{\text{ENB}}$ High to DCLK High (Figure 3)	t _{rec}	5 3		10 20	— —	— —	ns
$\overline{\text{ENB}}$ High Pulse Width (Figure 3)	t _w	5 3		50 100	— —	— —	ns
$\overline{\text{ENB}}$ Low to DCLK High (Figure 3)	t _{su}	5 3		10 20	— —	— —	ns

NOTE: Timing for Figures 1, 2, and 3 are design estimates only.

* For a time (t = 4/OSC FREQ.) after the backplane waveform changes to a new voltage level, the circuit is maintained in the high-current state to allow the load capacitances to charge quickly. The circuit is then returned to the low-current state until the next voltage change.

SWITCHING WAVEFORMS

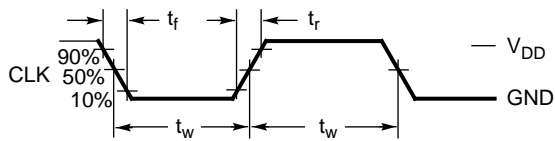

Figure 1.

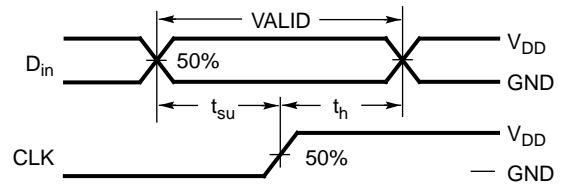

Figure 2.

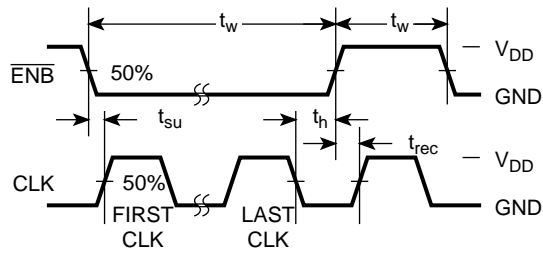

Figure 3.

FUNCTIONAL DESCRIPTION

The MC14LC5003/MC14LC5004 has essentially two sections which operate asynchronously from each other; the data input and storage section and the LCD drive section. The LCD drive and timing is derived from the oscillator, while the data input and storage is controlled by the Data In (D_{in}), Data Clock (DCLK), Address (A0, A1, A2), and Enable (\overline{ENB}) pins.

Data is shifted serially into the 128-bit shift register and arranged into four consecutive blocks of 32 parallel data bits. A time-multiplex of the four backplane drivers is made (each backplane driver becoming active then inactive one after another) and, at the start of each backplane active period, the corresponding block of 32 bits is made available at the frontplane drivers. A high input to a plane driver turns the driver on, and a low input turns the driver off.

Figure 4 shows the sequence of backplanes. Figure 5 shows the possible configurations of the frontplanes relative to the backplanes. When a backplane driver is on, its output switches

from V_{LCD} to 0 V, and when it is off, it switches from $1/3 V_{LCD}$ to $2/3 V_{LCD}$. When a frontplane driver is on, its output switches from 0 V to V_{LCD} , and when it is off, it switches from $2/3 V_{LCD}$ to $1/3 V_{LCD}$.

The LCD drive and timing section provides the multiplex signals and backplane driver input signals and formats the frontplane and backplane waveforms.

The address pins are used to uniquely distinguish LCD driver from any other chips on the same bus and to define LCD driver as the "master" in the system. There must be one master in any system.

The enable pin may be used as a third control line in the communication bus. It may be used to define the moment when the data is latched. If not used, then the data is latched after 128 bits of data have been received.

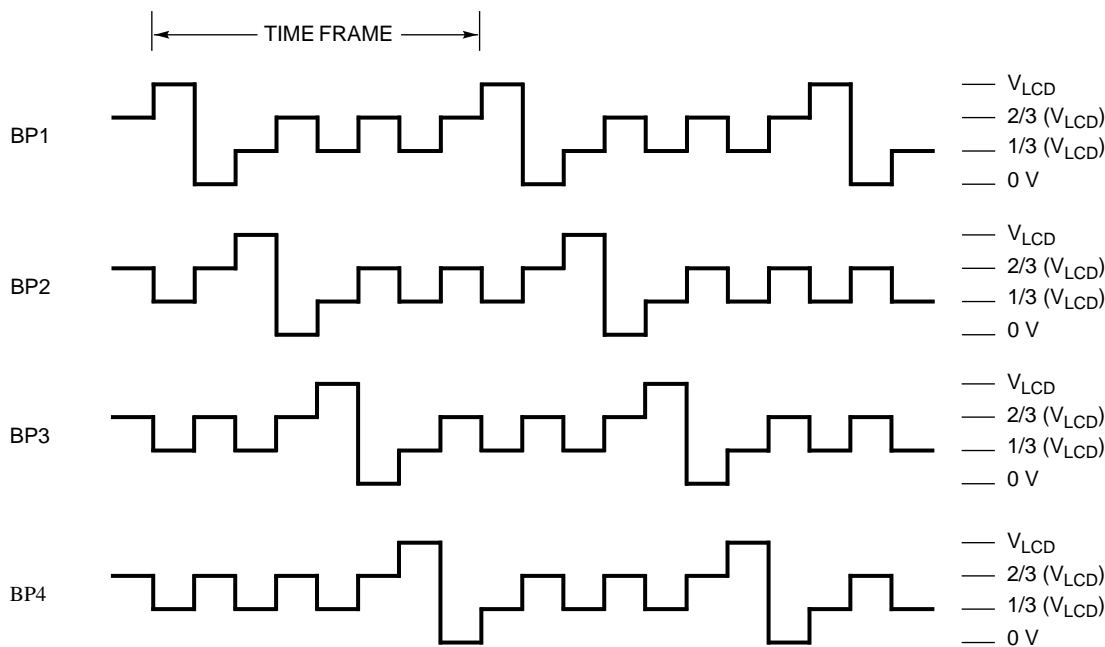

Figure 4. Backplane Sequence

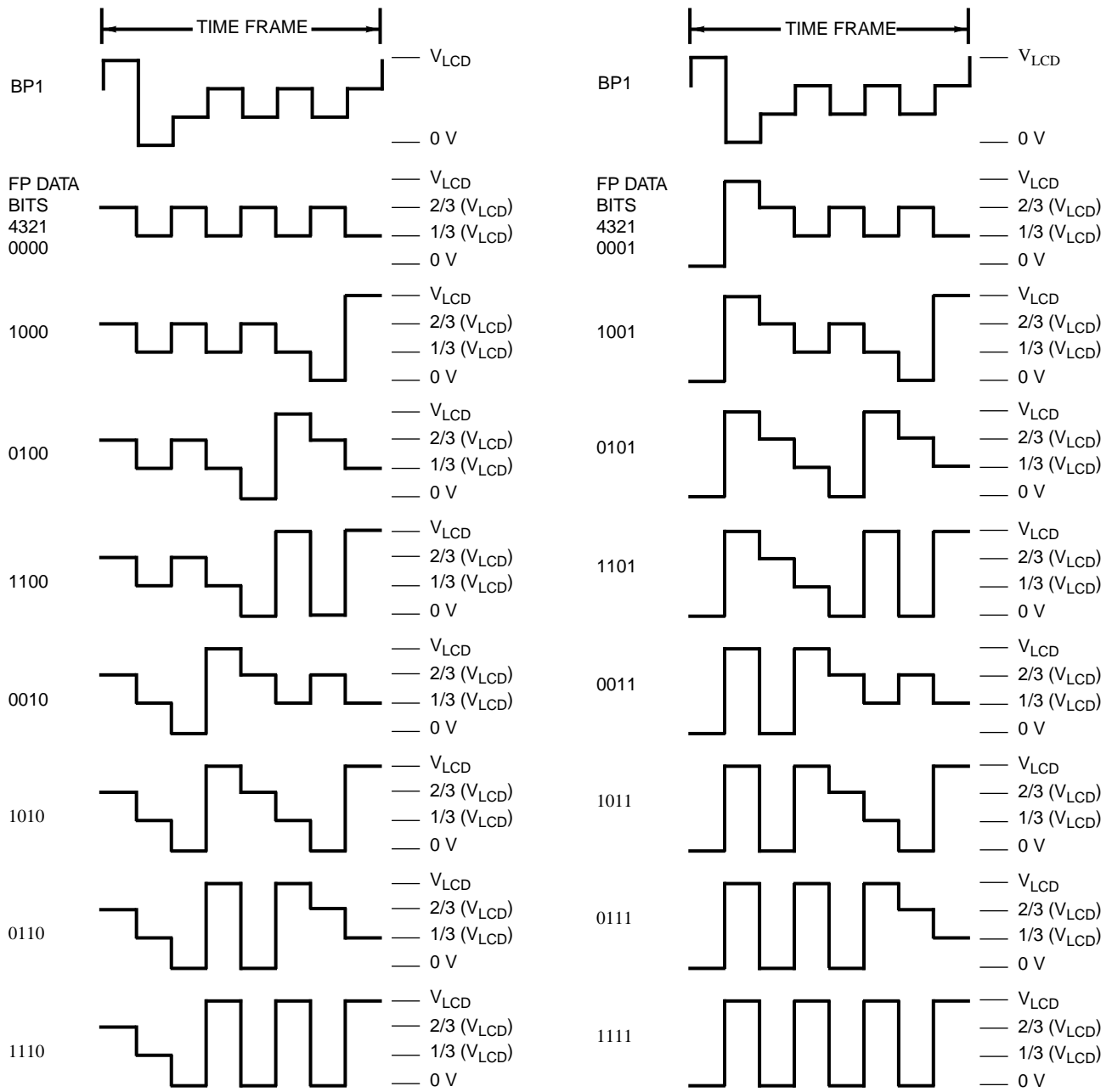

Figure 5. Frontplane Combinations

PIN DESCRIPTIONS

A0-A2

Address Inputs (Pins 42-44)

The devices have to receive a correct address before they will accept data. Three address pins (A2, A1, A0) are used to define the states of the three programmable bits of MC14LC5003/MC14LC5004's 8-bit address.

The address is 0111vwxy where v, w, x represent A2, A1, and A0 respectively. Where v, w, x=0, then A2, A1, and A0 should be tied to 0 V. Where v, w, x=1, then A2, A1, and A0 should be tied to V_{DD} .

The address pins must be tied to V_{DD} . This defines the device as a master.

NOTE

Note: In applications where the circuit will be isolated from external manual interference the system designer may take advantage of the self-programming feature. Upon power-on, address pins which are left open-circuit will be charged to V_{DD} . However, care must be taken not to inadvertently discharge the pins after power-on since the address may then be lost. A similar feature is also available on the \overline{ENB} pin.

CAUTION

The configuration A0, A1, A2 = 000 should not be used. This does not give a valid address and is reserved for Motorola's use only. All three address pins should never be tied to 0 V simultaneously.

\overline{ENB}

Enable Input (Pin 41)

If the \overline{ENB} pin is tied to V_{DD} , the MC14LC5003/MC14LC5004 will always latch the data after 128 bits have been received. The latched data is multiplexed and fed to the frontplane drivers for display. If external control of this latching function is required, then the \overline{ENB} pin should be held low, followed by one high pulse on \overline{ENB} when data display is required. (This may be useful in a system where one MC145003/MC145004 is permanently addressed and only the last 128 bits of data sent are required to be latched for display). The pulse on the \overline{ENB} pin must occur while DCLK is high.

DCLK, D_{in}

Data Clock and Data Input (Pins 38, 39)

Address input and data input controls. See **Data Input Protocol** sections for relevant option.

OSC1, OSC2

Oscillator Pins (Pins 51, 50)

To use the on-board oscillator, an external resistor should be connected between OSC1 and OSC2. Optionally, the OSC1 pin may be driven by an externally generated clock signal.

A resistor of 680 k connected between OSC1 and OSC2 pins gives an oscillator frequency of about 30 kHz, giving approximately 30 Hz as seen at the LCD driver outputs. A resistor of 200 k gives about 100 kHz, which results in 100 Hz at the driver outputs. LCD manufacturers recommend an LCD drive frequency of between 30 Hz and 100 Hz. See Figure 6.

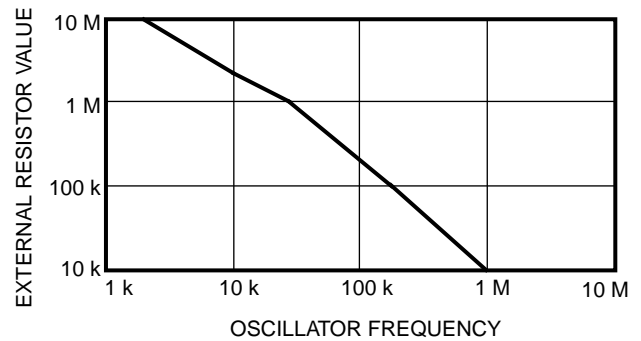

Figure 6. Oscillator Frequency vs. Load Resistance (Approximate)

FP1-FP32

Frontplane Drivers (Pins 36-27, 25-22, 19-15, 13-1)

Frontplane driver outputs.

BP1-BP4

Backplane Drivers (Pins 48-45)

Backplane driver outputs.

V_{LCD}

LCD Driver Supply (Pin 20)

Power supply input for LCD drive outputs. May be used to supply a temperature-compensated voltage to the LCD drive section, which can be separate from the logic voltage supply, V_{DD} .

V_{DD}

Positive Power Supply (Pin 49)

This pin supplies power to the main processor interface and logic portions of the device. The voltage range is 2.7 to 5.5 V with respect to the V_{SS} pin.

For optimum performance, V_{DD} should be bypassed to V_{SS} using a low inductance capacitor mounted very closely to these pins. Lead length on this capacitor should be minimized.

V_{SS}

Ground (Pin 21)

Common ground.

DATA INPUT PROTOCOL

Two-wire communication bus DCLK, D_{in} ; three-wire communication bus DCLK, D_{in} , \overline{ENB} .

MC14LC5003 — SERIAL INTERFACE DEVICE (FIGURE 7)

Before communication with an MC14LC5003 can begin, a start condition must be set up on the bus by the transmitter. To establish a start condition, the transmitter must pull the data line low while the clock line is high. The "idle" state for the clock line and data line is the high state.

After the start condition has been established, an eight-bit address should be sent by the transmitter. If the address sent corresponds to the address of the MC14LC5003 then on each

successive clock pulse, the addressed device will accept a data bit.

If the $\overline{\text{ENB}}$ pin is permanently high, then the addressed MC14LC5003's internal counter latches the data to be displayed after 128 data bits have been received. Otherwise, the control of this latch function may be overridden by holding the $\overline{\text{ENB}}$ line low until the new data is required to be displayed, then a high pulse should be sent on the $\overline{\text{ENB}}$ line. The high pulse must be sent during DCLK high (clock idle).

To end communication with an MC14LC5003, a stop condition should be set up on the bus (or another start condition may be set up if another communication is desired). Note that the communication channel to an addressed device may be left open after the 128 data bits have been sent by not setting up a stop or a start condition. In such a case, the 129th rising DCLK edge, which normally would be used to set up the stop or start condition, is ignored by the MC14LC5003 and data continues to be received on the 130th rising DCLK. The latch function continues to work as normal (i.e., data is latched either after each block of 128 data bits has been received or under external control as required).

At any time during data transmission, the transfer may be interrupted with a stop condition. Data transmission may be resumed with a start condition and resending the address.

MC14LC5004 — IIC DEVICE (FIGURE 8)

Before communication with an MC14LC5004 can begin, a start condition must be set up on the bus by the controller. To establish a start condition, the controller must pull the data line low while the clock line is high.

After the start condition has been established, an eight-bit address should be sent by the controller followed by an extra clock pulse while the data line is left high. In this option, only the seven most significant bits of the address are used to uniquely define devices on the bus, the least significant bit is used as a read/write control: if the least significant bit is 0, then the controller writes to the LCD driver; if it is 1, then the

controller reads from the LCD driver's 128-bit shift register on a first-in first-out basis. If the seven most significant address bits sent correspond to the address of the LCD driver then the addressed LCD driver responds by sending an "acknowledge" bit back to the controller (i.e., the LCD driver pulls the data line low during the extra clock pulse supplied by the controller). If the least significant address bit was 0, then the controller should continue to send data to the LCD driver in blocks of eight bits followed by an extra ninth clock pulse to allow the LCD driver to pull the data line D_{in} low as an acknowledgment. If the least significant address bit was 1, then the LCD driver sends data back to the controller (the clock is supplied by the controller). After each successive group of eight bits sent, the LCD driver leaves the data line high for one pulse.

If the $\overline{\text{ENB}}$ pin is permanently high, then the addressed MC14LC5004's internal counter latches the data to be displayed after 128 data bits have been received. Otherwise the control of this latch function may be overridden by holding the $\overline{\text{ENB}}$ line low until the new data is required to be displayed, then a high pulse should be sent on the $\overline{\text{ENB}}$ line. The high pulse must be sent during DCLK high (clock idle).

To end communication with an MC14LC5004, a stop condition should be set up on the bus (or another start condition may be set up if another communication is desired). Note that the communication channel to an addressed device may be left open after the 128 data bits have been sent by not setting up a stop or a start condition. In such a case the rising DCLK edge which comes after all 128 data bits have been sent and after the last acknowledge-related clock pulse has been made is ignored; data continues to be received on the following DCLK high. The latch function continues to work as normal (i.e., data is latched either after each block of 128 data bits has been received or under external control as required).

At any time during data transmission, the transfer may be interrupted with a stop condition. Data transmission may be resumed with a start condition and resending the address.

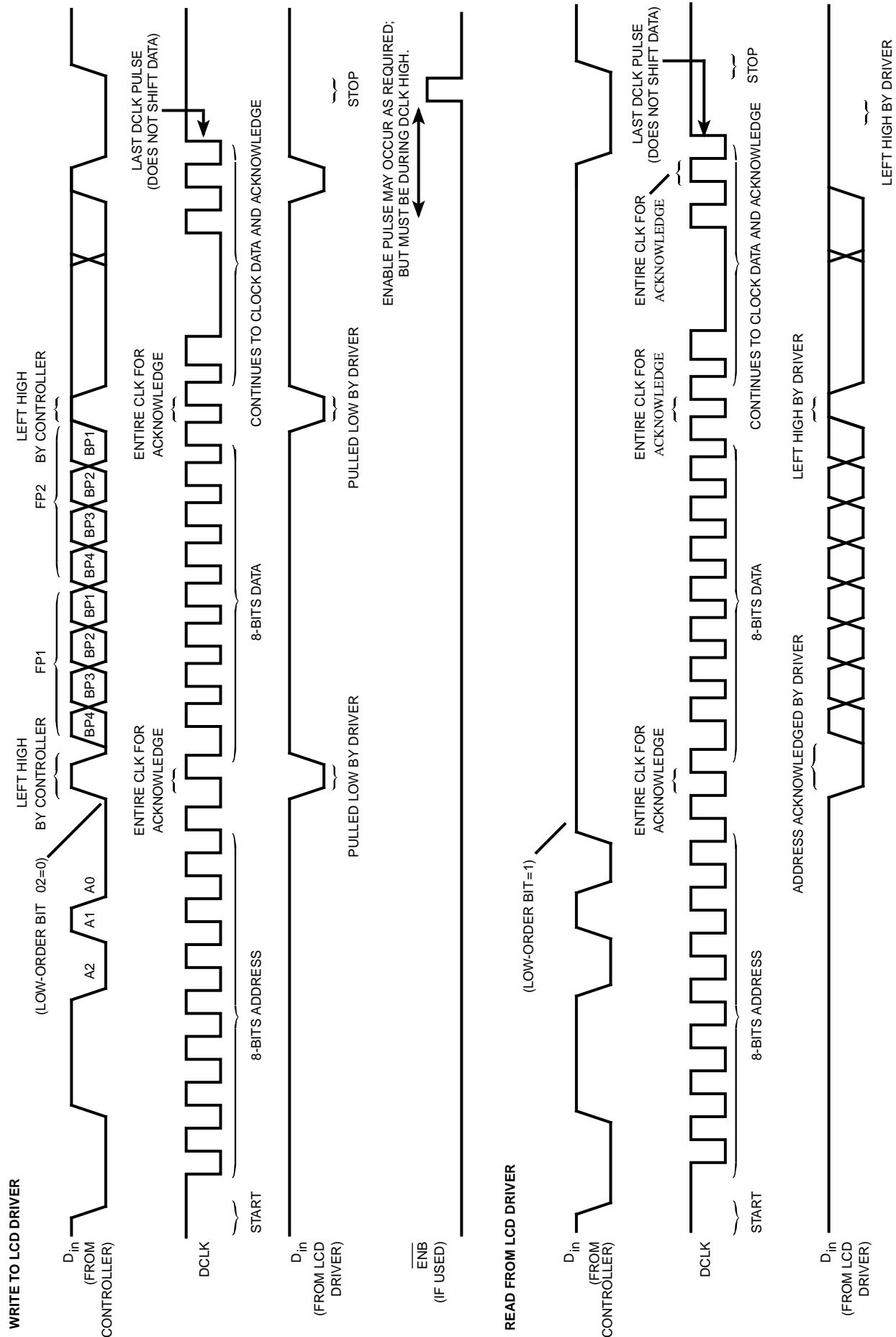

Figure 8 . Data Input MC14LC5004 (IIC Device)

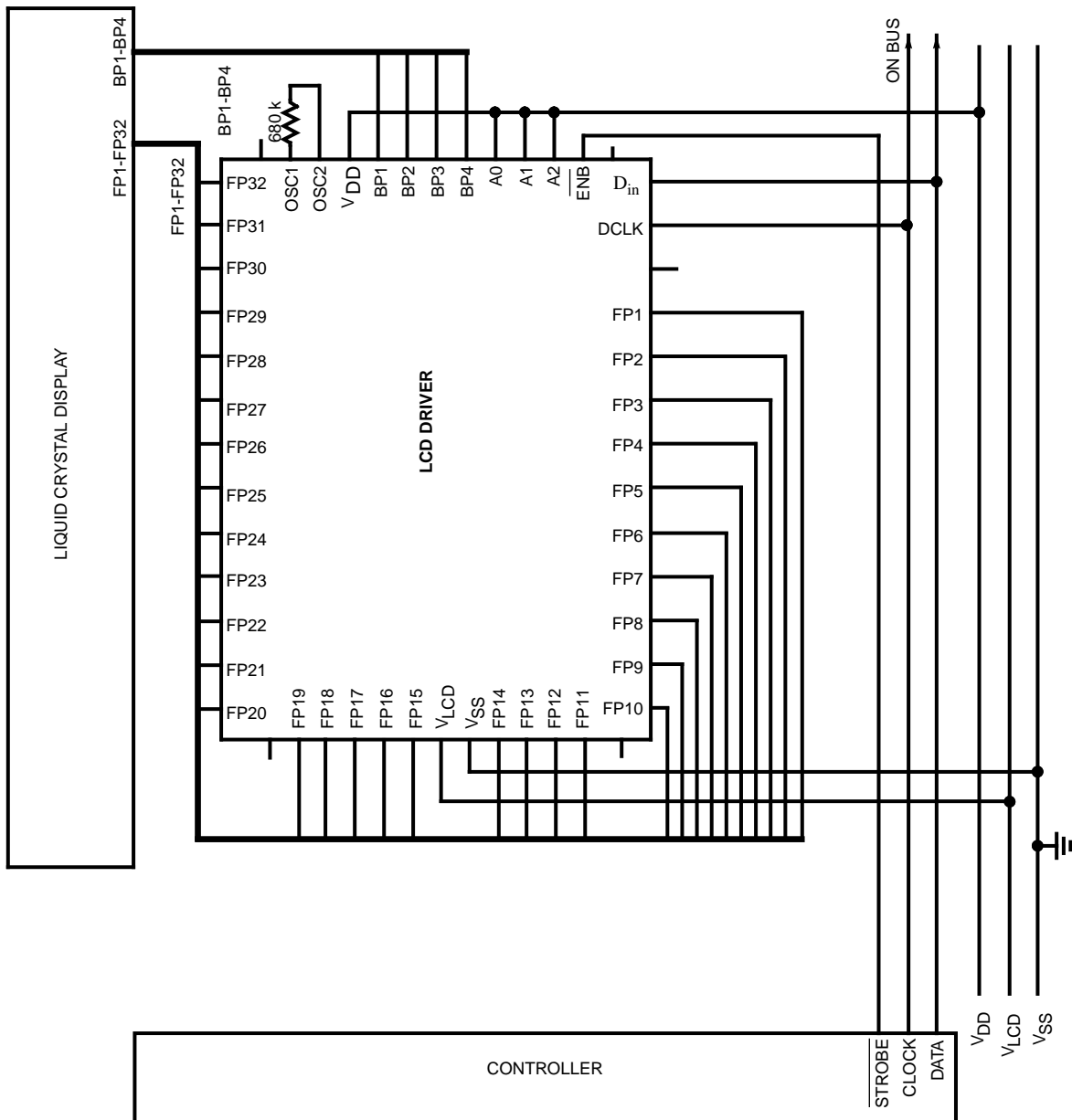

Figure 9. Application Example

APPLICATION INFORMATION

Figure 10 shows an interface example.

Example shows a semi-automatic SPI Mode (only start and stop conditions are done in non-SPI Mode). It contains the software to use HC11 with MC14LC5003 in manual SPI Mode.

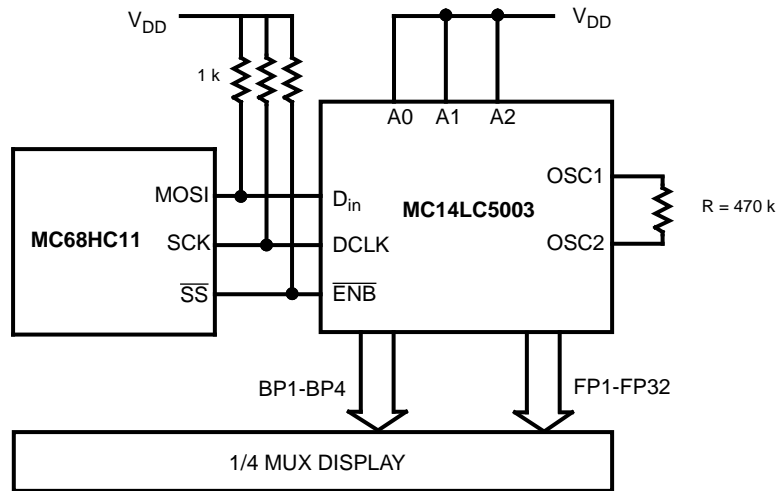

Figure 10. Interface Example Between MC68HC11 and MC14LC5003

```

1
2          ;=====CONSTANTS=====
3 0000 T      extram      equ      $A000          ;$A000 for 8K RAM
4 0000 T      stack      equ      $00FF         ;last RAM byte
5 0000 T      intofs     equ      $1000        ;Internal Registers
6 0000 T      data       equ      $08
7 0000 T      clock      equ      $10
8 0000 T      enable     equ      $20
9 0000 T      portd      equ      8
10
11
12          ;=====PROGRAM BEGIN=====
13 A000 T      cold       org      extram       ;Program into RAM
14 A000 N      8E00FF     lds      #stack      ;set stack pointer
15 A003 M      8638      ldaa     #$38        ;set of MOSI,SS,SCK
16 A005 T      B71009    staa     $1009        ;DDRD
17 A008 M      C611      ldab     #17
18 A00A N      CEA05E    ldx      #send
19 A00D T      BDA010    jsr      spi
20 A010 T      end
21
22 A010 U      18CE1000   spi      ldy      #intofs
23 A014 J      181D0820   bclr    portd,y #enable    ;EN = 0
24 A018 T      BDA031    jsr      start        ;start condition
25 A01B X      A600      again    ldaa     0 , x          ;SPI Mode Use
26 A01D T      B7102A    staa     $102A        ;SPDR
27 A020 L      181F2980FB brclr   $29,y,#$80,*
28 A025 H      08        inx
29 A026 H      5A        decb
30 A027 R      26F2      bne     again
31 A029 J      181C0820   bset   portd,y #enable    ;next DATA
32 A02D T      BDA04C    jsr      stop          ;stop condition
33 A030 H      39        rts
34
35 A031 M      8633      start    ldaa     #$33          ;Normal Mode
36 A033 T      B71028    staa     $1028        ;SPCR

```

```

37 A036 J 181C0808          bset      portd,y #data      ;DATA = 1
38 A03A J 181C0810          bset      portd,y #clock    ;CLK = 1
39 A03E J 181D0808          bclr      portd,y #data      ;DATA = 0
40 A042 J 181D0810          bclr      portd,y #clock    ;CLK = 0
41 A046 M 8673              ldaa      #$73             ;SPI Mode
42 A048 T B71028           staa      $1028            ;SPCR
43 A04B H 39                rts
44 A04C M 8633              stop      ldaa      #$33             ;Normal Mode
45 A04E T B71028           staa      $1028            ;SPCR
46 A051 J 181D0808          bclr      portd,y #data      ;DATA = 0
47 A055 J 181C0810          bset      portd,y #clock    ;CLK = 1
48 A059 J 181C0808          bset      portd,y #data      ;DATA = 0
49 A05D H 39                rts
50
51 A05E T 7E                send      fcb      $007E             ;LCD Driver Address
52 A05F T F0                fcb      $00f0             ;Data to send
53 A060 T F0                fcb      $00f0
54 A061 T F0                fcb      $00f0
55 A062 T F0                fcb      $00f0
56 A063 T F0                fcb      $00f0
57 A064 T F0                fcb      $00f0
58 A065 T F0                fcb      $00f0
59 A066 T F0                fcb      $00f0
60 A067 T F0                fcb      $00f0
61 A068 T F0                fcb      $00f0
62 A069 T F0                fcb      $00f0
63 A06A T F0                fcb      $00f0
64 A06B T F0                fcb      $00f0
65 A06C T F0                fcb      $00f0
66 A06D T F0                fcb      $00f0
67 A06E T F0                fcb      $00f0
68 A06F H 39                rts
69
70                          ;=====PROGRAM END=====

```

Example 1. Semi-Automatic SPI Method

Figure 11 shows another interface example.

Example 2 contains the software to use HC05 with MC14LC5003 in serial data interface.

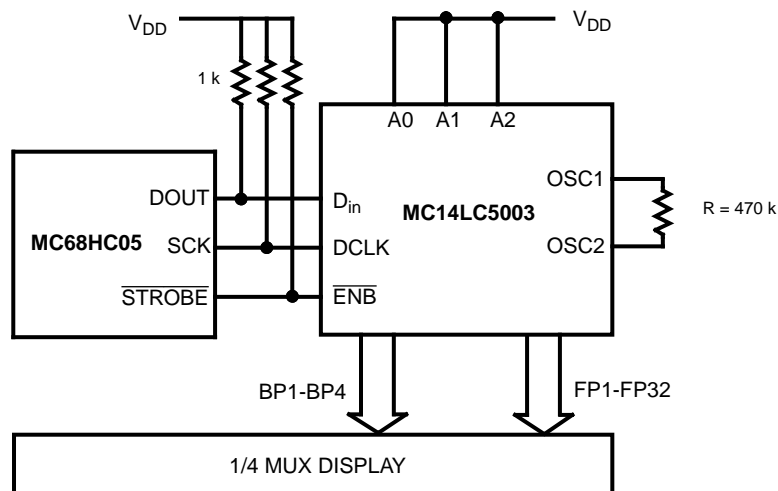

Figure 11. Interface Example Between MC68HC05 and MC14LC5003

```

PORTC EQU $02      PORTC
DDRC EQU $06      PORTDC
SEN EQU $07      ENABLE PIN, PC7
SCL EQU $06      CLOCK PIN, PC6
SDA EQU $05      DATA PIN, PC5
DOUT EQU $FF      OUTPUT DATA

                ORG $0050

W1 RMB 1
COUNT RMB 1

                ORG $1FFE      ADDRESS OF RESET VECTOR OF MC68HC805C4
                FCB #$01      RESET VECTOR
                FCB #$00

*** Main Program start at 0100 ***

START ORG $0100
      LDA #DOUT      SET DATA LINE OUTPUT
      STA DDRC

AGAIN
      LDX #$00
      BSET SDA,PORTC  IDLE STATE
      BSET SCL,PORTC  CLOCK AND DATA ARE HIGH

READY BSET SEN,PORTC  EN=1
      LDA #$11      SET ADDRESS AND 8 CHARACTERS
      STA W1
      BCLR SDA,PORTC  START CONDITION, DATA LOW WHILE CLOCK HIGH

LBYTE CLC
      LDA #$08
      STA COUNT      8 BITS TO SHIFT
      LDA SEND,X     GET A BYTE
      INCX

LBIT BCLR SCL,PORTC  CLOCK LOW
      ROLA
      BCC DZERO      DATA BIT=0 ?
      BSET SDA,PORTC  NO, BIT=1 AND DATA HIGH
      JMP CLKHI

DZERO BCLR SDA,PORTC  DATA LOW
CLKHI BSET SCL,PORTC  CLOCK HIGH
      DEC COUNT
      BNE LBIT
      DEC W1
      BNE LBYTE      LAST BYTE ?

STOP BCLR SCL,PORTC
      BCLR SDA,PORTC  STOP CONDITION
      BSET SCL,PORTC  DATA GOES HIGH WHILE CLOCK HIGH
      BSET SDA,PORTC
      BCLR SEN,PORTC  EN=0
      RTS

*** End of Program ***

*** LCD Address and Data ***

SEND FCB $7E          LCD DRIVER ADDRESS
      FCB $FF, $FF, $FF, $FF, $FF, $FF, $FF, $FF  DATA TO SENT
      FCB $FF, $FF, $FF, $FF, $FF, $FF, $FF, $FF
      RTS

```

Example 2. Serial Data Interface Method

PACKAGE DIMENSIONS

QFP
FU SUFFIX
CASE 848B-02

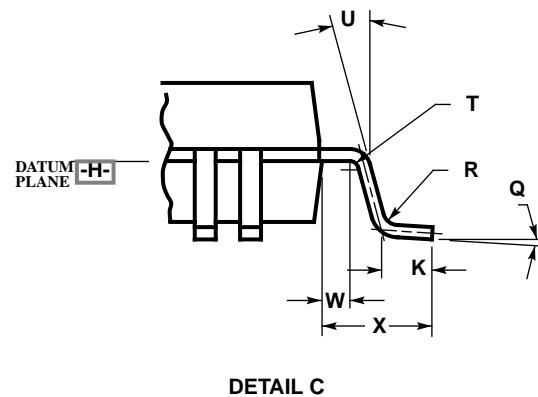
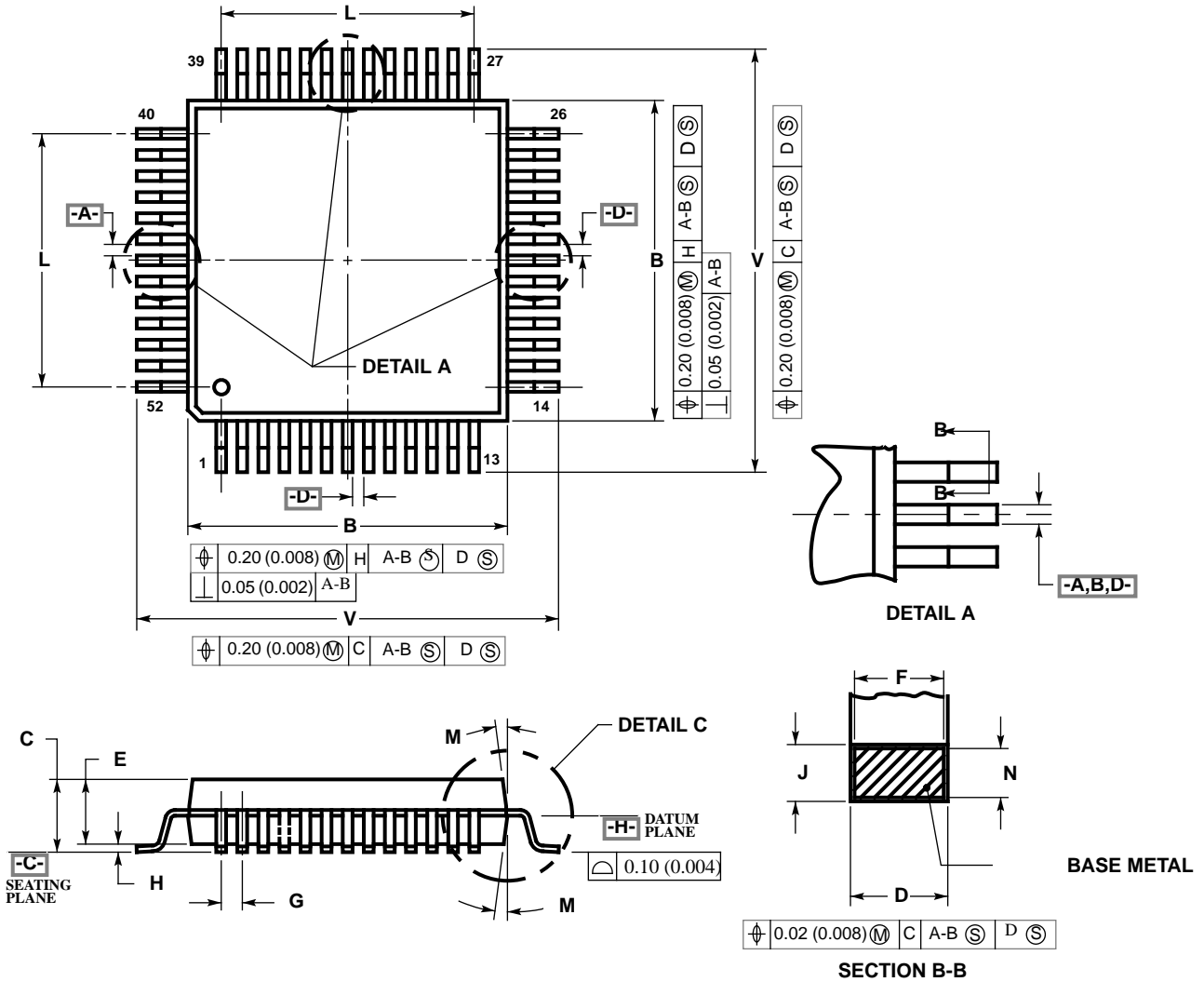

NOTES:

1. DIMENSIONING AND TOLERANCING PER ANSI Y14.5M, 1982.
2. CONTROLLING DIMENSION: MILLIMETER.
3. DATUM PLANE -H- IS LOCATED AT BOTTOM OF LEAD AND IS COINCIDENT WITH THE LEAD WHERE THE LEAD EXITS THE PLASTIC BODY AT THE BOTTOM OF THE PARTING LINE.
4. DATUMS -A-, -B- AND -D- TO BE DETERMINED AT DATUM PLANE -H-.
5. DIMENSIONS S AND V TO BE DETERMINED AT SEATING PLANE -C-.
6. DIMENSIONS A AND B DO NOT INCLUDE MOLD PROTRUSION. ALLOWABLE PROTRUSION IS 0.25 (0.010) PER SIDE. DIMENSIONS A AND B DO INCLUDE MOLD MISMATCH AND ARE DETERMINED AT DATUM PLANE -H-.
7. DIMENSION D DOES NOT INCLUDE DAMBAR PROTRUSION. ALLOWABLE DAMBAR PROTRUSION SHALL BE 0.08 (0.003) TOTAL IN EXCESS OF THE D DIMENSION AT MAXIMUM MATERIAL CONDITION. DAMBAR CANNOT BE LOCATED ON THE LOWER RADIUS OR THE FOOT.

DIM	MILLIMETERS		INCHES	
	MIN	MAX	MIN	MX
A	9.90	10.10	0.390	0.398
B	9.90	10.10	0.390	0.398
C	2.10	2.45	0.083	0.096
D	0.22	0.38	0.009	0.015
E	2.00	2.10	0.079	0.083
F	0.22	0.33	0.009	0.013
G	0.65 BSC		0.026 BSC	
H	--	0.25	--	0.010
J	0.13	0.23	0.005	0.009
K	0.65	0.95	0.026	0.037
L	7.80 REF		0.307 REF	
M	5"	10"	5"	10"
N	0.13	0.17	0.005	0.007
Q	0"	7"	0"	7"
R	0.13	0.30	0.005	0.012
S	12.95	13.45	0.510	0.530
T	0.13	--	0.005	--
U	0"	--	0"	--
V	12.95	13.45	0.510	0.530
W	0.35	0.45	0.014	0.018
X	1.6 REF		0.063 REF	

BOND PAD LAYOUT

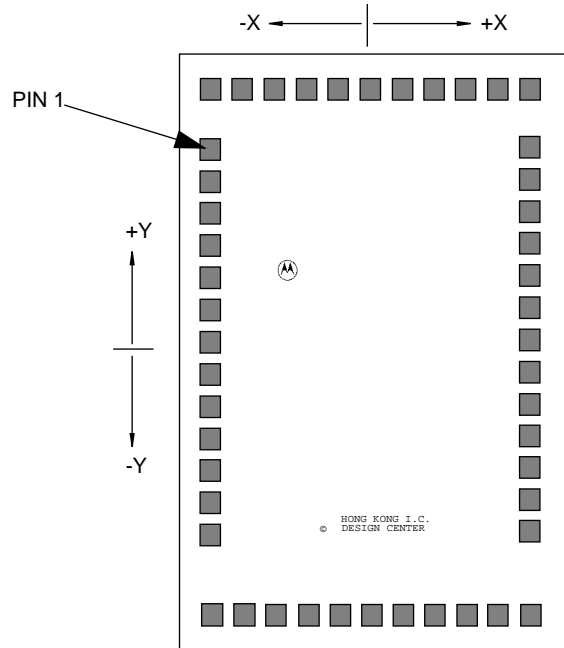

Die size : 78 x 119 mil²
(1 mil ~ 25.4µm)

BOND PAD COORDINATES

PIN NO.	PIN NAME	COORDINATES	
		X	Y
1	FP32	-736.002	929.199
2	FP31	-736.002	781.999
3	FP30	-736.002	634.799
4	FP29	-736.002	487.599
5	FP28	-736.002	340.399
6	FP27	-736.002	193.199
7	FP26	-736.002	45.999
8	FP25	-736.002	-101.201
9	FP24	-736.002	-248.401
10	FP23	-736.002	-395.601
11	FP22	-736.002	-542.801
12	FP21	-736.002	-690.001
13	FP20	-736.002	-837.201
14	NC	N/A	N/A
15	FP19	-736.002	-1205.601
16	FP18	-588.802	-1205.601
17	FP17	-441.602	-1205.601
18	FP16	-294.402	-1205.601
19	FP15	-147.202	-1205.601
20	V _{LCD}	0.000	-1205.600
21	V _{SS}	147.200	-1205.600
22	FP14	294.398	-1205.601
23	FP13	441.598	-1205.601
24	FP12	588.798	-1205.601
25	FP11	735.998	-1205.601
26	NC	N/A	N/A

PIN NO.	PIN NAME	COORDINATES	
		X	Y
27	FP10	735.998	-837.201
28	FP9	735.998	-690.001
29	FP8	735.998	-542.801
30	FP7	735.998	-395.601
31	FP6	735.998	-248.401
32	FP5	735.998	-101.201
33	FP4	735.998	45.999
34	FP3	735.998	193.199
35	FP2	735.998	340.399
36	FP1	735.998	487.599
37	NC	736.000	634.800
38	DCLK	736.000	782.000
39	D _{IN}	736.000	929.200
40	NC	N/A	N/A
41	ENB	736.000	1205.600
42	A2	588.800	1205.600
43	A1	441.600	1205.600
44	A0	294.400	1205.600
45	BP4	147.198	1205.599
46	BP3	-0.002	1205.599
47	BP2	-147.202	1205.599
48	BP1	-294.402	1205.599
49	V _{DD}	-441.600	1205.600
50	OSC2	-588.800	1205.600
51	OSC1	-736.000	1205.600
52	NC	N/A	N/A

Dimensions in µm