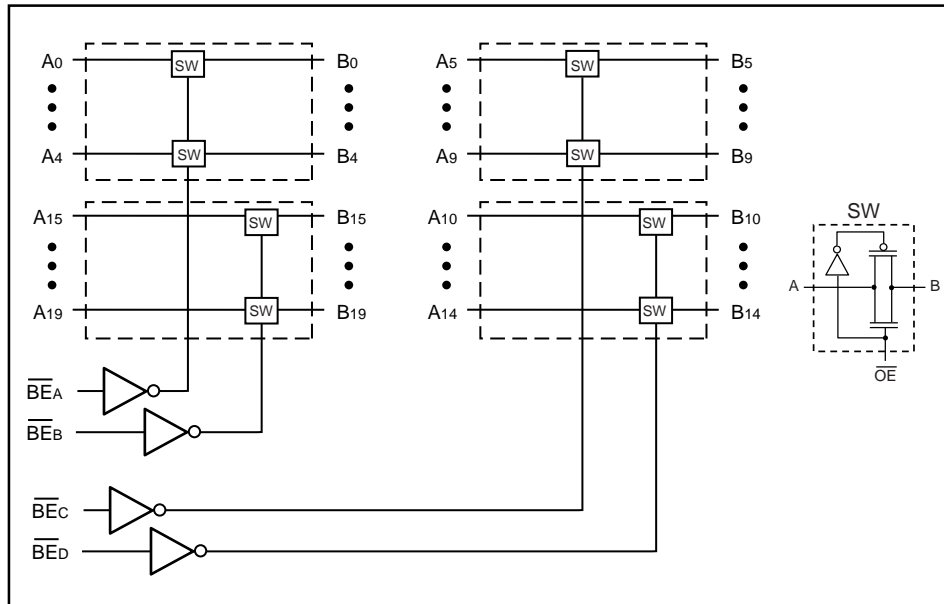
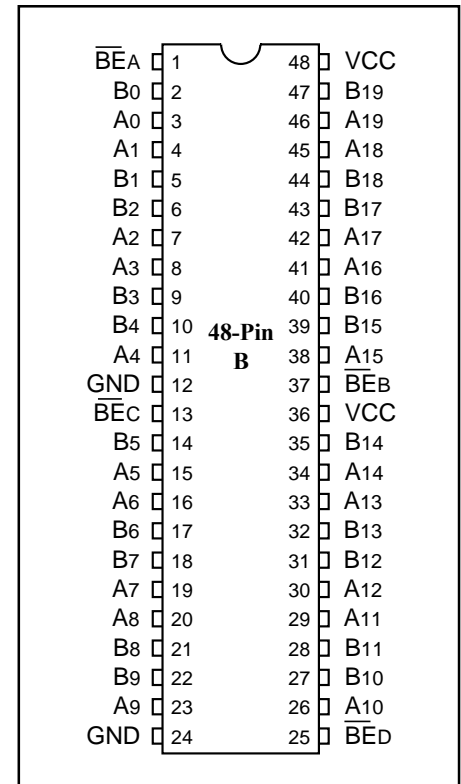

**Features**

- Near-Zero propagation delay
- 5-ohm switches connect inputs to outputs
- Direct bus connection when switches are ON
- Ultra-low quiescent power 32X384 (0.1µA typical)
  - Ideally suited for notebook applications
- Fast Switching Speed - 4.5ns max.
- TTL - compatible control of input levels
- Packaging (pb-free & Green available):
  - 48-pin 150-mil wide plastic BQSOP (B)

**Description**

Pericom Semiconductor's PI3B32X384 is a 3.3V, 20-bit bus switch designed with a low On-Resistance allowing inputs to be connected directly to outputs. The bus switch creates no additional propagational delay or additional ground bounce noise. The switches are turned ON by the Bus Enable ( $\overline{BE}$ ) input signal. Four bus enable signals are provided, one for each of the upper and lower five bits of the two 10-bit buses.

**Block Diagram**

**Pin Configuration**

**Truth Table<sup>(1)</sup>**

Function	$\overline{BEA}$	$\overline{BEB}$	B4-B0	B19-B15
Disconnect	H	H	Hi-Z	Hi-Z
Connect	L	H	A4-A0	Hi-Z
Connect	H	L	Hi-Z	A19-A15
Connect	L	L	A4-A0	A19-A15
Function	$\overline{BEC}$	$\overline{BED}$	B9-B5	B14-B10
Disconnect	H	H	Hi-Z	Hi-Z
Connect	L	H	A9-A5	Hi-Z
Connect	H	L	Hi-Z	A14-A10
Connect	L	L	A9-A5	A14-A10

**Pin Description**

Pin Name	Description
$\overline{BE}x$	Bus Enable Inputs (Active LOW)
A19-A0	Bus A
B19-B0	Bus B
GND	Ground
Vcc	Power

**Note:** 1. H=High Voltage Level L=Low Voltage Level  
Hi-Z=High Impedance

### Maximum Ratings

(Above which the useful life may be impaired. For user guidelines, not tested.)

Storage Temperature .....	-65°C to +150°C
Ambient Temperature with Power Applied .....	-40°C to +85°C
Supply Voltage to Ground Potential .....	-0.5V to +4.6V
DC Input Voltage .....	-0.5V to +4.6V
DC Output Current .....	120mA
Power Dissipation .....	0.5W

**Note:**

Stresses greater than those listed under MAXIMUM RATINGS may cause permanent damage to the device. This is a stress rating only and functional operation of the device at these or any other conditions above those indicated in the operational sections of this specification is not implied. Exposure to absolute maximum rating conditions for extended periods may affect reliability.

### DC Electrical Characteristics (Over the Operating Range, T<sub>A</sub> = -40°C to +85°C, V<sub>CC</sub> = 3.3V ± 10%)

Parameters	Description	Test Conditions(1)	Min.	Typ <sup>(2)</sup>	Max.	Units
V <sub>IH</sub>	Input HIGH Voltage	Guaranteed Logic HIGH Level	2.0	—	—	V
V <sub>IL</sub>	Input LOW Voltage	Guaranteed Logic LOW Level	-0.5	—	0.8	V
I <sub>IH</sub>	Input HIGH Current	V <sub>CC</sub> = Max., V <sub>IN</sub> = V <sub>CC</sub>	—	—	±1	μA
I <sub>IL</sub>	Input LOW Current	V <sub>CC</sub> = Max., V <sub>IN</sub> = GND	—	—	±1	μA
I <sub>OZH</sub>	High-Impedance Output Current	0 ≤ A, B ≤ V <sub>CC</sub>	—	—	±1	μA
V <sub>IK</sub>	Clamp Diode Voltage	V <sub>CC</sub> = Min., I <sub>IN</sub> = -18mA	—	—	-1.2	V
R <sub>ON</sub>	Switch ON Resistance <sup>(4)</sup>	V <sub>CC</sub> = Min., V <sub>IN</sub> = 0.0V I <sub>ON</sub> = 15mA	—	5	8	Ohm
		V <sub>CC</sub> = Min., V <sub>IN</sub> = 2.4V I <sub>ON</sub> = 15mA	—	10	17	

### Capacitance (T<sub>A</sub> = 25°C, f = 1 MHz)

Parameters(5)	Description	Test Conditions	Typ	Max.	Units
C <sub>IN</sub>	Input Capacitance	V <sub>IN</sub> = 0V	—	3.0	pF
C <sub>OFF</sub>	A/B Capacitance, Switch Off	V <sub>IN</sub> = 0V	—	8.0	pF
C <sub>ON</sub>	A/B Capacitance, Switch On	V <sub>IN</sub> = 0V	—	16.0	pF

**Notes:**

- For Max. or Min. conditions, use appropriate value specified under Electrical Characteristics for the applicable device type.
- Typical values are at V<sub>CC</sub> = 3.3V, T<sub>A</sub> = 25°C ambient and maximum loading.
- Not more than one output should be shorted at one time. Duration of the test should not exceed one second.
- Measured by the voltage drop between A and B pin at indicated current through the switch. ON resistance is determined by the lower of the voltages on the two (A,B) pins.
- This parameter is determined by device characterization but is not production tested.

### Power Supply Characteristics

Parameters	Description	Test Conditions(1)	Min.	Typ(2)	Max.	Units
$I_{CC}$	Quiescent Power	$V_{CC} = \text{Max.}, V_{IN} = \text{GND or } V_{CC}$	–	0.1	3.0	$\mu\text{A}$
$\Delta I_{CC}$	Supply Current per	$V_{CC} = \text{Max.}, V_{IN} = 3.0\text{V}(3)$	–	–	750	$\mu\text{A}$

**Notes:**

1. For Max. or Min. conditons, use appropriate value specified under Electrical Characteristics for the applicable device.
2. Typical values are at  $V_{CC} = 3.3\text{V}, +25^\circ\text{C}$  ambient.
3. Per TTL driven input (control inputs only); A and B pins do not contribute to  $I_{CC}$ .
4. This current applies to the control inputs only and represent the current required to switch internal capacitance at the specified frequency. The A and B inputs generate no significant AC or DC currents as they transition. This parameter is not tested, but is guaranteed by design.

### PI3B32X384 Switching Characteristics over Operating Range

Parameters	Description	Conditions <sup>(2,3)</sup>	PI3B32x384		Units
			Com.		
			Min.	Max.	
$t_{PLH}$ $t_{PHL}$	Propagation Delay <sup>(2,3)</sup> Ax to Bx, Bx to Ax	$C_L = 50\text{pF}, R_L = 500\Omega$		0.25	ns
$t_{PZH}$ $t_{PZL}$	Bus Enable Time BE to Ax or Bx	$C_L = 50\text{pF}, R_L = 500\Omega$	1.0	4.0	
$t_{PHZ}$ $t_{PLZ}$	Bus Disable Time BE to Ax or Bx	$R = 500\Omega$	1.0	3.5	

**Notes:**

1. See test circuit and waveforms.
2. This parameter is guaranteed but not tested on Propagation Delays.
3. The bus switch contributes no propagational delay other than the RC delay of the ON resistance of the switch and the load capacitance. The time constant for the switch alone is of the order of 0.25ns for 50pF load. Since this time constant is much smaller than the rise/fall times of typical driving signals, it adds very little propagational delay to the system. Propagational delay of the bus switch when used in a system is determined by the driving circuit on the driving side of the switch and its interaction with the load on the driven side.

### Applications Information

#### Logic Inputs

The logic control inputs can be driven up to +3.6V regardless of the supply voltage. For example, given a +3.3V supply, IN may be driven low to 0V and high to 3.6V. Driving IN Rail-to-Rail® minimizes power consumption.

#### Power-Supply Sequencing and Hot Plug Information

Proper power-supply sequencing is recommended for all CMOS devices. Always apply  $V_{CC}$  and GND before applying signals to input/output or control pins.

*Rail-to-Rail is a registered trademark of Nippon Motorola, Ltd*

**Packaging Mechanical: 48-Pin BQSOP (B)**

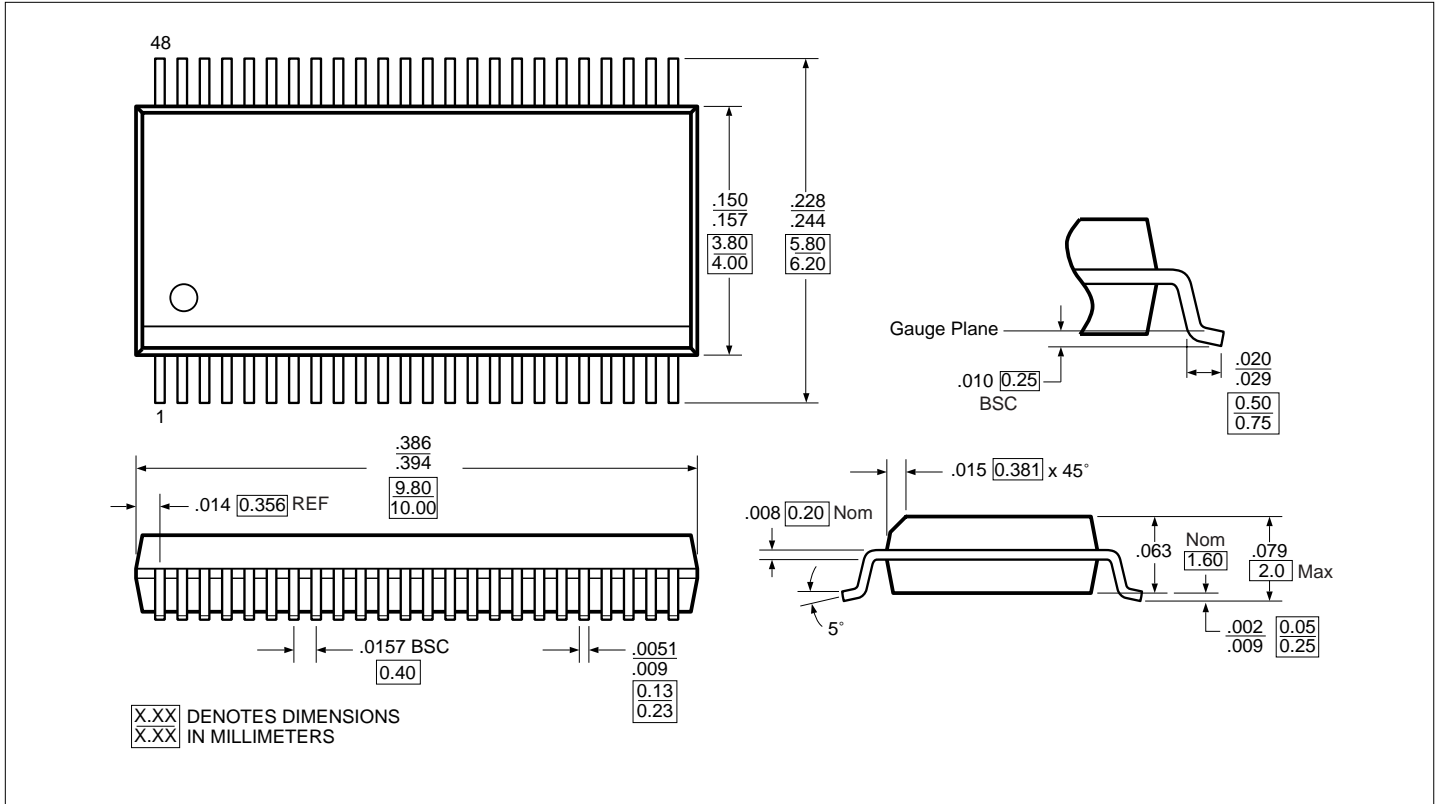

**Ordering Information**

Ordering Code	Package Code	Package Type
PI3B32X384B	B	48-pin BQSOP
PI3B32X384BE	B	Pb-free & Green, 48-pin BQSOP

**Notes:**

1. Thermal characteristics can be found on the company web site at [www.pericom.com/packaging/](http://www.pericom.com/packaging/)