

DATA SHEET

TDA7056B

**5 W mono BTL audio amplifier with
DC volume control**

Product specification
Supersedes data of 1996 May 28
File under Integrated Circuits, IC01

1997 Aug 15

5 W mono BTL audio amplifier with DC volume control

TDA7056B

FEATURES

- DC volume control
- Few external components
- Mute mode
- Thermal protection
- Short-circuit proof
- No switch-on and switch-off clicks
- Good overall stability
- Low power consumption
- Low HF radiation
- ESD protected on all pins.

GENERAL DESCRIPTION

The TDA7056B is a mono Bridge-Tied Load (BTL) output amplifier with DC volume control.

It is designed for use in TV and monitors, but is also suitable for battery-fed portable recorders and radios. The device is contained in a 9-pin medium power package.

A Missing Current Limiter (MCL) is built in. The MCL circuit is activated when the difference in current between the output terminal of each amplifier exceeds 100 mA (300 mA typ.). This level of 100 mA allows for headphone applications (single-ended).

QUICK REFERENCE DATA

SYMBOL	PARAMETER	CONDITIONS	MIN.	TYP.	MAX.	UNIT
V_P	supply voltage		4.5	–	18	V
P_O	output power	$V_P = 12\text{ V}$ $R_L = 16\ \Omega$ $R_L = 8\ \Omega$	3 5	3.5 5.5	– –	W W
$G_{V(\max)}$	maximum total voltage gain		39.5	40.5	41.5	dB
ϕ	gain control		68	73.5	–	dB
$I_{q(\text{tot})}$	total quiescent current	$V_P = 12\text{ V}; R_L = \infty$	–	9.2	13	mA
THD	total harmonic distortion	$P_O = 0.5\text{ W}$	–	0.3	1	%

ORDERING INFORMATION

TYPE NUMBER	PACKAGE		
	NAME	DESCRIPTION	VERSION
TDA7056B	SIL9MPF	plastic single in-line medium power package with fin; 9 leads	SOT110-1

5 W mono BTL audio amplifier with DC volume control

TDA7056B

BLOCK DIAGRAM

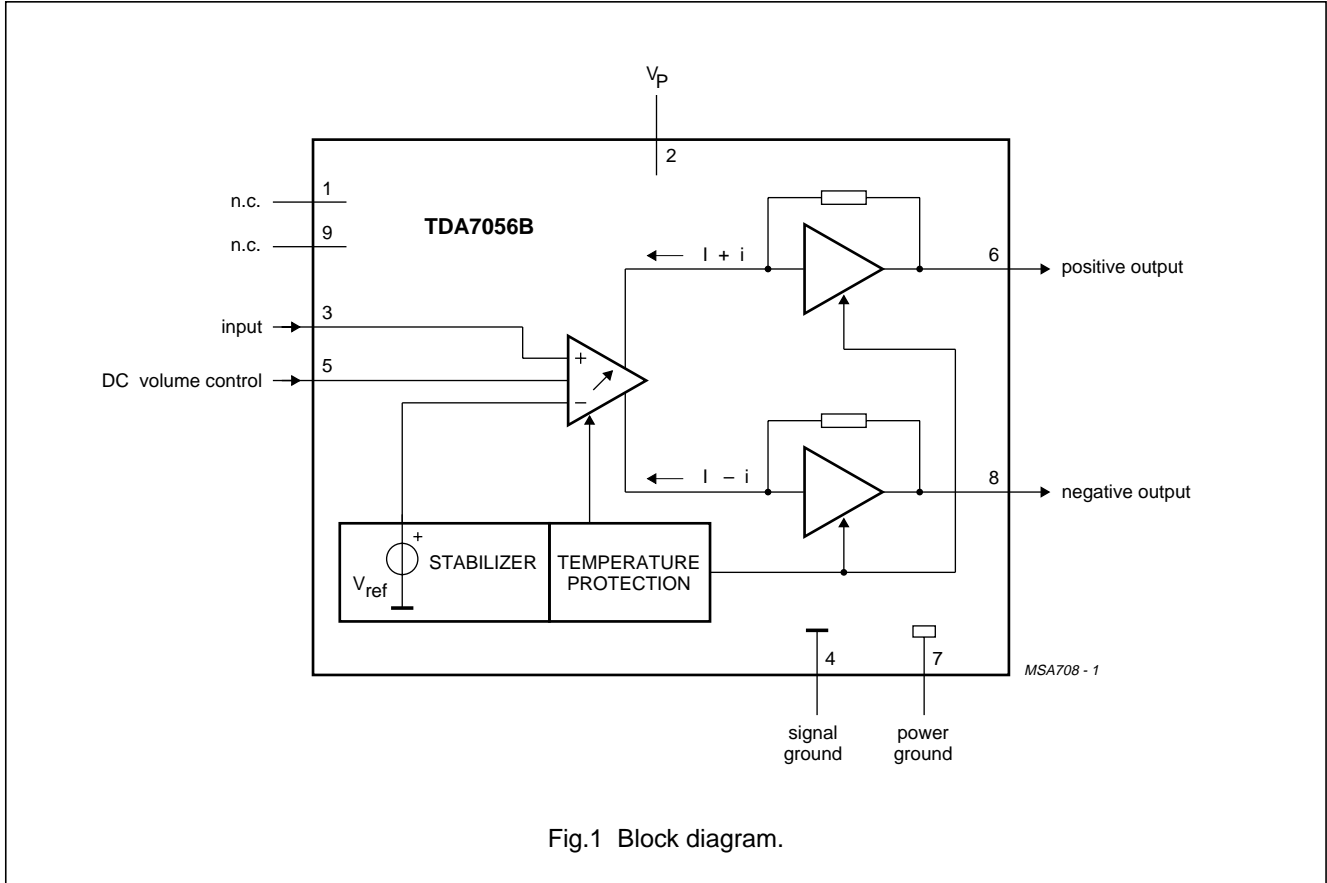

Fig.1 Block diagram.

PINNING

SYMBOL	PIN	DESCRIPTION
n.c.	1	not connected
V_P	2	positive supply voltage
V_I	3	voltage input
GND1	4	signal ground
VC	5	DC volume control
OUT+	6	positive output
GND2	7	power ground
OUT-	8	negative output
n.c.	9	not connected

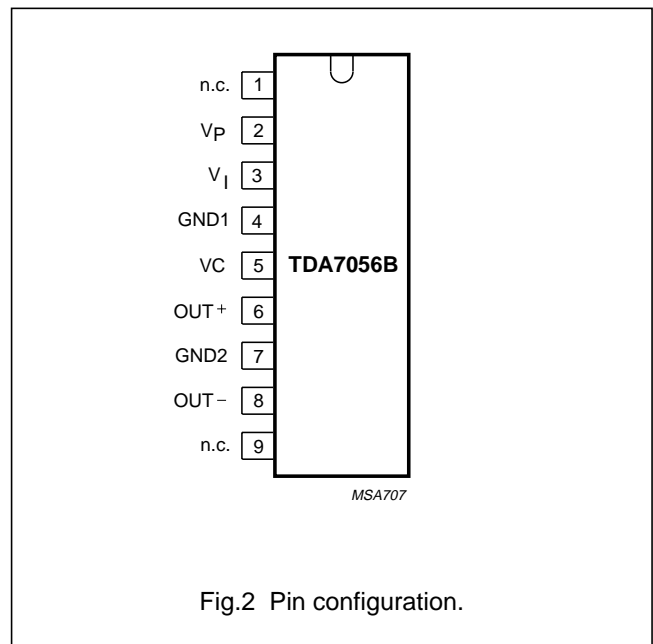

Fig.2 Pin configuration.

5 W mono BTL audio amplifier with DC volume control

TDA7056B

FUNCTIONAL DESCRIPTION

The TDA7056B is a mono BTL output amplifier with DC volume control, designed for use in TV and monitor but is also suitable for battery-fed portable recorders and radios.

In conventional DC volume circuits the control or input stage is AC coupled to the output stage via external capacitors to keep the offset voltage low. In the TDA7056B the DC volume control stage is integrated into the input stage so that no coupling capacitors are required. With this configuration, a low offset voltage is still maintained and the minimum supply voltage remains low.

The BTL principle offers the following advantages:

- Lower peak value of the supply current
- The frequency of the ripple on the supply voltage is twice the signal frequency.

Consequently, a reduced power supply with smaller capacitors can be used which results in cost reductions. For portable applications there is a trend to decrease the supply voltage, resulting in a reduction of output power at conventional output stages. Using the BTL principle increases the output power.

The maximum gain of the amplifier is fixed at 40.5 dB. The DC volume control stage has a logarithmic control characteristic. Therefore, the total gain can be controlled from 40.5 dB to -33 dB. If the DC volume control voltage falls below 0.4 V, the device will switch to the mute mode.

The amplifier is short-circuit proof to ground, V_P and across the load. Also a thermal protection circuit is implemented. If the crystal temperature rises above +150 °C the gain will be reduced, thereby reducing the output power. Special attention is given to switch-on and switch-off clicks, low HF radiation and a good overall stability.

Power dissipation

Assume $V_P = 12$ V; $R_L = 16$ Ω.

The maximum sine wave dissipation is = 1.8 W.

The $R_{th\ j-a}$ of the package is 55 K/W.

Therefore $T_{amb\ (max)} = 150 - 55 \times 1.8 = 51$ °C.

LIMITING VALUES

In accordance with the Absolute Maximum Rating System (IEC 134).

SYMBOL	PARAMETER	CONDITIONS	MIN.	MAX.	UNIT
V_P	supply voltage		-	18	V
$V_{3,5}$	input voltage pins 3 and 5		-	5	V
I_{ORM}	repetitive peak output current		-	1.25	A
I_{OSM}	non-repetitive peak output current		-	1.5	A
P_{tot}	total power dissipation	$T_{case} < 60$ °C	-	9	W
T_{amb}	operating ambient temperature		-40	+85	°C
T_{stg}	storage temperature		-55	+150	°C
T_{vj}	virtual junction temperature		-	+150	°C
T_{sc}	short-circuit time		-	1	h

THERMAL CHARACTERISTICS

SYMBOL	PARAMETER	VALUE	UNIT
$R_{th\ j-a}$	thermal resistance from junction to ambient in free air	55	K/W
$R_{th\ j-c}$	thermal resistance from junction to case	10	K/W

5 W mono BTL audio amplifier with DC volume control

TDA7056B

CHARACTERISTICS

$V_P = 12\text{ V}$; $V_{DC} = 1.4\text{ V}$; $f = 1\text{ kHz}$; $R_L = 16\ \Omega$; $T_{amb} = 25\text{ }^\circ\text{C}$; unless otherwise specified (see Fig.13).

SYMBOL	PARAMETER	CONDITIONS	MIN.	TYP.	MAX.	UNIT
Supply						
V_P	positive supply voltage		4.5	–	18	V
$I_{q(\text{tot})}$	total quiescent current	note 1; $R_L = \infty$	–	9.2	13	mA
Maximum gain ($V_5 = 1.4\text{ V}$)						
P_O	output power	THD = 10%; $R_L = 16\ \Omega$	3	3.5	–	W
		THD = 10%; $R_L = 8\ \Omega$	5	5.5	–	W
THD	total harmonic distortion	$P_O = 0.5\text{ W}$	–	0.3	1	%
$G_{V(\text{max})}$	maximum total voltage gain		39.5	40.5	41.5	dB
V_I	input signal handling (RMS value)	$G_{V(\text{max})} = 0\text{ dB}$; THD < 1%	1.0	–	–	V
V_{no}	noise output voltage (RMS value)	note 2; $f = 500\text{ kHz}$	–	210	–	μV
B	bandwidth	at –1 dB	–	0.02 to 300	–	kHz
SVRR	supply voltage ripple rejection	note 3	34	38	–	dB
$ \Delta V_O $	DC output offset voltage	$ V_8 - v_6 $	–	0	200	mV
Z_I	input impedance (pin 3)		15	20	25	$\text{k}\Omega$
Mute position						
V_O	output voltage in mute position	note 4; $V_5 \leq 0.4\text{ V}$; $V_I = 1.0\text{ V}$	–	35	45	μV
DC volume control; note 5						
ϕ	gain control		68	73.5	–	dB
I_5	control current	$V_5 = 0\text{ V}$	–20	–25	–30	μA

Notes

1. With a load connected to the outputs the quiescent current will increase, the maximum value of this increase being equal to the DC output offset voltage divided by R_L .
2. The noise output voltage (RMS value) at $f = 500\text{ kHz}$ is measured with $R_S = 0\ \Omega$ and $B = 5\text{ kHz}$.
3. The ripple rejection is measured with $R_S = 0\ \Omega$ and $f = 100\text{ Hz}$ to 10 kHz . The ripple voltage V_R of 200 mV (RMS value) is applied to the positive supply rail.
4. The noise output voltage (RMS value) is measured with $R_S = 5\text{ k}\Omega$ unweighted.
5. The DC volume control can be configured in several ways. Two possible circuits are shown in Figs 14 and 15. The circuits at the volume control pin will influence the switch-on and switch-off behaviour and the maximum voltage gain.

5 W mono BTL audio amplifier with DC volume control

TDA7056B

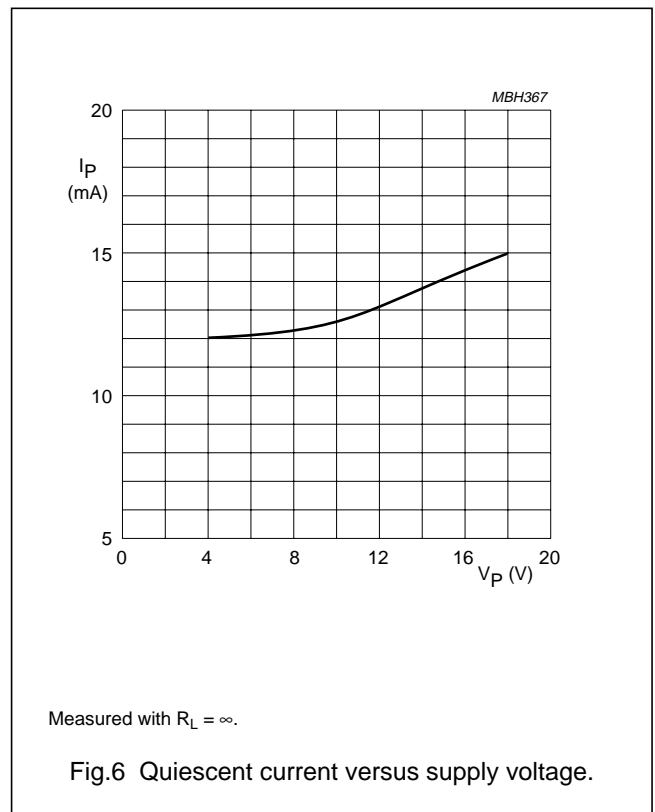
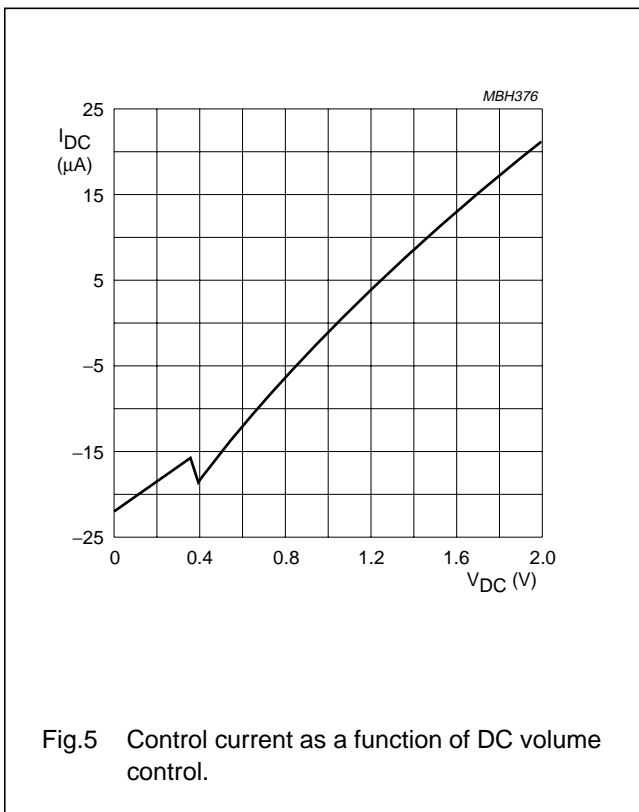
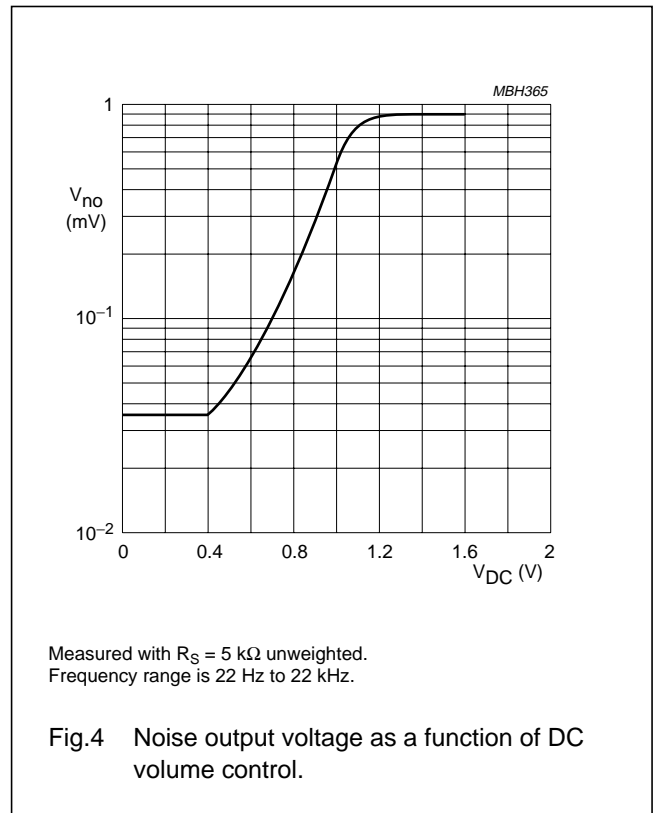
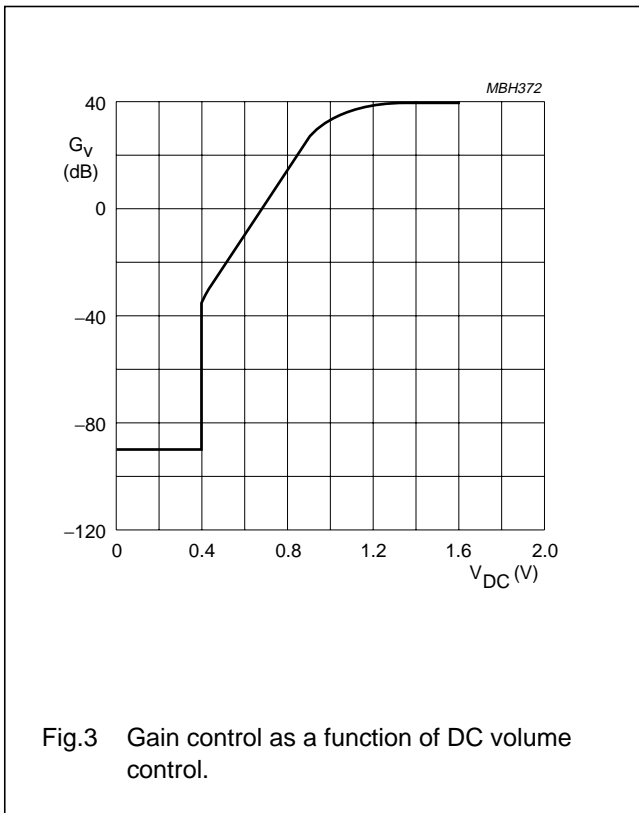

5 W mono BTL audio amplifier with DC volume control

TDA7056B

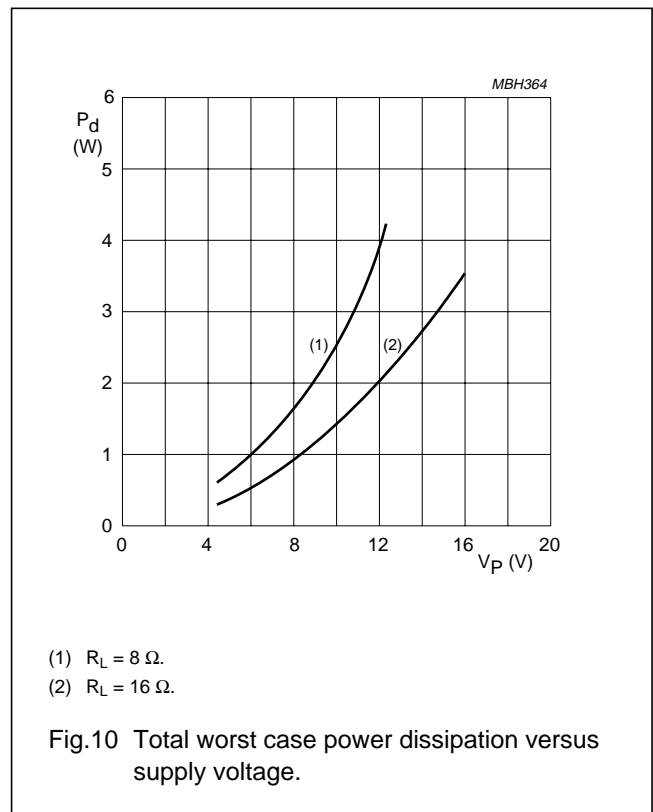
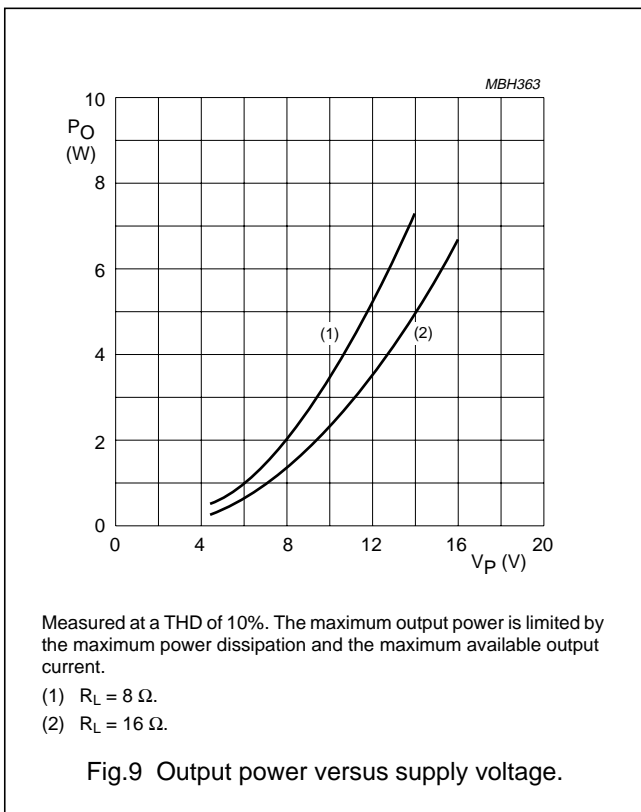
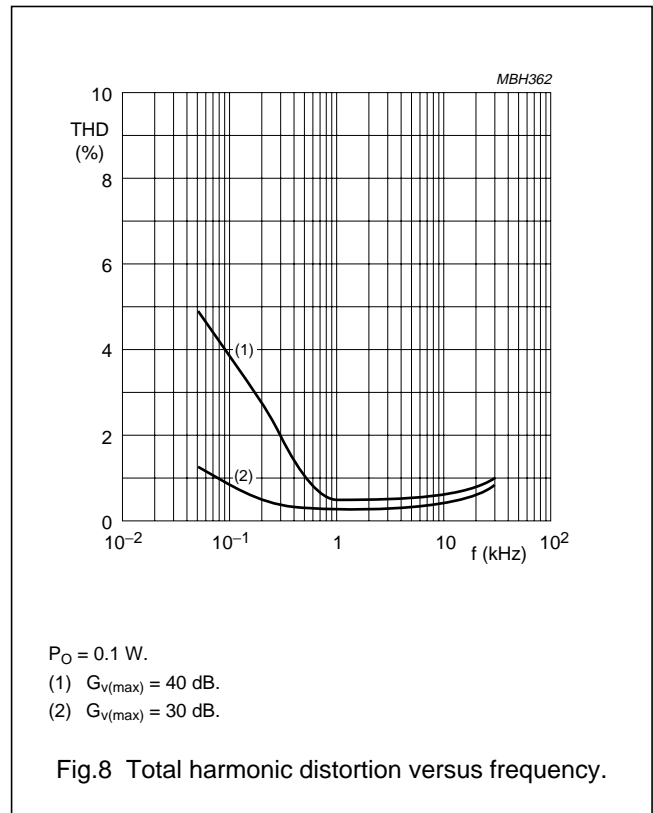
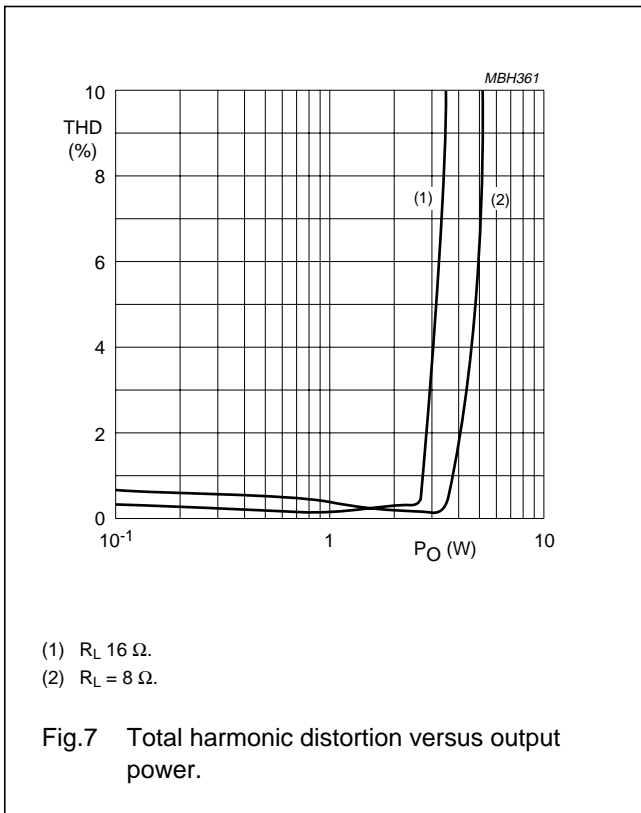

5 W mono BTL audio amplifier with DC volume control

TDA7056B

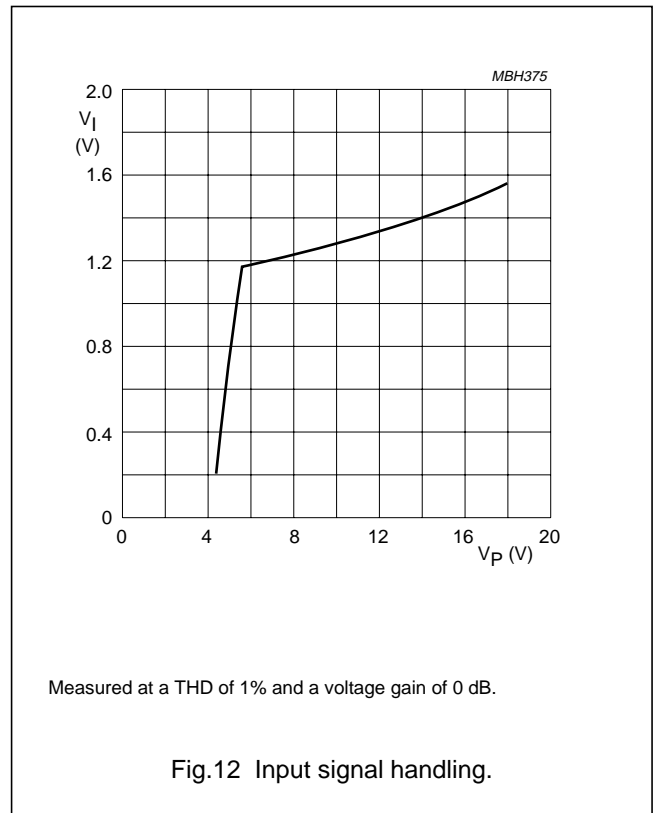
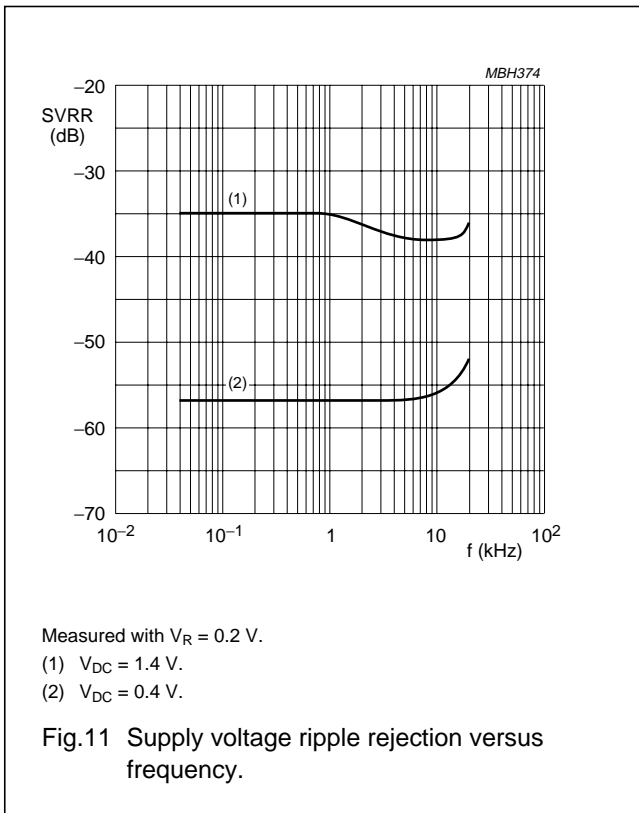

5 W mono BTL audio amplifier with DC volume control

TDA7056B

TEST AND APPLICATION INFORMATION

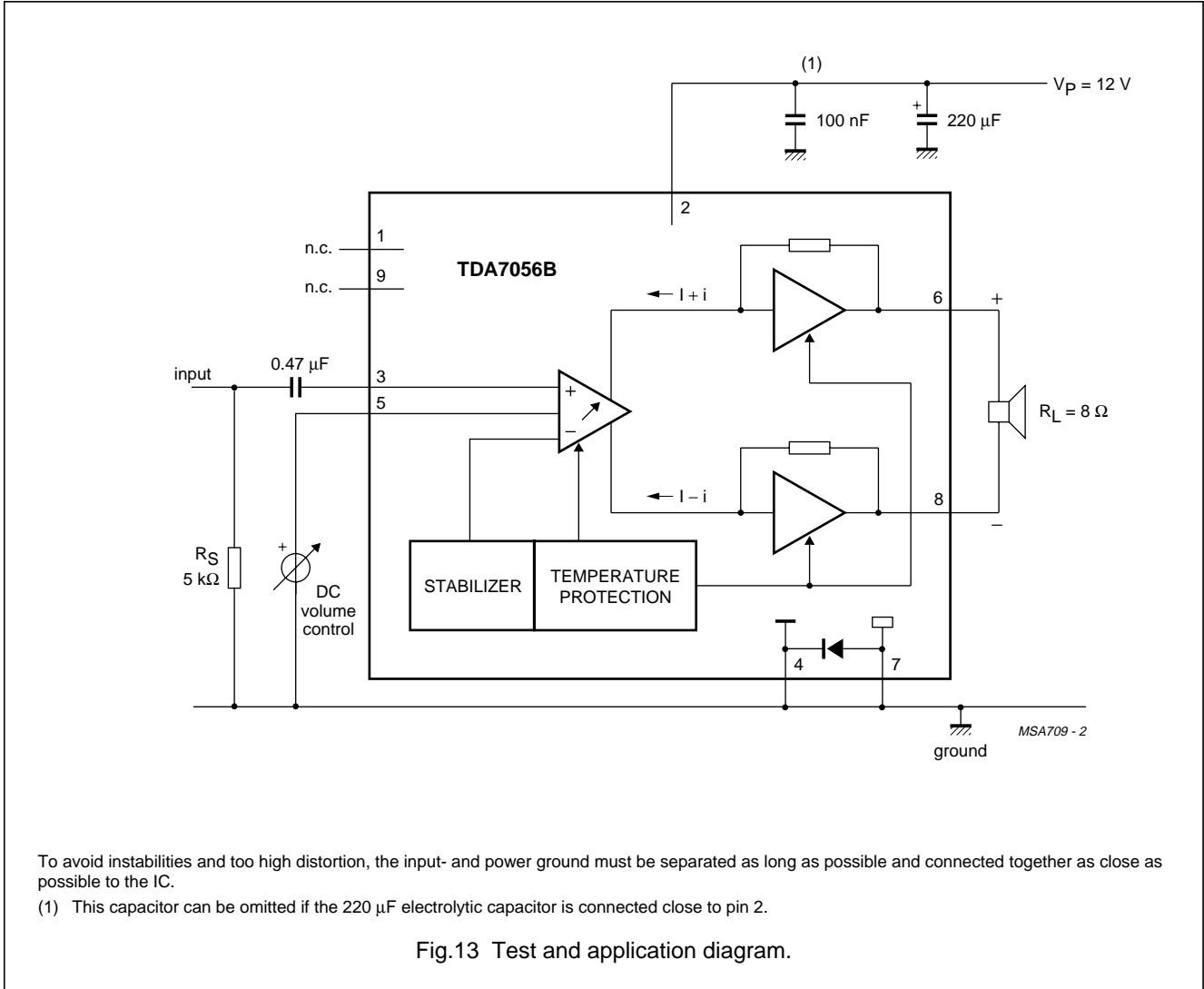

For single-end application the output peak current may not exceed 100 mA; at higher output currents the short circuit protection (MLC) will be activated.

5 W mono BTL audio amplifier with DC volume control

TDA7056B

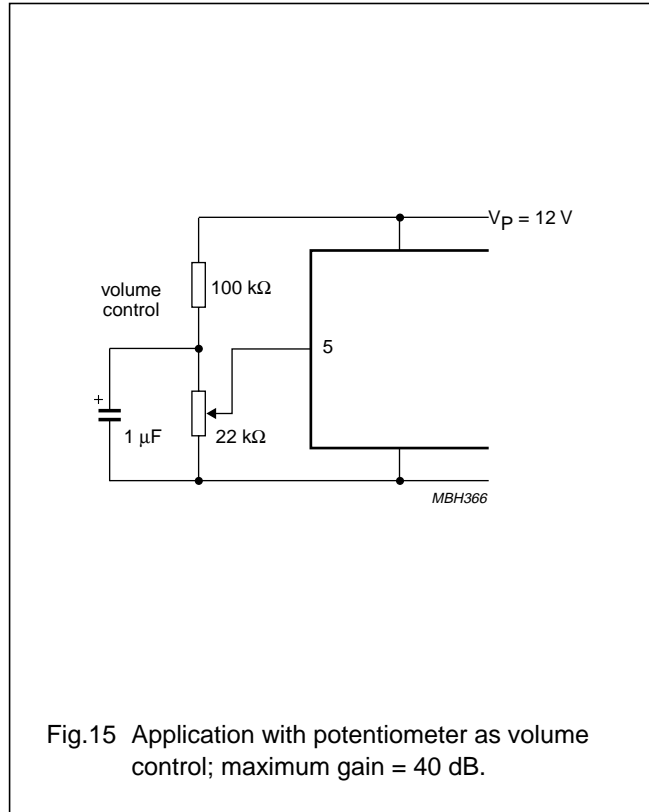
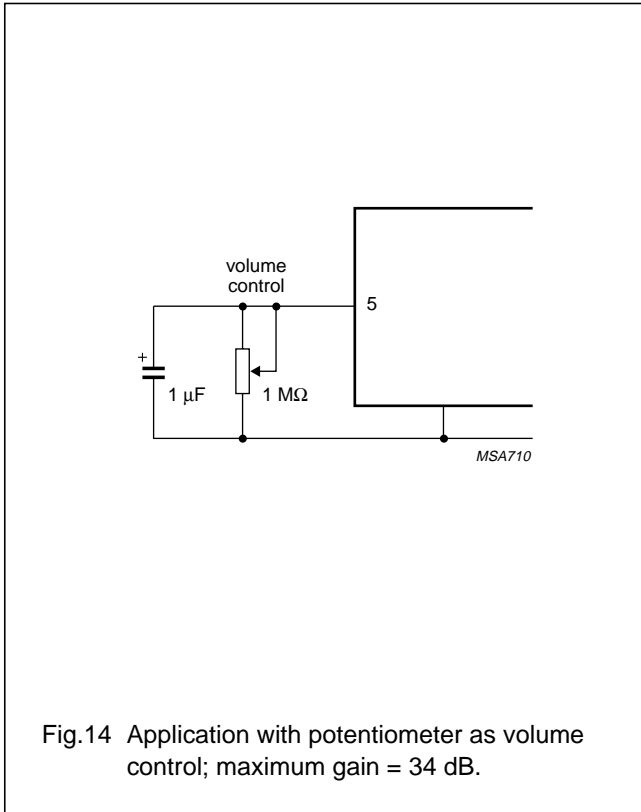

5 W mono BTL audio amplifier with DC volume control

TDA7056B

PACKAGE OUTLINE

SIL9MPF: plastic single in-line medium power package with fin; 9 leads

SOT110-1

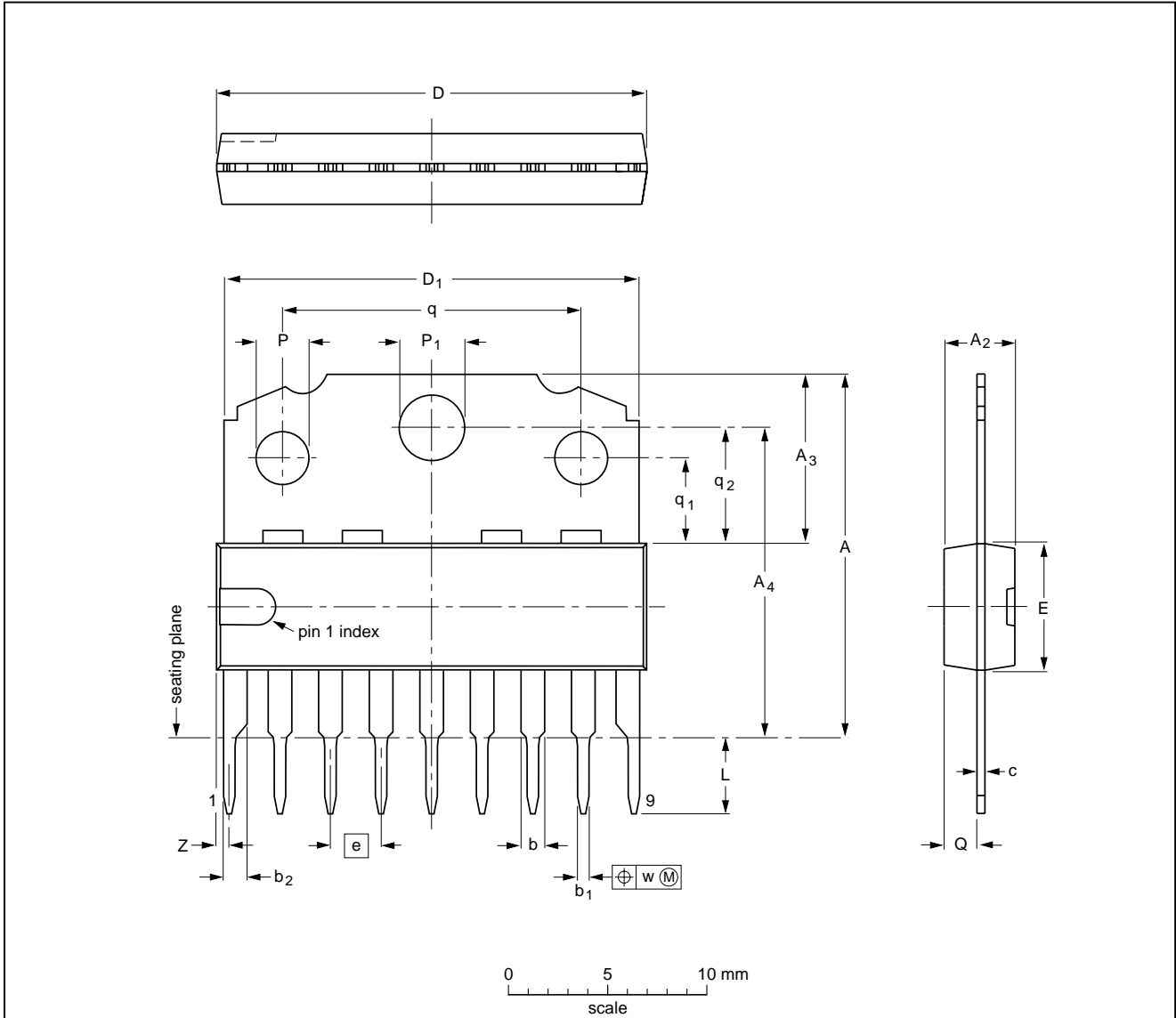

DIMENSIONS (mm are the original dimensions)

UNIT	A	A ₂ max.	A ₃	A ₄	b	b ₁	b ₂	c	D ⁽¹⁾	D ₁	E ⁽¹⁾	e	L	P	P ₁	Q	q	q ₁	q ₂	w	Z ⁽¹⁾ max.
mm	18.5 17.8	3.7	8.7 8.0	15.8 15.4	1.40 1.14	0.67 0.50	1.40 1.14	0.48 0.38	21.8 21.4	21.4 20.7	6.48 6.20	2.54	3.9 3.4	2.75 2.50	3.4 3.2	1.75 1.55	15.1 14.9	4.4 4.2	5.9 5.7	0.25	1.0

Note

1. Plastic or metal protrusions of 0.25 mm maximum per side are not included.

OUTLINE VERSION	REFERENCES				EUROPEAN PROJECTION	ISSUE DATE
	IEC	JEDEC	EIAJ			
SOT110-1						92-11-17 95-02-25

5 W mono BTL audio amplifier with DC volume control

TDA7056B

SOLDERING

Introduction

There is no soldering method that is ideal for all IC packages. Wave soldering is often preferred when through-hole and surface mounted components are mixed on one printed-circuit board. However, wave soldering is not always suitable for surface mounted ICs, or for printed-circuits with high population densities. In these situations reflow soldering is often used.

This text gives a very brief insight to a complex technology. A more in-depth account of soldering ICs can be found in our "IC Package Databook" (order code 9398 652 90011).

Soldering by dipping or by wave

The maximum permissible temperature of the solder is 260 °C; solder at this temperature must not be in contact with the joint for more than 5 seconds. The total contact time of successive solder waves must not exceed 5 seconds.

The device may be mounted up to the seating plane, but the temperature of the plastic body must not exceed the specified maximum storage temperature ($T_{stg\ max}$). If the printed-circuit board has been pre-heated, forced cooling may be necessary immediately after soldering to keep the temperature within the permissible limit.

Repairing soldered joints

Apply a low voltage soldering iron (less than 24 V) to the lead(s) of the package, below the seating plane or not more than 2 mm above it. If the temperature of the soldering iron bit is less than 300 °C it may remain in contact for up to 10 seconds. If the bit temperature is between 300 and 400 °C, contact may be up to 5 seconds.

DEFINITIONS

Data sheet status	
Objective specification	This data sheet contains target or goal specifications for product development.
Preliminary specification	This data sheet contains preliminary data; supplementary data may be published later.
Product specification	This data sheet contains final product specifications.
Limiting values	
Limiting values given are in accordance with the Absolute Maximum Rating System (IEC 134). Stress above one or more of the limiting values may cause permanent damage to the device. These are stress ratings only and operation of the device at these or at any other conditions above those given in the Characteristics sections of the specification is not implied. Exposure to limiting values for extended periods may affect device reliability.	
Application information	
Where application information is given, it is advisory and does not form part of the specification.	

LIFE SUPPORT APPLICATIONS

These products are not designed for use in life support appliances, devices, or systems where malfunction of these products can reasonably be expected to result in personal injury. Philips customers using or selling these products for use in such applications do so at their own risk and agree to fully indemnify Philips for any damages resulting from such improper use or sale.

5 W mono BTL audio amplifier with DC
volume control

TDA7056B

NOTES

5 W mono BTL audio amplifier with DC
volume control

TDA7056B

NOTES

5 W mono BTL audio amplifier with DC
volume control

TDA7056B

NOTES

Philips Semiconductors – a worldwide company

Argentina: see South America

Australia: 34 Waterloo Road, NORTH RYDE, NSW 2113,
Tel. +61 2 9805 4455, Fax. +61 2 9805 4466

Austria: Computerstr. 6, A-1101 WIEN, P.O. Box 213, Tel. +43 160 1010,
Fax. +43 160 101 1210

Belarus: Hotel Minsk Business Center, Bld. 3, r. 1211, Volodarski Str. 6,
220050 MINSK, Tel. +375 172 200 733, Fax. +375 172 200 773

Belgium: see The Netherlands

Brazil: see South America

Bulgaria: Philips Bulgaria Ltd., Energoproject, 15th floor,
51 James Bourchier Blvd., 1407 SOFIA,
Tel. +359 2 689 211, Fax. +359 2 689 102

Canada: PHILIPS SEMICONDUCTORS/COMPONENTS,
Tel. +1 800 234 7381

China/Hong Kong: 501 Hong Kong Industrial Technology Centre,
72 Tat Chee Avenue, Kowloon Tong, HONG KONG,
Tel. +852 2319 7888, Fax. +852 2319 7700

Colombia: see South America

Czech Republic: see Austria

Denmark: Prags Boulevard 80, PB 1919, DK-2300 COPENHAGEN S,
Tel. +45 32 88 2636, Fax. +45 31 57 0044

Finland: Sinikalliontie 3, FIN-02630 ESPOO,
Tel. +358 9 615800, Fax. +358 9 61580920

France: 4 Rue du Port-aux-Vins, BP317, 92156 SURESNES Cedex,
Tel. +33 1 40 99 6161, Fax. +33 1 40 99 6427

Germany: Hammerbrookstraße 69, D-20097 HAMBURG,
Tel. +49 40 23 53 60, Fax. +49 40 23 536 300

Greece: No. 15, 25th March Street, GR 17778 TAVROS/ATHENS,
Tel. +30 1 4894 339/239, Fax. +30 1 4814 240

Hungary: see Austria

India: Philips INDIA Ltd, Band Box Building, 2nd floor,
254-D, Dr. Annie Besant Road, Worli, MUMBAI 400 025,
Tel. +91 22 493 8541, Fax. +91 22 493 0966

Indonesia: see Singapore

Ireland: Newstead, Clonskeagh, DUBLIN 14,
Tel. +353 1 7640 000, Fax. +353 1 7640 200

Israel: RAPAC Electronics, 7 Kehilat Saloniki St, PO Box 18053,
TEL AVIV 61180, Tel. +972 3 645 0444, Fax. +972 3 649 1007

Italy: PHILIPS SEMICONDUCTORS, Piazza IV Novembre 3,
20124 MILANO, Tel. +39 2 6752 2531, Fax. +39 2 6752 2557

Japan: Philips Bldg 13-37, Kohnan 2-chome, Minato-ku, TOKYO 108,
Tel. +81 3 3740 5130, Fax. +81 3 3740 5077

Korea: Philips House, 260-199 Itaewon-dong, Yongsan-ku, SEOUL,
Tel. +82 2 709 1412, Fax. +82 2 709 1415

Malaysia: No. 76 Jalan Universiti, 46200 PETALING JAYA, SELANGOR,
Tel. +60 3 750 5214, Fax. +60 3 757 4880

Mexico: 5900 Gateway East, Suite 200, EL PASO, TEXAS 79905,
Tel. +9-5 800 234 7381

Middle East: see Italy

Netherlands: Postbus 90050, 5600 PB EINDHOVEN, Bldg. VB,
Tel. +31 40 27 82785, Fax. +31 40 27 88399

New Zealand: 2 Wagener Place, C.P.O. Box 1041, AUCKLAND,
Tel. +64 9 849 4160, Fax. +64 9 849 7811

Norway: Box 1, Manglerud 0612, OSLO,
Tel. +47 22 74 8000, Fax. +47 22 74 8341

Philippines: Philips Semiconductors Philippines Inc.,
106 Valero St. Salcedo Village, P.O. Box 2108 MCC, MAKATI,
Metro MANILA, Tel. +63 2 816 6380, Fax. +63 2 817 3474

Poland: Ul. Lukiska 10, PL 04-123 WARSZAWA,
Tel. +48 22 612 2831, Fax. +48 22 612 2327

Portugal: see Spain

Romania: see Italy

Russia: Philips Russia, Ul. Usatcheva 35A, 119048 MOSCOW,
Tel. +7 095 755 6918, Fax. +7 095 755 6919

Singapore: Lorong 1, Toa Payoh, SINGAPORE 1231,
Tel. +65 350 2538, Fax. +65 251 6500

Slovakia: see Austria

Slovenia: see Italy

South Africa: S.A. PHILIPS Pty Ltd., 195-215 Main Road Martindale,
2092 JOHANNESBURG, P.O. Box 7430 Johannesburg 2000,
Tel. +27 11 470 5911, Fax. +27 11 470 5494

South America: Rua do Rocio 220, 5th floor, Suite 51,
04552-903 São Paulo, SÃO PAULO - SP, Brazil,
Tel. +55 11 821 2333, Fax. +55 11 829 1849

Spain: Balmes 22, 08007 BARCELONA,
Tel. +34 3 301 6312, Fax. +34 3 301 4107

Sweden: Kottbygatan 7, Akalla, S-16485 STOCKHOLM,
Tel. +46 8 632 2000, Fax. +46 8 632 2745

Switzerland: Allmendstrasse 140, CH-8027 ZÜRICH,
Tel. +41 1 488 2686, Fax. +41 1 481 7730

Taiwan: Philips Semiconductors, 6F, No. 96, Chien Kuo N. Rd., Sec. 1,
TAIPEI, Taiwan Tel. +886 2 2134 2865, Fax. +886 2 2134 2874

Thailand: PHILIPS ELECTRONICS (THAILAND) Ltd.,
209/2 Sanpavuth-Bangna Road Prakanong, BANGKOK 10260,
Tel. +66 2 745 4090, Fax. +66 2 398 0793

Turkey: Talatpasa Cad. No. 5, 80640 GÜLTEPE/ISTANBUL,
Tel. +90 212 279 2770, Fax. +90 212 282 6707

Ukraine: PHILIPS UKRAINE, 4 Patrice Lumumba str., Building B, Floor 7,
252042 KIEV, Tel. +380 44 264 2776, Fax. +380 44 268 0461

United Kingdom: Philips Semiconductors Ltd., 276 Bath Road, Hayes,
MIDDLESEX UB3 5BX, Tel. +44 181 730 5000, Fax. +44 181 754 8421

United States: 811 East Arques Avenue, SUNNYVALE, CA 94088-3409,
Tel. +1 800 234 7381

Uruguay: see South America

Vietnam: see Singapore

Yugoslavia: PHILIPS, Trg N. Pasica 5/v, 11000 BEOGRAD,
Tel. +381 11 625 344, Fax. +381 11 635 777

For all other countries apply to: Philips Semiconductors, Marketing & Sales Communications,
Building BE-p, P.O. Box 218, 5600 MD EINDHOVEN, The Netherlands, Fax. +31 40 27 24825

Internet: <http://www.semiconductors.philips.com>

© Philips Electronics N.V. 1997

SCA55

All rights are reserved. Reproduction in whole or in part is prohibited without the prior written consent of the copyright owner.

The information presented in this document does not form part of any quotation or contract, is believed to be accurate and reliable and may be changed without notice. No liability will be accepted by the publisher for any consequence of its use. Publication thereof does not convey nor imply any license under patent- or other industrial or intellectual property rights.

Printed in The Netherlands

547027/1200/03/pp16

Date of release: 1997 Aug 15

Document order number: 9397 750 02728

Let's make things better.

Philips
Semiconductors



PHILIPS