

DATA SHEET

UBA2000T Electronic TL-lamp starter

Product specification
File under Integrated Circuits, IC11

1996 Jan 03

Electronic TL-lamp starter

UBA2000T

FEATURES

- Electronic starter, fully compatible with conventional glow-switch starters
- Reliable and instant ignition
- Accurate defined preheat time derived from the mains frequency
- Increased starter life since no mechanical parts are used
- No radio-interference (according to "IEC926 10.5")
- Automatic reset after interruption of supply voltage
- Large operating temperature range: -40 to +85 °C
- Maximum current protection of the preheat current
- Ignition shut-off at end of lamp life; no overheating of load.

GENERAL DESCRIPTION

The UBA2000T is an integrated circuit for electronic TL-lamp starters and is fully compatible with conventional glow switch starters. The circuit controls the preheating and ignition of the lamp. The preheat time is well defined without spread, since it is derived from the mains frequency. When the lamp fails, ignition is shut-off after 7 ignition attempts. The circuit has an automatic reset when the supply voltage is interrupted.

ORDERING INFORMATION

TYPE NUMBER	PACKAGE		
	NAME	DESCRIPTION	VERSION
UBA2000T	SO8	plastic small outline package; 8 leads; body width 3.9 mm	SOT96-1

Electronic TL-lamp starter

UBA2000T

BLOCK DIAGRAM

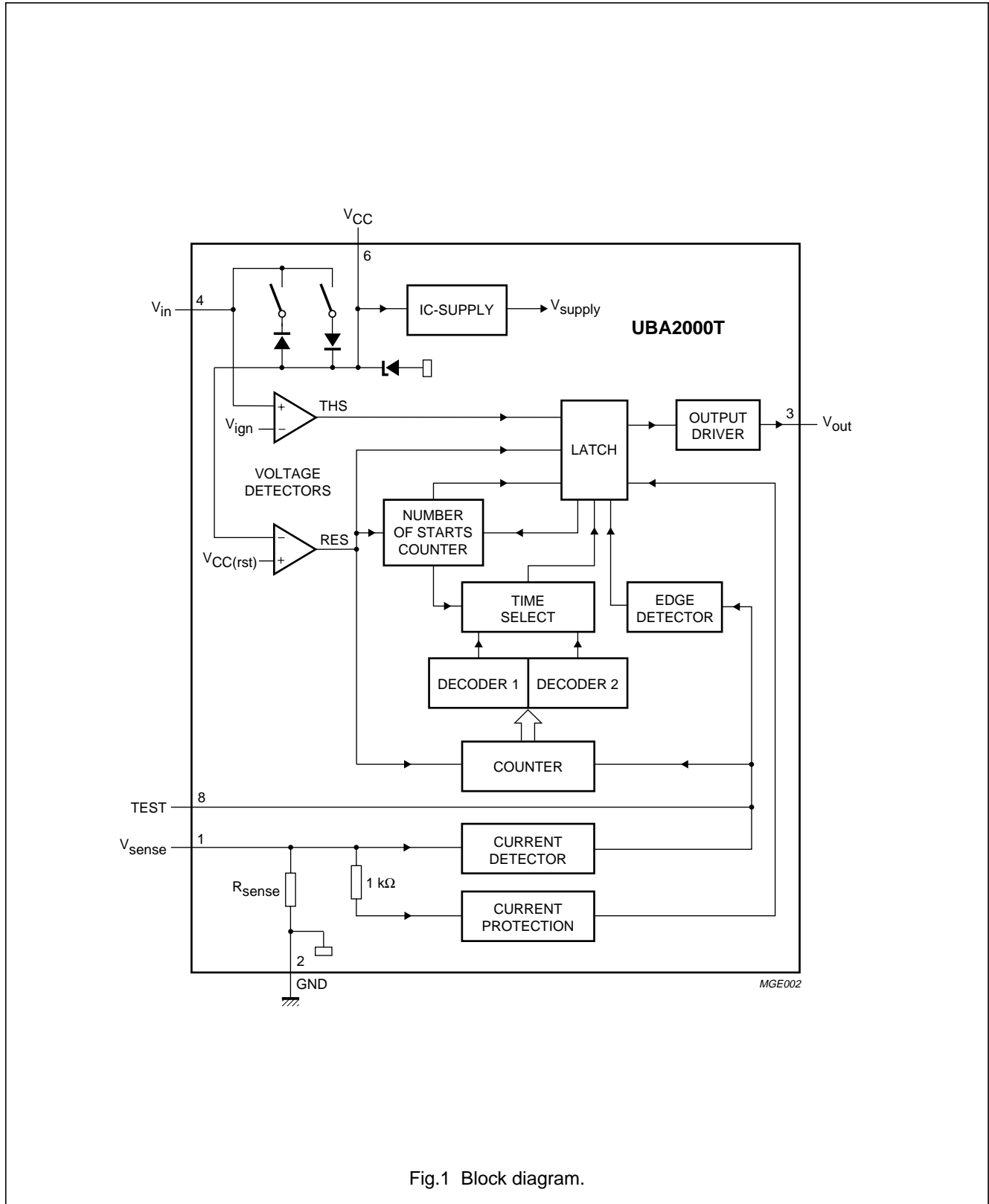

Fig.1 Block diagram.

Electronic TL-lamp starter

UBA2000T

PINNING

SYMBOL	PIN	DESCRIPTION
V_{sense}	1	sense voltage
GND	2	ground (0 V)
V_{out}	3	output voltage
V_{in}	4	input voltage
n.c.	5	not connected
V_{CC}	6	supply voltage
n.c.	7	not connected
TEST	8	test pin

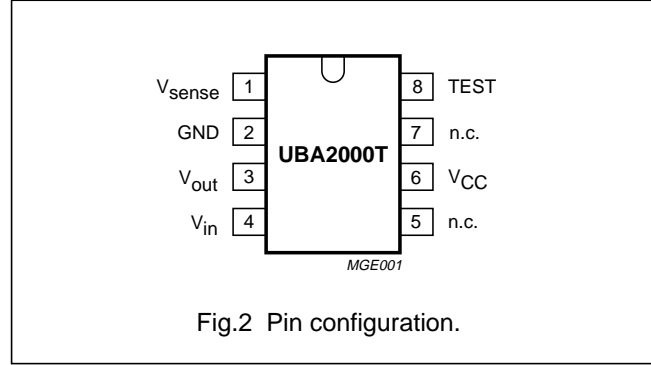

Fig.2 Pin configuration.

FUNCTIONAL DESCRIPTION

The UBA2000T is an Integrated Circuit that performs all functions necessary to ignite a TL-lamp. The circuit is connected to the lamp circuit according to Figs. 7 or 8. The mains voltage is rectified and divided over resistors R1 and R2 to a lower level. When the mains power is switched on, the buffer capacitor C1 is charged through the resistive divider and internal switch S1. As long as the supply voltage at the buffer capacitor (V_{CC} , see "Characteristics") is below the reset level ($V_{CC(rst)}$), the UBA2000T initializes its internal circuitry.

When V_{CC} has reached the start level ($V_{CC(s)}$) and the peak value of $V_{in} > V_{ign}$ (indicating that the mains supply is near its peak value), the external switching device TH1 will be turned on. This results in a current through the electrodes of the TL-lamp, the switching device and an integrated sense resistor. Because the current starts to flow when the mains voltage is near its peak value, transient currents are limited.

When the switching device is turned on, the circuit draws its supply current from buffer capacitor C1. A typical wave shape of the voltage at pin 6 (V_{CC}) is given in Fig.3. During the preheat periods the buffer capacitor is discharged. The rectified current through the sense resistor is detected and the output signal of the detector is used as a clock signal for the counter. The preheat time is defined to 1.52 s (at 50 Hz mains supply) using this counter. The preheat time is very accurate, since it only depends on the frequency of the mains supply.

After preheating, the switching device is turned off when the current through the internal sense resistor equals at least 285 mA. As a result of the current interruption and the presence of an inductive load, a voltage peak is generated that will normally ignite the TL-lamp. After ignition, the lamp voltage is lower than the mains voltage. An ignited TL-lamp prevents the voltage at pin 6 (V_{CC}) to exceed start level. In Fig.3 the TL-lamp is ignited after two ignition attempts.

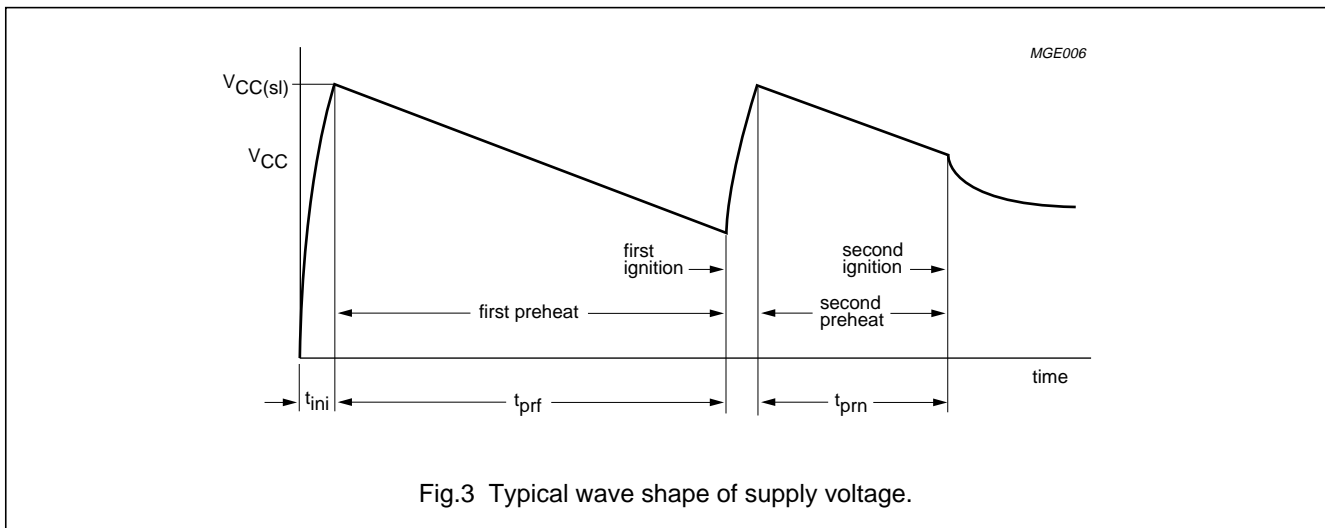

Fig.3 Typical wave shape of supply voltage.

Electronic TL-lamp starter

UBA2000T

During preheating, the integrated circuit draws its supply current from the buffer capacitor. As a result, the voltage over the buffer capacitor decreases. When the ignition has failed after the ignition pulse, the voltage on the buffer capacitor increases to start level and the external switching device will be turned on again. This time the preheat time is reduced to 0.64 seconds because the lamp electrodes are still warm. An internal counter limits the number of ignitions attempts to 7. This prevents the lamp from flickering at end of lamp life.

The UBA2000T has an integrated current protection. When the current through the sense resistor exceeds the protection level (I_{prot}), the switching device is turned off and the circuit will enter a standby state. Switching the mains voltage off and on again will reset the circuit.

The flow chart of the starting process is given in Fig.5. In the following subsections the several blocks of the block diagram are described in more detail.

IC supply

When the mains power is switched on, the buffer capacitor is charged and the internal current source is started. The internal voltage is stabilized, making it independent of the voltage at the buffer capacitor. An internal zener diode limits the voltage at pin 6 (V_{CC}) to start level ($V_{CC(s)}$).

Voltage detectors

The voltage detectors measure the voltage on the buffer capacitor and activate the switching device when the start value ($V_{CC(s)}$) is reached. The time required to charge the capacitor is the initial time (t_{ini} , see also Fig.3).

This time depends on the value of $C1$, the IC current and the source resistance at pin V_{in} ($R1//R2$). When the mains voltage is near its peak value, the switching device is actually turned on. When the voltage decreases to a value indicating that the mains supply is interrupted, the starter is ready to start preheating and igniting the TL-lamp at the moment the mains supply returns.

Latch

The internal state of the latch represents the state of the switching device. The setting of the latch depends on the outputs of the voltage detectors, the number of starts counter and the standby state. Resetting the latch is controlled by the timer, the current detector and the current protection circuit.

Current detector

The current detector detects when the switching device must be turned off. The current detector also generates the clock pulses to activate the counter (see Fig.4). For proper functioning, the preheat current should be within the range indicated by I_{pr} . By including an hysteresis, unwanted current peaks on the preheat current have no effect on the counter. Because the current detector has a low-pass transfer function, it is not influenced by spikes. This circuitry eliminates the effect of spikes on the preheat time.

Edge detector

The edge detector ensures that the switching device will be turned off when the rectified preheat current is on the negative-going edge.

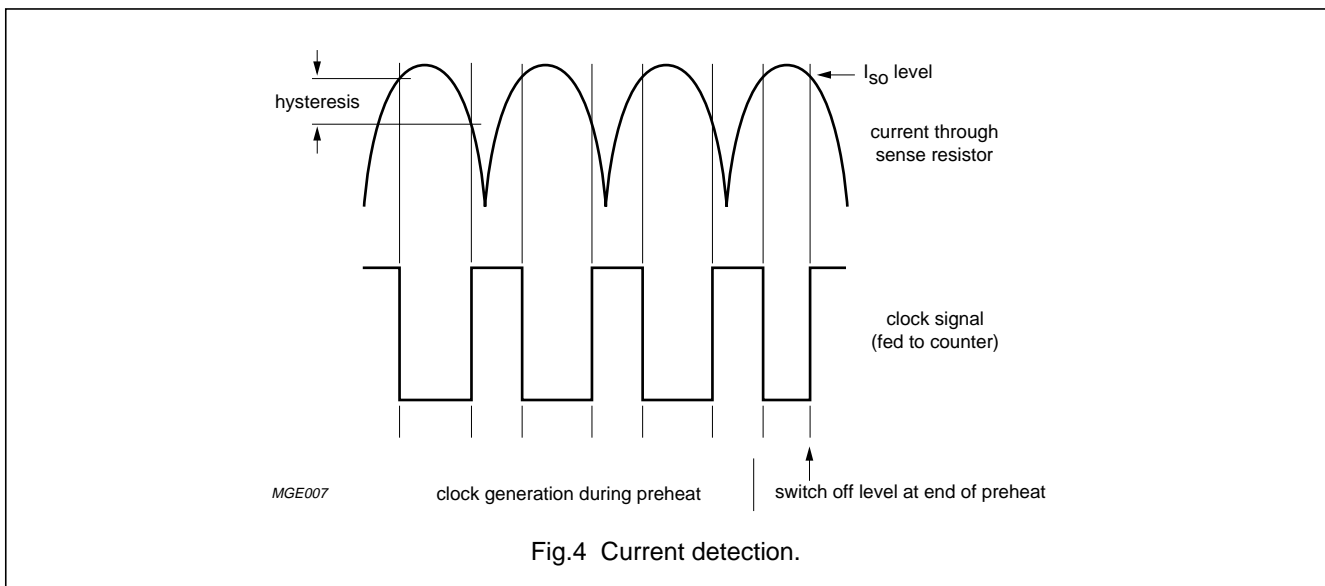

Fig.4 Current detection.

Electronic TL-lamp starter

UBA2000T

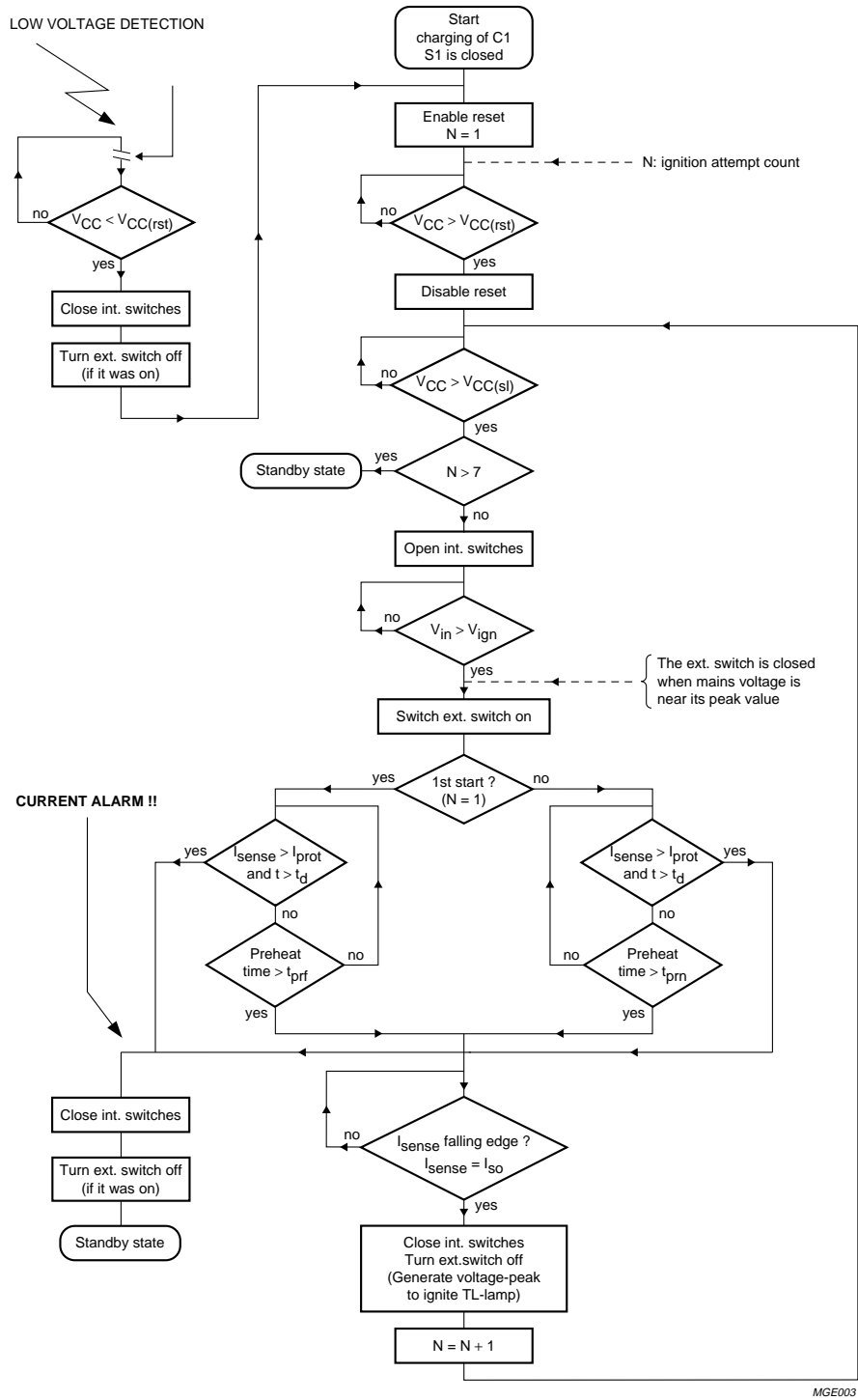

Fig.5 Flow chart.

Electronic TL-lamp starter

UBA2000T

Counter

With the counter, which is supplied with pulses with twice the frequency of the mains supply, the preheat time for the first preheat and (if necessary) the next six preheats is defined.

Time select

Depending on the state of the counter a long ($t_{prf} = 1.52$ s) or a short ($t_{prn} = 0.64$ s) preheat time is selected.

Number of starts counter

The number of starts are counted by a counter. After seven ignition attempts the IC is brought into standby state. In standby state the supply current (I_{CC}) is increased. Due to the increased current, the buffer capacitor C1 will discharge faster when the starter is disconnected from the mains. This makes it possible to automatically reset the starter the moment a malfunctioning tube is replaced by a new one.

Current protection

When the current through the sense resistor exceeds its limit (I_{prot}), the switching device will be turned off. During the first few periods of conduction, the current protection is disabled (disable time t_d) to ensure that transient currents do not trigger the current protection. When the current has exceeded its limit, the switching device is turned off and the IC enters the standby state that prevents re-activating the switching device. Only an interruption of the supply voltage will reset the standby state.

Output driver

The output driver is capable of driving a low input current trigger device as well as a device controlled by a gate. During start-up the output is kept low to prevent turning on the external switching device.

TRIGGER DEVICE

A typical application that uses a low input current trigger device (such as TN22) as switching device is given in Fig.7. The resistive divider R1//R2 is not connected to ground but to the gate of the trigger device.

This has a minimal effect on the voltage division ratio, since the voltage at the gate of the trigger device is low. The output driver generates the current pulse, which is necessary to activate the external switching device TH1. This current pulse is synchronized with the voltage at pin 4 (V_{in}). The switching device is triggered when V_{in} reaches the V_{ign} level. In that way the current through resistors R1 and R2 is a part of the current needed to activate the switching device. If necessary, the current pulse is delivered every half cycle of the mains voltage. When the switching device must be turned off, the output driver is capable of sinking the gate turn-off current of the switching device.

It might be necessary to limit the current peaks, which flow through the switching device at turn-on, resulting from discharging the suppressor capacitor (C2). This can be achieved using a resistor (R3).

GATE INPUT DEVICE

A typical application that uses a MOSFET is given in Fig.8. In this circuit the resistive divider is connected to ground. The output driver of the IC operates the same way as when a trigger device is used. The output current pulse will charge the gate of the MOSFET. As a result, the MOSFET will be activated.

To keep the MOSFET conductive, a high ohmic pull-up resistor is connected between the gate of the MOSFET and the buffer capacitor C1. This is necessary, because the output current is a pulse and not a continuous signal. This pull-up resistor increases the current which is drawn from the buffer capacitor. An internal zener diode in the IC limits the voltage at the output (and thus at the gate of the MOSFET) to a typical value of 6.8 V.

Both switching devices require the breakdown voltage ($V_{(BR)AK}$ or $V_{(BR)DS}$) to be larger than the ignition voltage of the TL-lamp.

Electronic TL-lamp starter

UBA2000T

LIMITING VALUES

In accordance with the Absolute Maximum Rating System (IEC 134).

SYMBOL	PARAMETER	CONDITIONS	MIN.	MAX.	UNIT
V_{out}	output voltage	note 1	–	6	V
V_{in}	input voltage	note 2	–	125	V
V_{TEST}	voltage at test pin		–	6	V
I_{sense}	current through sense resistor	note 3	–	6	A
P_{tot}	total power dissipation		–	395	mW
T_{stg}	storage temperature	non-operating	–55	150	°C
T_{amb}	ambient temperature	operating	–40	85	°C

Notes

- This pin is connected to an internal zener diode (typical working voltage is 6.8 V).
- This pin is connected to an internal zener diode (working voltage between 130 and 230 V).
The current entering this pin must be limited to <10 mA.
- Inrush current, duration <2 ms.

QUALITY SPECIFICATION

In accordance with “SNW-FQ-611-E” with the following exception: With respect to the integrated sense resistor a lifetime of 60000 lamp starts (with max. 7 start attempts) at maximum preheat current level of 1.4 A (RMS) is guaranteed. The number of the quality specification can be found in the “Quality Reference Handbook”. The handbook can be ordered using the code 9397 750 00192.

THERMAL CHARACTERISTICS

SYMBOL	PARAMETER	VALUE	UNIT
$R_{th\ j-a}$	thermal resistance from junction to ambient in free air	160	K/W

CHARACTERISTICS

$T_{amb} = 25\text{ °C}$; all voltages referenced to GND; see application diagrams (Figs. 7 and 8); $V_{mains} = 220\text{ V}$, 50 Hz; N is the number of ignition attempts; unless otherwise specified.

SYMBOL	PARAMETER	CONDITIONS	MIN.	TYP.	MAX.	UNIT
IC voltages						
$V_{CC(s)}$	supply voltage start level		40	44	49	V
$V_{CC(rst)}$	supply voltage reset level		–	–	9	V
V_{ign}	ignition voltage	striking switching device	67	–	97	V
Lamp voltages						
V_{lamp}	TL-lamp voltage		50	–	140	V
Supply current						
I_{CC}	supply current	$V_{CC} = 30\text{ V}$; note 1	–	32	42	μA
		after 7 th start attempt; $V_{CC} = 30\text{ V}$	–	145	–	μA
I_c	control current	note 2	–	170	–	μA

Electronic TL-lamp starter

UBA2000T

SYMBOL	PARAMETER	CONDITIONS	MIN.	TYP.	MAX.	UNIT
Output stage						
I_{source}	peak source current (pulse shape Fig.6)	$V_{out} < 2\text{ V}$; striking switching device	1.5	–	10	mA
I_{sink}	output sink current	$V_{out} = 0.8\text{ V}$	50	–	–	mA
t_W	pulse width	$V_{CC} = 30\text{ V}$	5	–	–	μs
Q_p	pulse charge	$V_{CC} = 30\text{ V}$; note 3	21	–	–	nC
V_{out}	output voltage	$I_{sink} = 0.5\text{ mA}$; driving gate device in preheat mode	–	6.8	–	V
Timing						
t_{prf}	preheat time (first)	$N = 1$; note 4	–	1.52	–	s
t_{prm}	preheat time (next)	$2 \leq N \leq 7$; note 5	–	0.64	–	s
t_{ini}	initial time		–	125	–	ms
Current protection						
$I_{prot(m)}$	current protection level (peak value)		2.2	3.4	–	A
t_d	delay time before current protection is enabled	note 6	–	70	–	ms
Sense resistor						
R_{sense}	internal sense resistor	note 7	–	26	–	$\text{m}\Omega$
Preheat current						
$I_{pr(rms)}$	preheat current (RMS value)	note 8	0.33	–	1.4	A
Switching off current						
I_{so}	preheat current level at the moment it is switched off	note 9	285	380	475	mA

Notes

- When the switching device is triggered, $I_{CC} = I_{source}$.
- This is the active current when the lamp is lit. The given value is valid for $V_{lamp} = 115\text{ V}$. The total current at V_{in} equals: $I_{in} = I_{CC} + I_c$ (leakage currents are neglected).
- $Q_p = I_{source} \times t_p$.
- Time is derived from the mains frequency; division factor equals 76.
- Time is derived from the mains frequency; division factor equals 32.
- The delay time is set by a clock signal, which is derived from the current through the sense resistor. Due to inrush transients of the preheat current, variation of t_d is possible.
- This is the resistance of the internal sense circuit (excluding the bonding wires).

- To guarantee good functioning, a crest factor of at least 1.5 is needed at low currents.
- When the holding current of TH1 is lower than I_{so} , TH1 is switched off at the holding current (in case of a trigger device).

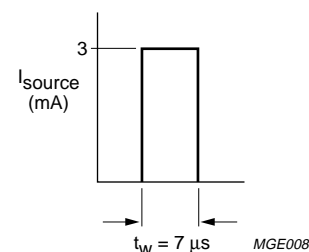

Fig.6 Pulse shape (typical value).

Electronic TL-lamp starter

UBA2000T

APPLICATION INFORMATION

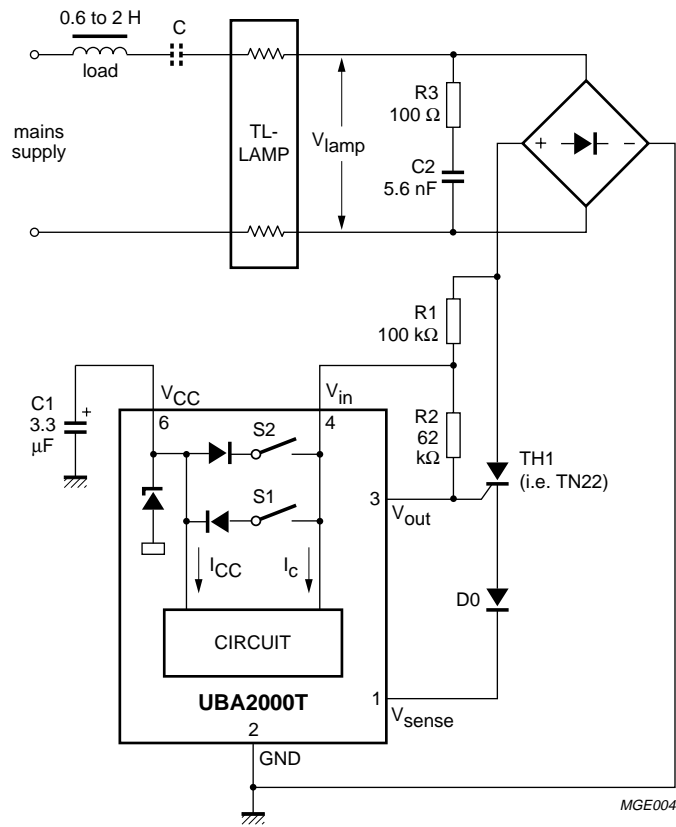

Fig.7 Application diagram (with trigger device).

Electronic TL-lamp starter

UBA2000T

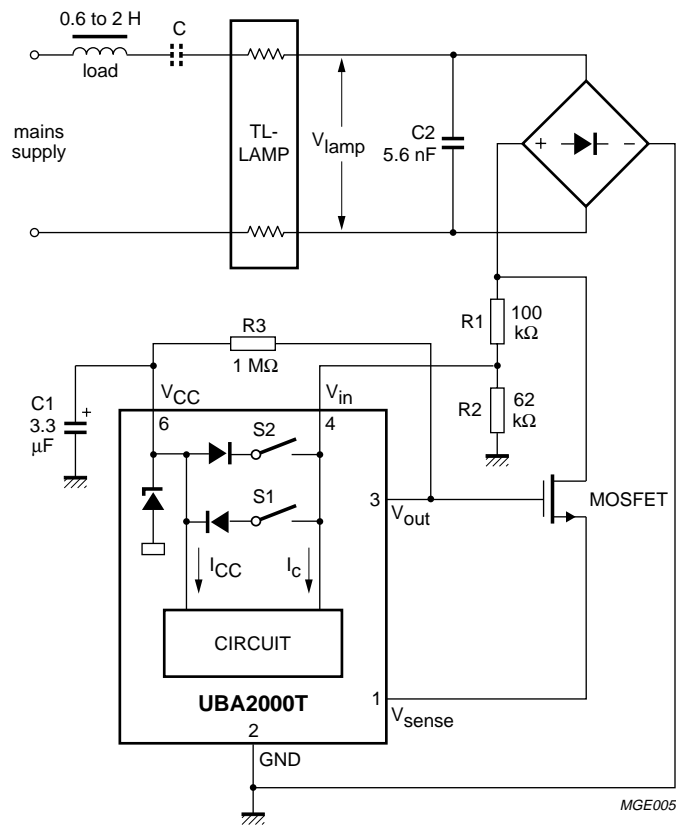

Fig.8 Application diagram (with MOSFET device).

Electronic TL-lamp starter

UBA2000T

PACKAGE OUTLINE

S08: plastic small outline package; 8 leads; body width 3.9 mm

SOT96-1

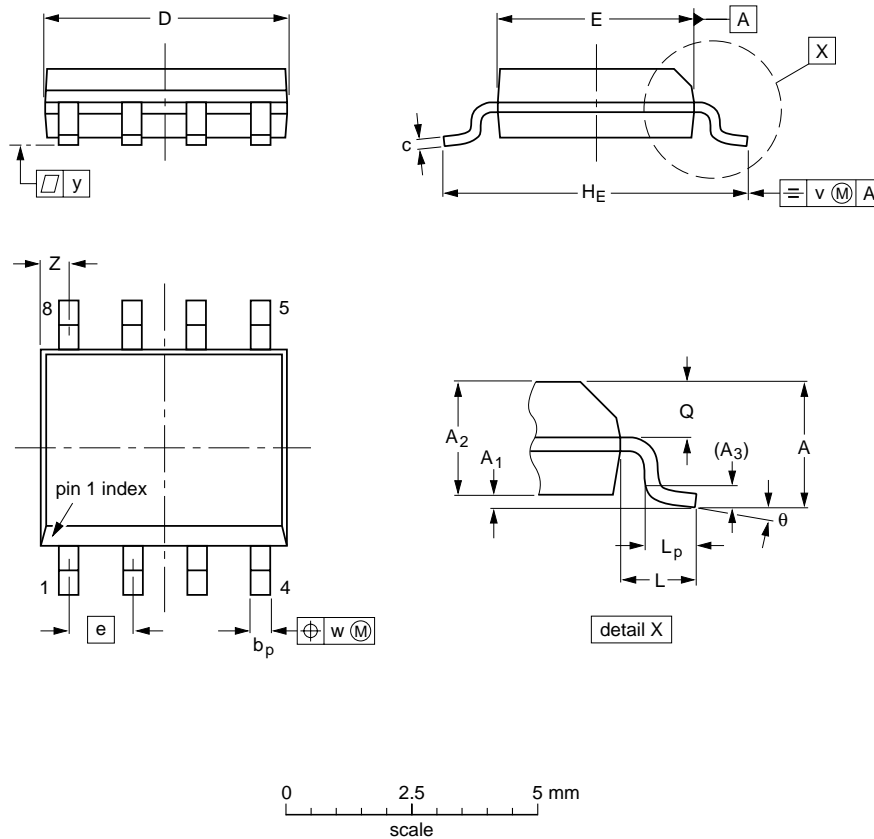

DIMENSIONS (inch dimensions are derived from the original mm dimensions)

UNIT	A max.	A ₁	A ₂	A ₃	b _p	c	D ⁽¹⁾	E ⁽²⁾	e	H _E	L	L _p	Q	v	w	y	z ⁽¹⁾	θ
mm	1.75	0.25 0.10	1.45 1.25	0.25	0.49 0.36	0.25 0.19	5.0 4.8	4.0 3.8	1.27	6.2 5.8	1.05	1.0 0.4	0.7 0.6	0.25	0.25	0.1	0.7 0.3	8° 0°
inches	0.069	0.010 0.004	0.057 0.049	0.01	0.019 0.014	0.0100 0.0075	0.20 0.19	0.16 0.15	0.050	0.244 0.228	0.041	0.039 0.016	0.028 0.024	0.01	0.01	0.004	0.028 0.012	

Notes

1. Plastic or metal protrusions of 0.15 mm maximum per side are not included.
2. Plastic or metal protrusions of 0.25 mm maximum per side are not included.

OUTLINE VERSION	REFERENCES				EUROPEAN PROJECTION	ISSUE DATE
	IEC	JEDEC	EIAJ			
SOT96-1	076E03S	MS-012AA				95-02-04 97-05-22

Electronic TL-lamp starter

UBA2000T

SOLDERING

Introduction

There is no soldering method that is ideal for all IC packages. Wave soldering is often preferred when through-hole and surface mounted components are mixed on one printed-circuit board. However, wave soldering is not always suitable for surface mounted ICs, or for printed-circuits with high population densities. In these situations reflow soldering is often used.

This text gives a very brief insight to a complex technology. A more in-depth account of soldering ICs can be found in our "*IC Package Databook*" (order code 9398 652 90011).

Reflow soldering

Reflow soldering techniques are suitable for all SO packages.

Reflow soldering requires solder paste (a suspension of fine solder particles, flux and binding agent) to be applied to the printed-circuit board by screen printing, stencilling or pressure-syringe dispensing before package placement.

Several techniques exist for reflowing; for example, thermal conduction by heated belt. Dwell times vary between 50 and 300 seconds depending on heating method. Typical reflow temperatures range from 215 to 250 °C.

Preheating is necessary to dry the paste and evaporate the binding agent. Preheating duration: 45 minutes at 45 °C.

Wave soldering

Wave soldering techniques can be used for all SO packages if the following conditions are observed:

- A double-wave (a turbulent wave with high upward pressure followed by a smooth laminar wave) soldering technique should be used.
- The longitudinal axis of the package footprint must be parallel to the solder flow.
- The package footprint must incorporate solder thieves at the downstream end.

During placement and before soldering, the package must be fixed with a droplet of adhesive. The adhesive can be applied by screen printing, pin transfer or syringe dispensing. The package can be soldered after the adhesive is cured.

Maximum permissible solder temperature is 260 °C, and maximum duration of package immersion in solder is 10 seconds, if cooled to less than 150 °C within 6 seconds. Typical dwell time is 4 seconds at 250 °C.

A mildly-activated flux will eliminate the need for removal of corrosive residues in most applications.

Repairing soldered joints

Fix the component by first soldering two diagonally-opposite end leads. Use only a low voltage soldering iron (less than 24 V) applied to the flat part of the lead. Contact time must be limited to 10 seconds at up to 300 °C. When using a dedicated tool, all other leads can be soldered in one operation within 2 to 5 seconds between 270 and 320 °C.

Electronic TL-lamp starter

UBA2000T

DEFINITIONS

Data sheet status	
Objective specification	This data sheet contains target or goal specifications for product development.
Preliminary specification	This data sheet contains preliminary data; supplementary data may be published later.
Product specification	This data sheet contains final product specifications.
Limiting values	
Limiting values given are in accordance with the Absolute Maximum Rating System (IEC 134). Stress above one or more of the limiting values may cause permanent damage to the device. These are stress ratings only and operation of the device at these or at any other conditions above those given in the Characteristics sections of the specification is not implied. Exposure to limiting values for extended periods may affect device reliability.	
Application information	
Where application information is given, it is advisory and does not form part of the specification.	

LIFE SUPPORT APPLICATIONS

These products are not designed for use in life support appliances, devices, or systems where malfunction of these products can reasonably be expected to result in personal injury. Philips customers using or selling these products for use in such applications do so at their own risk and agree to fully indemnify Philips for any damages resulting from such improper use or sale.

Electronic TL-lamp starter

UBA2000T

NOTES

Philips Semiconductors – a worldwide company

Argentina: IEROD, Av. Juramento 1992 - 14.b, (1428)
BUENOS AIRES, Tel. (541)786 7633, Fax. (541)786 9367

Australia: 34 Waterloo Road, NORTH RYDE, NSW 2113,
Tel. (02)805 4455, Fax. (02)805 4466

Austria: Triester Str. 64, A-1101 WIEN, P.O. Box 213,
Tel. (01)60 101-1236, Fax. (01)60 101-1211

Belgium: Postbus 90050, 5600 PB EINDHOVEN, The Netherlands,
Tel. (31)40-2783749, Fax. (31)40-2788399

Brazil: Rua do Rocio 220 - 5th floor, Suite 51,
CEP: 04552-903-SÃO PAULO-SP, Brazil,
P.O. Box 7383 (01064-970),
Tel. (011)821-2333, Fax. (011)829-1849

Canada: PHILIPS SEMICONDUCTORS/COMPONENTS:
Tel. (800) 234-7381, Fax. (708) 296-8556

Chile: Av. Santa Maria 0760, SANTIAGO,
Tel. (02)773 816, Fax. (02)777 6730

China/Hong Kong: 501 Hong Kong Industrial Technology Centre,
72 Tat Chee Avenue, Kowloon Tong, HONG KONG,
Tel. (852)2319 7888, Fax. (852)2319 7700

Colombia: IPRELENZO LTDA, Carrera 21 No. 56-17,
77621 BOGOTA, Tel. (571)249 7624/(571)217 4609,
Fax. (571)217 4549

Denmark: Prags Boulevard 80, PB 1919, DK-2300
COPENHAGEN S, Tel. (45)32 88 26 36, Fax. (45)31 57 19 49

Finland: Sinikalliontie 3, FIN-02630 ESPOO,
Tel. (358)0-615 800, Fax. (358)0-61580 920

France: 4 Rue du Port-aux-Vins, BP317,
92156 SURESNES Cedex,
Tel. (01)4099 6161, Fax. (01)4099 6427

Germany: P.O. Box 10 51 40, 20035 HAMBURG,
Tel. (040)23 53 60, Fax. (040)23 53 63 00

Greece: No. 15, 25th March Street, GR 17778 TAVROS,
Tel. (01)4894 339/4894 911, Fax. (01)4814 240

India: Philips INDIA Ltd, Shivsagar Estate, A Block,
Dr. Annie Besant Rd. Worli, Bombay 400 018
Tel. (022)4938 541, Fax. (022)4938 722

Indonesia: Philips House, Jalan H.R. Rasuna Said Kav. 3-4,
P.O. Box 4252, JAKARTA 12950,
Tel. (021)5201 122, Fax. (021)5205 189

Ireland: Newstead, Clonskeagh, DUBLIN 14,
Tel. (01)7640 000, Fax. (01)7640 200

Italy: PHILIPS SEMICONDUCTORS S.r.l.,
Piazza IV Novembre 3, 20124 MILANO,
Tel. (0039)2 6752 2531, Fax. (0039)2 6752 2557

Japan: Philips Bldg 13-37, Kohnan2-chome, Minato-ku, TOKYO 108,
Tel. (03)3740 5130, Fax. (03)3740 5077

Korea: Philips House, 260-199 Itaewon-dong,
Yongsan-ku, SEOUL, Tel. (02)709-1412, Fax. (02)709-1415

Malaysia: No. 76 Jalan Universiti, 46200 PETALING JAYA,
SELANGOR, Tel. (03)750 5214, Fax. (03)757 4880

Mexico: 5900 Gateway East, Suite 200, EL PASO, TX 79905,
Tel. 9-5(800)234-7381, Fax. (708)296-8556

Netherlands: Postbus 90050, 5600 PB EINDHOVEN, Bldg. VB,
Tel. (040)2783749, Fax. (040)2788399

New Zealand: 2 Wagener Place, C.P.O. Box 1041, AUCKLAND,
Tel. (09)849-4160, Fax. (09)849-7811

Norway: Box 1, Manglerud 0612, OSLO,
Tel. (022)74 8000, Fax. (022)74 8341

Pakistan: Philips Electrical Industries of Pakistan Ltd.,
Exchange Bldg. ST-2/A, Block 9, KDA Scheme 5, Clifton,
KARACHI 75600, Tel. (021)587 4641-49,
Fax. (021)577035/5874546

Philippines: PHILIPS SEMICONDUCTORS PHILIPPINES Inc.,
106 Valero St. Salcedo Village, P.O. Box 2108 MCC, MAKATI,
Metro MANILA, Tel. (63) 2 816 6380, Fax. (63) 2 817 3474

Portugal: PHILIPS PORTUGUESA, S.A.,
Rua dr. António Loureiro Borges 5, Arquiparque - Miraflores,
Apartado 300, 2795 LINDA-A-VELHA,
Tel. (01)4163160/4163333, Fax. (01)4163174/4163366

Singapore: Lorong 1, Toa Payoh, SINGAPORE 1231,
Tel. (65)350 2000, Fax. (65)251 6500

South Africa: S.A. PHILIPS Pty Ltd.,
195-215 Main Road Martindale, 2092 JOHANNESBURG,
P.O. Box 7430, Johannesburg 2000,
Tel. (011)470-5911, Fax. (011)470-5494

Spain: Balmes 22, 08007 BARCELONA,
Tel. (03)301 6312, Fax. (03)301 42 43

Sweden: Kottbygatan 7, Akalla. S-164 85 STOCKHOLM,
Tel. (0)8-632 2000, Fax. (0)8-632 2745

Switzerland: Allmendstrasse 140, CH-8027 ZÜRICH,
Tel. (01)488 2211, Fax. (01)481 77 30

Taiwan: PHILIPS TAIWAN Ltd., 23-30F, 66, Chung Hsiao West
Road, Sec. 1. Taipeh, Taiwan ROC, P.O. Box 22978,
TAIPEI 100, Tel. (886) 2 382 4443, Fax. (886) 2 382 4444

Thailand: PHILIPS ELECTRONICS (THAILAND) Ltd.,
209/2 Sanpavuth-Bangna Road Prakanong,
Bangkok 10260, THAILAND,
Tel. (66) 2 745-4090, Fax. (66) 2 398-0793

Turkey: Talatpasa Cad. No. 5, 80640 GÜLTEPE/ISTANBUL,
Tel. (0212)279 27 70, Fax. (0212)282 67 07

Ukraine: Philips UKRAINE, 2A Akademika Koroleva str., Office 165,
252148 KIEV, Tel. 380-44-4760297, Fax. 380-44-4766991

United Kingdom: Philips Semiconductors LTD.,
276 Bath Road, Hayes, MIDDLESEX UB3 5BX,
Tel. (0181)730-5000, Fax. (0181)754-8421

United States: 811 East Arques Avenue, SUNNYVALE,
CA 94088-3409, Tel. (800)234-7381, Fax. (708)296-8556

Uruguay: Coronel Mora 433, MONTEVIDEO,
Tel. (02)70-4044, Fax. (02)92 0601

Internet: <http://www.semiconductors.philips.com/ps/>

For all other countries apply to: Philips Semiconductors,
International Marketing and Sales, Building BE-p,
P.O. Box 218, 5600 MD EINDHOVEN, The Netherlands,
Telex 35000 phtcnl, Fax. +31-40-2724825

SCDS47

© Philips Electronics N.V. 1996

All rights are reserved. Reproduction in whole or in part is prohibited without the prior written consent of the copyright owner.

The information presented in this document does not form part of any quotation or contract, is believed to be accurate and reliable and may be changed without notice. No liability will be accepted by the publisher for any consequence of its use. Publication thereof does not convey nor imply any license under patent- or other industrial or intellectual property rights.

Printed in The Netherlands

297021/1100/01/pp16

Date of release: 1996 Jan 03

Document order number:

9397 750 00547