

SURFACE MOUNT GPP
TRANSIENT VOLTAGE SUPPRESSOR
400 WATT PEAK POWER 1.0 WATT STEADY STATE

FEATURES

- * Plastic package has underwriters laboratory
- * Glass passivated chip construction
- * 400 watt surge capability at 1ms
- * Excellent clamping capability
- * Low zener impedance
- * Fast response time

Ratings at 25 °C ambient temperature unless otherwise specified.

MAXIMUM RATINGS AND ELECTRICAL CHARACTERISTICS

Ratings at 25 °C ambient temperature unless otherwise specified.



DO-214AC

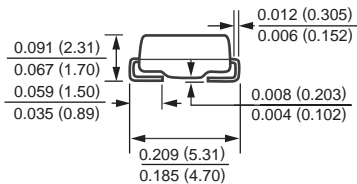
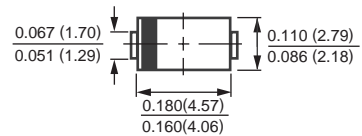

Dimensions in inches and (millimeters)

DEVICES FOR BIPOLAR APPLICATIONS

For Bidirectional use C or CA suffix for types P4FMAJ6.8 thru P4FMAJ400

Electrical characteristics apply in both direction

MAXIMUM RATINGS (At TA = 25°C unless otherwise noted)

RATINGS	SYMBOL	VALUE	UNITS
Peak Power Dissipation at TA = 25°C, TP = 1mS (Note 1)	PPPM	Minimum 400	Watts
Peak Pulse Current with a 10/1000uS waveform (Note 1, Fig.3)	IPPM	SEE TABLE 1	Amps
Steady State Power Dissipation at TL = 75°C (Note 2)	PM(AV)	1.0	Watts
Peak Forward Surge Current, 8.3mS single half sine wave-superimposed on rated load (JEDEC METHOD) (Note 3)	IFSM	40	Amps
Maximum Instantaneous Forward Voltage at 25A for unidirectional only (Note 4)	VF	3.5/6.5	Volts
Operating and Storage Temperature Range	TJ, TstG	-55 to + 150	°C

NOTES : 1. Non-repetitive current pulse, per Fig.3 and derated above TA = 25°C per Fig.2.

2. Mounted on 0.2 X 0.2" (5.0 X 5.0mm) copper pad to each terminal.

3. Measured on 8.3mS single half Sine-Wave or equivalent wave, duty cycle = 4 pulses per minute maximum.

4. VF = 3.0V max. for devices of V(BR) ≤ 200V and VF = 5.0V max. for devices of V(BR) ≥ 200V.

RATING AND CHARACTERISTIC CURVES (P4FMAJ6.8 THRU P4FMAJ400CA)

FIG. 1 - PEAK PULSE POWER RATING CURVE

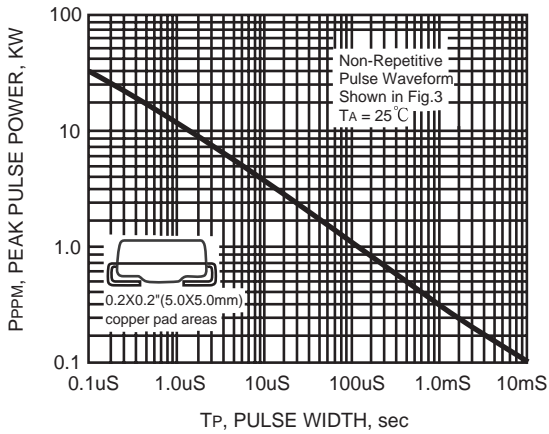

FIG. 2 - PULSE DERATING CURVE

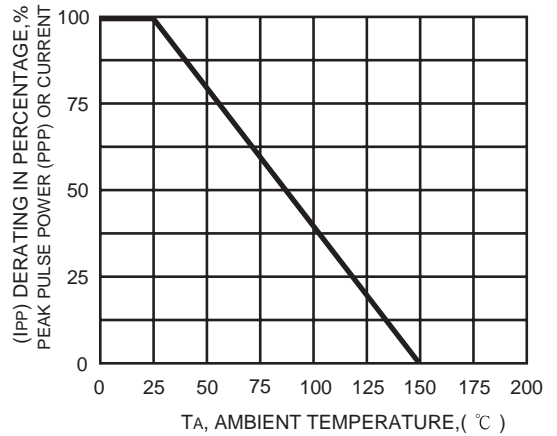

FIG. 3 - PULSE WAVEFORM

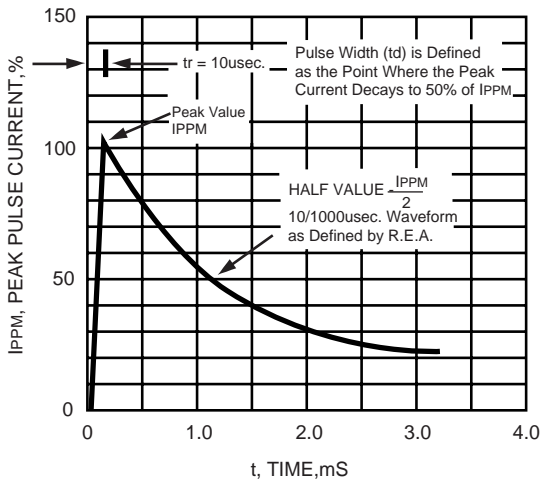
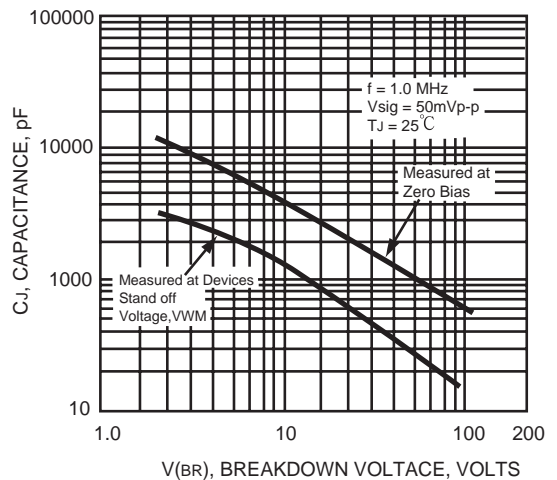

FIG. 4 - TYPICAL JUNCTION CAPACITANCE



RATING AND CHARACTERISTIC CURVES (P4FMAJ6.8 THRU P4FMAJ400CA)

FIG. 5 - STEADY STATE POWER DERATING CURVE

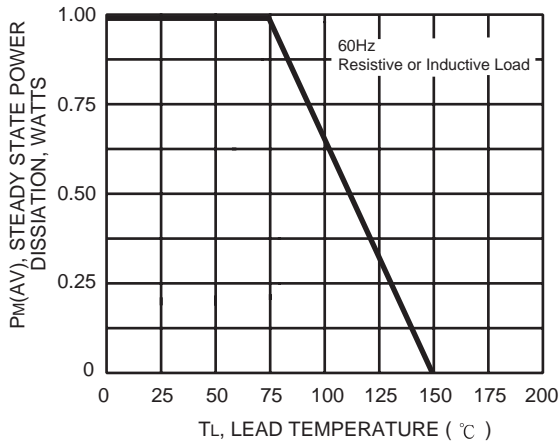

FIG. 6 - MAXIMUM NON-REPETITIVE FORWARD SURGE CURRENT UNIDIRECTIONAL

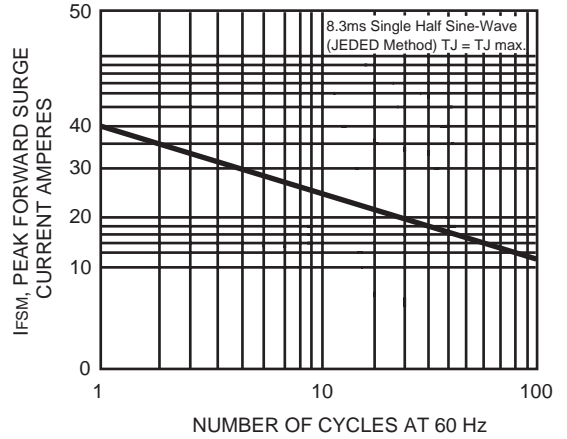
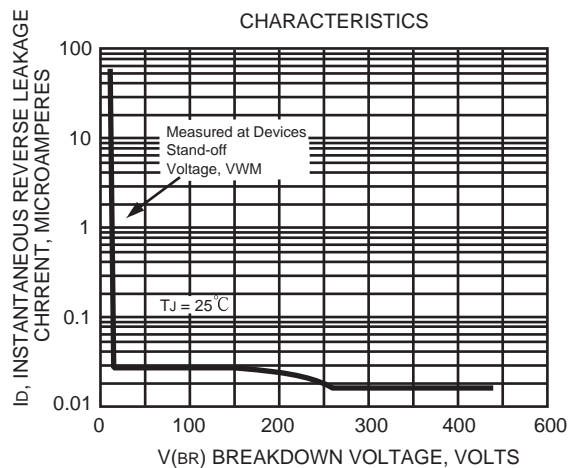

FIG. 7 - TYPICAL REVERSE LEAKAGE CHARACTERISTICS



TRANSIENT VOLTAGE SUPPRESSORS

400W SERIES TVS DIODES / DO-214AC (CASE 2) 400W

TYPE	Breakdown Voltage		@I _T (mA)	Reverse Stand off Voltage V _{WM} (Volts)	Maximum Reverse Leakage at V _{WM} I _D (uA)	Maximum Peak Pulse Current I _{PPM} (Amps)	Maximum Clamping Voltage at I _{PPM} V _C (Volts)
	V _{BR} (Volts)						
	MIN.	MAX.					
P4FMAJ6.8	6.12	7.48	10	5.50	1000	37	10.8
P4FMAJ6.8A	6.45	7.14	10	5.80	1000	38.1	10.5
P4FMAJ7.5	6.75	8.25	10	6.05	500	34.2	11.7
P4FMAJ7.5A	7.13	7.88	10	6.40	500	35.4	11.3
P4FMAJ8.2	7.38	9.02	10	6.63	200	32	12.5
P4FMAJ8.2A	7.79	8.61	10	7.02	200	33.1	12.1
P4FMAJ9.1	8.19	10.0	1.0	7.37	50	29	13.8
P4FMAJ9.1A	8.65	9.55	1.0	7.78	50	29.9	13.4
P4FMAJ10	9.00	11.0	1.0	8.10	10	26.7	15.0
P4FMAJ10A	9.50	10.5	1.0	8.55	10	27.6	14.5
P4FMAJ11	9.90	12.1	1.0	8.92	5.0	24.7	16.2
P4FMAJ11A	10.5	11.6	1.0	9.40	5.0	25.6	15.6
P4FMAJ12	10.8	13.2	1.0	9.72	5.0	23.1	17.3
P4FMAJ12A	11.4	12.6	1.0	10.2	5.0	24	16.7
P4FMAJ13	11.7	14.3	1.0	10.5	5.0	21.1	19.0
P4FMAJ13A	12.4	13.7	1.0	11.1	5.0	22	18.2
P4FMAJ15	13.5	16.3	1.0	12.1	5.0	18.2	22.0
P4FMAJ15A	14.3	15.8	1.0	12.8	5.0	18.9	21.2
P4FMAJ16	14.4	17.6	1.0	12.9	5.0	17	23.5
P4FMAJ16A	15.2	16.8	1.0	13.6	5.0	17.8	22.5
P4FMAJ18	16.2	19.8	1.0	14.5	5.0	15.1	26.5
P4FMAJ18A	17.1	18.9	1.0	15.3	5.0	15.9	25.2
P4FMAJ20	18.0	22.0	1.0	16.2	5.0	13.7	29.1
P4FMAJ20A	19.0	21.0	1.0	17.1	5.0	14.4	27.7
P4FMAJ22	19.8	24.2	1.0	17.8	5.0	12.5	31.9
P4FMAJ22A	20.9	23.1	1.0	18.8	5.0	13.1	30.6
P4FMAJ24	21.6	26.4	1.0	19.4	5.0	11.5	34.7
P4FMAJ24A	22.8	25.2	1.0	20.5	5.0	12	33.2
P4FMAJ27	24.3	29.7	1.0	21.8	5.0	10.2	39.1
P4FMAJ27A	25.7	28.4	1.0	23.1	5.0	10.7	37.5
P4FMAJ30	27.0	33.0	1.0	24.3	5.0	9.2	43.5
P4FMAJ30A	28.5	31.5	1.0	25.6	5.0	9.7	41.4
P4FMAJ33	29.7	36.3	1.0	26.8	5.0	8.4	47.7
P4FMAJ33A	31.4	34.7	1.0	28.2	5.0	8.8	45.7
P4FMAJ36	32.4	39.6	1.0	29.1	5.0	7.7	52.0
P4FMAJ36A	34.2	37.8	1.0	30.8	5.0	8	49.9
P4FMAJ39	35.1	42.9	1.0	31.6	5.0	7.1	56.4
P4FMAJ39A	37.1	41.0	1.0	33.3	5.0	7.4	53.9
P4FMAJ43	38.7	47.3	1.0	34.8	5.0	6.5	61.9
P4FMAJ43A	40.9	45.2	1.0	36.8	5.0	6.7	59.3
P4FMAJ47	42.3	51.7	1.0	38.1	5.0	5.9	67.8
P4FMAJ47A	44.7	49.4	1.0	40.2	5.0	6.2	64.8
P4FMAJ51	45.9	56.1	1.0	41.3	5.0	5.4	73.5
P4FMAJ51A	48.5	53.6	1.0	43.6	5.0	5.7	70.1
P4FMAJ56	50.4	61.6	1.0	45.4	5.0	5.0	80.5
P4FMAJ56A	53.2	58.8	1.0	47.8	5.0	5.2	77.0

TRANSIENT VOLTAGE SUPPRESSORS

400W SERIES TVS DIODES / DO-214AC (CASE 2) 400W

TYPE	Breakdown Voltage		@I _T (mA)	Reverse Stand off Voltage V _{WM} (Volts)	Maximum Reverse Leakage at V _{WM} I _D (uA)	Maximum Peak Pulse Current I _{PPM} (Amps)	Maximum Clamping Voltage at I _{PPM} V _C (Volts)
	V _{BR} (Volts)						
	MIN.	MAX.					
P4FMAJ62	55.8	68.2	1.0	50.2	5.0	4.7	89.0
P4FMAJ62A	58.9	65.1	1.0	53.0	5.0	5.0	85.0
P4FMAJ68	61.2	74.8	1.0	55.1	5.0	4.2	98.0
P4FMAJ68A	64.6	71.4	1.0	58.1	5.0	4.5	92.0
P4FMAJ75	67.5	82.5	1.0	60.7	5.0	3.8	108
P4FMAJ75A	71.3	78.8	1.0	64.1	5.0	4.0	103
P4FMAJ82	73.8	90.2	1.0	66.4	5.0	3.5	118
P4FMAJ82A	77.9	86.1	1.0	70.1	5.0	3.7	113
P4FMAJ91	81.9	100	1.0	73.7	5.0	3.2	131
P4FMAJ91A	86.5	95.5	1.0	77.8	5.0	3.3	125
P4FMAJ100	90.0	110	1.0	81.0	5.0	2.9	144
P4FMAJ100A	95.0	105	1.0	85.5	5.0	3.0	137
P4FMAJ110	99.0	121	1.0	89.2	5.0	2.6	158
P4FMAJ110A	105	116	1.0	94.0	5.0	2.7	152
P4FMAJ120	108	132	1.0	97.2	5.0	2.4	173
P4FMAJ120A	114	126	1.0	102	5.0	2.5	165
P4FMAJ130	117	143	1.0	105	5.0	2.2	187
P4FMAJ130A	124	137	1.0	111	5.0	2.3	179
P4FMAJ150	135	165	1.0	121	5.0	1.9	215
P4FMAJ150A	143	158	1.0	128	5.0	2.0	207
P4FMAJ160	144	176	1.0	130	5.0	1.8	230
P4FMAJ160A	152	168	1.0	136	5.0	1.9	219
P4FMAJ170	153	187	1.0	138	5.0	1.7	244
P4FMAJ170A	162	179	1.0	145	5.0	1.8	234
P4FMAJ180	162	198	1.0	146	5.0	1.6	258
P4FMAJ180A	171	189	1.0	154	5.0	1.7	246
P4FMAJ200	180	220	1.0	162	5.0	1.4	287
P4FMAJ200A	190	210	1.0	171	5.0	1.5	274
P4FMAJ220	198	242	1.0	175	5.0	1.2	344
P4FMAJ220A	209	231	1.0	185	5.0	1.3	328
P4FMAJ250	225	275	1.0	202	5.0	1.1	360
P4FMAJ250A	237	263	1.0	214	5.0	1.2	344
P4FMAJ300	270	330	1.0	243	5.0	0.97	430
P4FMAJ300A	285	315	1.0	256	5.0	1.00	414
P4FMAJ350	315	385	1.0	284	5.0	0.83	504
P4FMAJ350A	332	368	1.0	300	5.0	0.87	482
P4FMAJ400	360	440	1.0	324	5.0	0.73	574
P4FMAJ400A	380	420	1.0	342	5.0	0.76	548

- Notes :
1. V_{BR} measured after I_T applied for 300ms. I_T = square pulse or equivalent.
 2. For bidirectional use C or CA suffixs for all types (ex. P4FMAJ6.8C,P4FMAJ400CA) electrical characteristics apply in both directions.
 3. For bidirectional types having V_{WM} of 10 volts and less, the I_D limit is doubled.

Mounting Pad Layout

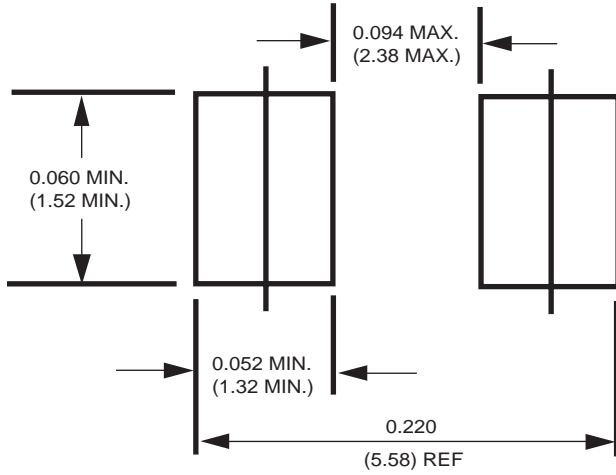

Dimensions in inches and (millimeters)