

## OUTLINE

The Rx5RL Series are CMOS-based voltage regulator ICs with high accuracy output voltage and ultra-low quiescent current. Each of these ICs consists of a voltage reference unit, an error amplifier, a driver transistor, and resistors for setting output voltage. The output voltage is fixed with high accuracy.

Three types of packages, TO-92, SOT-89 (Mini-power Mold), SOT-23-5 (Mini-mold), are available.

## FEATURES

- Ultra-low Quiescent Current .....Typ. 1.1 $\mu$ A (Rx5RL30A,  $V_{IN}$ =5.0V)
- Small Dropout Voltage .....Typ. 30mV (Rx5RL50A,  $I_{OUT}$ =1mA)
- Low Temperature-Drift Coefficient of Output Voltage .....Typ.  $\pm$ 100 ppm/ $^{\circ}$ C
- Excellent Line Regulation .....Typ. 0.1%/V
- Output Voltage .....Stepwise setting with a step of 0.1V in the range of 2.0V to 6.0V is possible (refer to Selection Guide).
- High Accuracy Output Voltage ..... $\pm$ 2.5%
- Three Types of Packages .....TO-92, SOT-89 (Mini-power Mold), SOT-23-5 (Mini-mold)

## APPLICATIONS

- Power source for battery-powered equipment.
- Power source for cameras, video instruments such as camcorders, VCRs, and hand-held communication equipment.
- Precision voltage references.

## BLOCK DIAGRAM

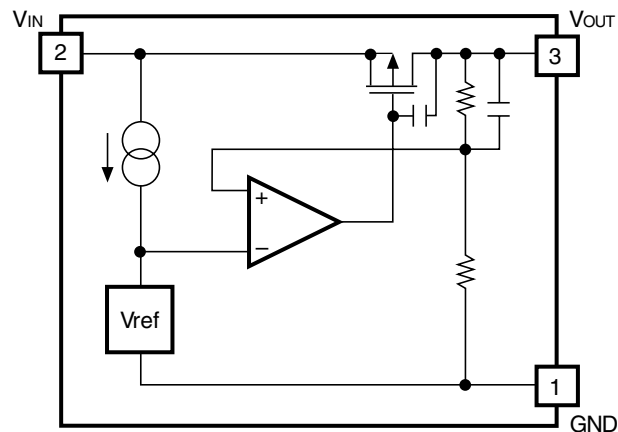

## SELECTION GUIDE

The package type, the output voltage, the packing type, and the taping type of Rx5RL Series can be designated at the user's request by specifying the part number as follows:

Rx5RLx x x x - x x ← Part Number  
 ↑     ↑ ↑     ↑  
 a     b c d   e

Code	Contents
a	Designation of Package Type: E: TO-92 H: SOT-89 (Mini-power Mold) N: SOT-23-5 (Mini-mold)
b	Setting Output Voltage (V <sub>OUT</sub> ): Stepwise setting with a step of 0.1V in the range of 2.0V to 6.0V is possible.
c	A
d	Designation of Packing Type: A: Taping C: Antistatic bag for TO-92 and samples
e	Designation of Taping Type: Ex. TO-92 : RF, RR, TZ SOT-89 : T1, T2 SOT-23-5 : TR, TL (Refer to Taping Specifications) "TZ", "T1", and "TR" are prescribed as standard directions.

For example, the product with package type SOT-89, output voltage 5.0V, version A, and taping type T1 is designated as the part number "RH5RL50AA-T1".

## PIN CONFIGURATION

### • TO-92

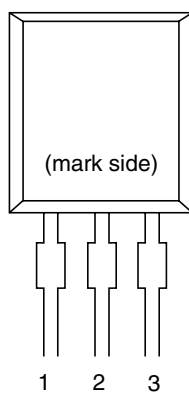

### • SOT-89

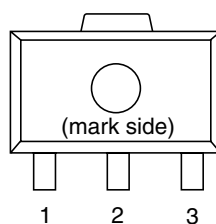

### • SOT-23-5

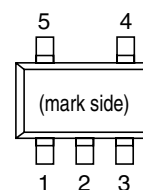

## PIN DESCRIPTION

### • TO-92

Pin No.	Symbol
1	GND
2	V <sub>IN</sub>
3	V <sub>OUT</sub>

### • SOT-89

Pin No.	Symbol
1	GND
2	V <sub>IN</sub>
3	V <sub>OUT</sub>

### • SOT-23-5

Pin No.	Symbol
1	GND
2	V <sub>IN</sub>
3	V <sub>OUT</sub>
4	NC
5	NC

**ABSOLUTE MAXIMUM RATINGS**T<sub>opt</sub>=25°C

Symbol	Item	Rating	Unit
V <sub>IN</sub>	Input Voltage	+12	V
V <sub>OUT</sub>	Output Voltage	-0.3 to V <sub>IN</sub> +0.3	V
I <sub>OUT</sub>	Output Current	150	mA
PD1	Power Dissipation 1 (NOTE1)	300	mW
PD2	Power Dissipation 2 (NOTE2)	150	mW
T <sub>opt</sub>	Operating Temperature	- 40 to +85	°C
T <sub>stg</sub>	Storage Temperature	- 55 to +125	°C
T <sub>solder</sub>	Lead Temperature (Soldering)	260°C,10s	

(NOTE 1) applied to SOT-89 and TO-92

(NOTE 2) applied to SOT-23-5

**ABSOLUTE MAXIMUM RATINGS**

Absolute Maximum ratings are threshold limit values that must not be exceeded even for an instant under any conditions. Moreover, such values for any two items must not be reached simultaneously. Operation above these absolute maximum ratings may cause degradation or permanent damage to the device. These are stress ratings only and do not necessarily imply functional operation below these limits.

## ELECTRICAL CHARACTERISTICS

### • Rx5RL20A

T<sub>opt</sub>=25°C

Symbol	Item	Conditions	Min.	Typ.	Max.	Unit
V <sub>OUT</sub>	Output Voltage	V <sub>IN</sub> =4.0V 10μA≤I <sub>OUT</sub> ≤10mA	1.950	2.000	2.050	V
I <sub>OUT</sub>	Output Current	V <sub>IN</sub> =4.0V	25	35		mA
$\frac{\Delta V_{OUT}}{\Delta I_{OUT}}$	Load Regulation	V <sub>IN</sub> =4.0V 1mA≤I <sub>OUT</sub> ≤35mA		30	45	mV
V <sub>DIF</sub>	Dropout Voltage	I <sub>OUT</sub> =1mA		60	90	mV
I <sub>SS</sub>	Quiescent Current	V <sub>IN</sub> =4.0V		1.0	3.0	μA
$\frac{\Delta V_{OUT}}{\Delta V_{IN}}$	Line Regulation	I <sub>OUT</sub> =1mA V <sub>OUT</sub> +0.5V≤V <sub>IN</sub> ≤10V		0.05	0.20	%/V
V <sub>IN</sub>	Input Voltage				10	V
$\frac{\Delta V_{OUT}}{\Delta T_{opt}}$	Output Voltage Temperature Coefficient	I <sub>OUT</sub> =10mA -40°C≤T <sub>opt</sub> ≤85°C		±100		ppm/°C

### • Rx5RL30A

T<sub>opt</sub>=25°C

Symbol	Item	Conditions	Min.	Typ.	Max.	Unit
V <sub>OUT</sub>	Output Voltage	V <sub>IN</sub> =5.0V 10μA≤I <sub>OUT</sub> ≤10mA	2.925	3.000	3.075	V
I <sub>OUT</sub>	Output Current	V <sub>IN</sub> =5.0V	35	50		mA
$\frac{\Delta V_{OUT}}{\Delta I_{OUT}}$	Load Regulation	V <sub>IN</sub> =5.0V 1mA≤I <sub>OUT</sub> ≤50mA		40	60	mV
V <sub>DIF</sub>	Dropout Voltage	I <sub>OUT</sub> =1mA		40	60	mV
I <sub>SS</sub>	Quiescent Current	V <sub>IN</sub> =5.0V		1.1	3.3	μA
$\frac{\Delta V_{OUT}}{\Delta V_{IN}}$	Line Regulation	I <sub>OUT</sub> =1mA V <sub>OUT</sub> +0.5V≤V <sub>IN</sub> ≤10V		0.05	0.20	%/V
V <sub>IN</sub>	Input Voltage				10	V
$\frac{\Delta V_{OUT}}{\Delta T_{opt}}$	Output Voltage Temperature Coefficient	I <sub>OUT</sub> =10mA -40°C≤T <sub>opt</sub> ≤85°C		±100		ppm/°C

**Rx5RL****• Rx5RL40A**T<sub>opt</sub>=25°C

Symbol	Item	Conditions	Min.	Typ.	Max.	Unit
V <sub>OUT</sub>	Output Voltage	V <sub>IN</sub> =6.0V 10μA≤I <sub>OUT</sub> ≤10mA	3.900	4.000	4.100	V
I <sub>OUT</sub>	Output Current	V <sub>IN</sub> =6.0V	45	65		mA
$\frac{\Delta V_{OUT}}{\Delta I_{OUT}}$	Load Regulation	V <sub>IN</sub> =6.0V 1mA≤I <sub>OUT</sub> ≤65mA		50	75	mV
V <sub>DIF</sub>	Dropout Voltage	I <sub>OUT</sub> =1mA		25	38	mV
I <sub>SS</sub>	Quiescent Current	V <sub>IN</sub> =6.0V		1.2	3.6	μA
$\frac{\Delta V_{OUT}}{\Delta V_{IN}}$	Line Regulation	I <sub>OUT</sub> =1mA V <sub>OUT</sub> +0.5V≤V <sub>IN</sub> ≤10V		0.05	0.20	%/V
V <sub>IN</sub>	Input Voltage				10	V
$\frac{\Delta V_{OUT}}{\Delta T_{opt}}$	Output Voltage Temperature Coefficient	I <sub>OUT</sub> =10mA -40°C≤T <sub>opt</sub> ≤85°C		±100		ppm/°C

**• Rx5RL50A**T<sub>opt</sub>=25°C

Symbol	Item	Conditions	Min.	Typ.	Max.	Unit
V <sub>OUT</sub>	Output Voltage	V <sub>IN</sub> =7.0V 10μA≤I <sub>OUT</sub> ≤10mA	4.875	5.000	5.125	V
I <sub>OUT</sub>	Output Current	V <sub>IN</sub> =7.0V	55	80		mA
$\frac{\Delta V_{OUT}}{\Delta I_{OUT}}$	Load Regulation	V <sub>IN</sub> =7.0V 1mA≤I <sub>OUT</sub> ≤80mA		60	90	mV
V <sub>DIF</sub>	Dropout Voltage	I <sub>OUT</sub> =1mA		25	38	mV
I <sub>SS</sub>	Quiescent Current	V <sub>IN</sub> =7.0V		1.3	3.9	μA
$\frac{\Delta V_{OUT}}{\Delta V_{IN}}$	Line Regulation	I <sub>OUT</sub> =1mA V <sub>OUT</sub> +0.5V≤V <sub>IN</sub> ≤10V		0.05	0.20	%/V
V <sub>IN</sub>	Input Voltage				10	V
$\frac{\Delta V_{OUT}}{\Delta T_{opt}}$	Output Voltage Temperature Coefficient	I <sub>OUT</sub> =10mA -40°C≤T <sub>opt</sub> ≤85°C		±100		ppm/°C

## • Rx5RL60A

T<sub>opt</sub>=25°C

Symbol	Item	Conditions	Min.	Typ.	Max.	Unit
V <sub>OUT</sub>	Output Voltage	V <sub>IN</sub> =8.0V 10μA≤I <sub>OUT</sub> ≤10mA	5.850	6.000	6.150	V
I <sub>OUT</sub>	Output Current	V <sub>IN</sub> =8.0V	55	80		mA
$\frac{\Delta V_{OUT}}{\Delta I_{OUT}}$	Load Regulation	V <sub>IN</sub> =8.0V 1mA≤I <sub>OUT</sub> ≤80mA		60	90	mV
V <sub>DIF</sub>	Dropout Voltage	I <sub>OUT</sub> =1mA		25	38	mV
I <sub>SS</sub>	Quiescent Current	V <sub>IN</sub> =8.0V		1.3	3.9	μA
$\frac{\Delta V_{OUT}}{\Delta V_{IN}}$	Line Regulation	I <sub>OUT</sub> =1mA V <sub>OUT</sub> +0.5V≤V <sub>IN</sub> ≤10V		0.05	0.20	%/V
V <sub>IN</sub>	Input Voltage				10	V
$\frac{\Delta V_{OUT}}{\Delta T_{opt}}$	Output Voltage Temperature Coefficient	I <sub>OUT</sub> =10mA -40°C≤T <sub>opt</sub> ≤85°C		±100		ppm/°C

## ELECTRICAL CHARACTERISTICS BY OUTPUT VOLTAGE

Part Number	Output Voltage				Output Current			Load Regulation			Dropout Voltage		
	V <sub>OUT</sub> (V)				I <sub>OUT</sub> (mA)			ΔV <sub>OUT</sub> (mV)			V <sub>DIF</sub> (mV)		
	Conditions	Min.	Typ.	Max.	Conditions	Min.	Typ.	Conditions	Typ.	Max.	Conditions	Typ.	Max.
Rx5RL20A	V <sub>IN</sub> - V <sub>OUT</sub> =2.0V  10μA≤ I <sub>OUT</sub> ≤10mA	1.950	2.000	2.050	V <sub>IN</sub> - V <sub>OUT</sub> =2.0V	25	35	V <sub>IN</sub> - V <sub>OUT</sub> =2.0V  1mA≤ I <sub>OUT</sub> ≤35mA	30	45	I <sub>OUT</sub> =1mA	60	90
Rx5RL21A		2.048	2.100	2.152									
Rx5RL22A		2.145	2.200	2.255									
Rx5RL23A		2.243	2.300	2.357									
Rx5RL24A		2.340	2.400	2.460									
Rx5RL25A		2.438	2.500	2.562									
Rx5RL26A		2.535	2.600	2.665									
Rx5RL27A		2.633	2.700	2.767									
Rx5RL28A		2.730	2.800	2.870									
Rx5RL29A		2.828	2.900	2.972									
Rx5RL30A		2.925	3.000	3.075									
Rx5RL31A		3.023	3.100	3.177									
Rx5RL32A		3.120	3.200	3.280									
Rx5RL33A		3.218	3.300	3.382									
Rx5RL34A		3.315	3.400	3.485									
Rx5RL35A		3.413	3.500	3.587									
Rx5RL36A		3.510	3.600	3.690									
Rx5RL37A		3.608	3.700	3.792									
Rx5RL38A		3.705	3.800	3.895									
Rx5RL39A		3.803	3.900	3.997									
Rx5RL40A		3.900	4.000	4.100									
Rx5RL41A		3.998	4.100	4.202									
Rx5RL42A		4.095	4.200	4.305									
Rx5RL43A		4.193	4.300	4.407									
Rx5RL44A		4.290	4.400	4.510									
Rx5RL45A		4.388	4.500	4.612									
Rx5RL46A		4.485	4.600	4.715									
Rx5RL47A		4.583	4.700	4.817									
Rx5RL48A		4.680	4.800	4.920									
Rx5RL49A		4.778	4.900	5.022									
Rx5RL50A	4.875	5.000	5.125										
Rx5RL51A	4.973	5.100	5.227										
Rx5RL52A	5.070	5.200	5.330										
Rx5RL53A	5.168	5.300	5.432										
Rx5RL54A	5.265	5.400	5.535										
Rx5RL55A	5.363	5.500	5.637										
Rx5RL56A	5.460	5.600	5.740										
Rx5RL57A	5.558	5.700	5.842										
Rx5RL58A	5.655	5.800	5.945										
Rx5RL59A	5.753	5.900	6.047										
Rx5RL60A	5.850	6.000	6.150										
												25	38
						35	50	V <sub>IN</sub> - V <sub>OUT</sub> =2.0V  1mA≤ I <sub>OUT</sub> ≤50mA	40	60		35	53
						45	65	V <sub>IN</sub> - V <sub>OUT</sub> =2.0V  1mA≤ I <sub>OUT</sub> ≤65mA	50	70			
						55	80	V <sub>IN</sub> - V <sub>OUT</sub> =2.0V  1mA≤ I <sub>OUT</sub> ≤80mA	60	90			



T<sub>opt</sub>=25°C

Quiescent Current			Line Regulation			Input Voltage	Output Voltage Tempco.	
I <sub>SS</sub> (μA)			ΔV <sub>OUT</sub> /ΔV <sub>IN</sub> (%/V)			V <sub>IN</sub> (V)	ΔV <sub>OUT</sub> /ΔT(ppm/°C)	
Conditions	Typ.	Max.	Conditions	Typ.	Max.	Max.	Conditions	Typ.
V <sub>IN</sub> V <sub>OUT</sub> =2.0V	1.0	3.0	I <sub>OUT</sub> =1mA  V <sub>OUT</sub> + 0.5V≤ V <sub>IN</sub> ≤ ≤10V	0.05	0.2	10	I <sub>OUT</sub> =10mA  -40°C≤ T <sub>opt</sub> 85°C	±100
	1.1	3.3						
	1.2	3.6						
	1.3	3.9						

## OPERATION

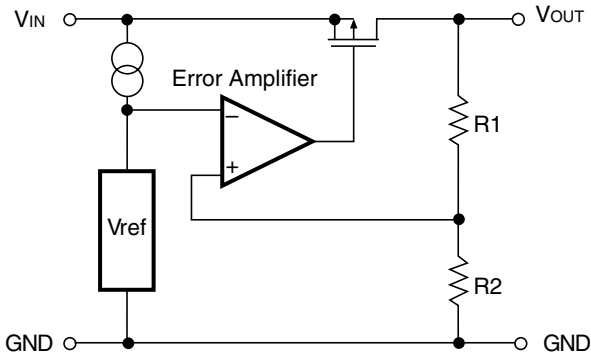

FIG. 1 Block Diagram

Output voltage,  $V_{OUT}$  divided at the node between Registers R1 and R2 is compared with the reference voltage by the error amplifier, so that a constant voltage is output.

## TEST CIRCUITS

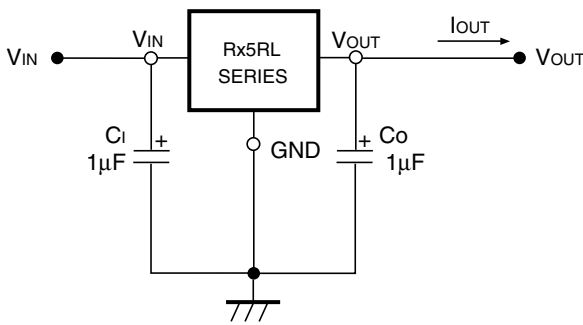

FIG. 2 Test Circuit

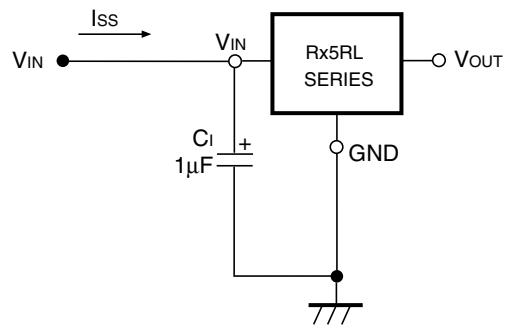

FIG. 3 Quiescent Current Test Circuit

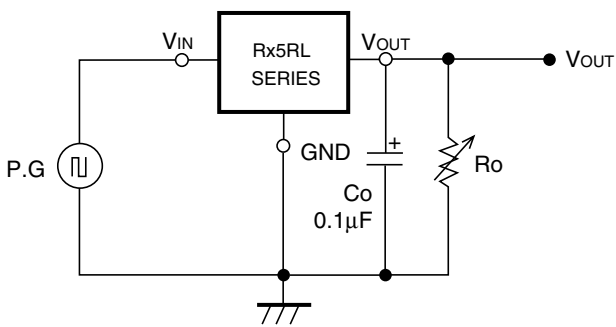
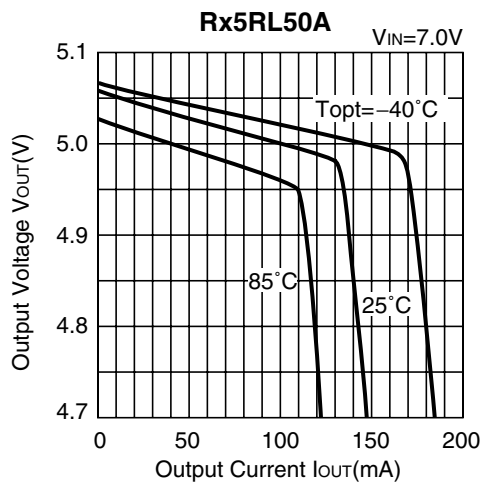
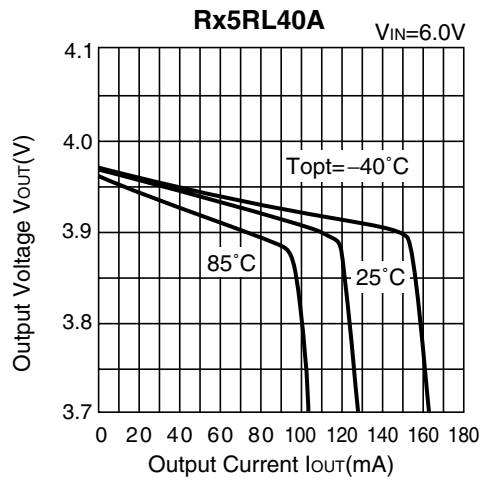
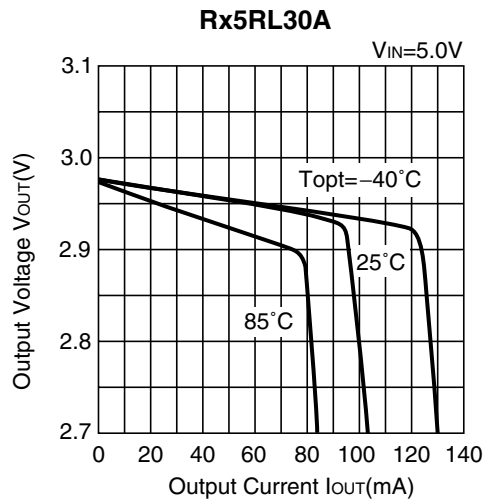

FIG. 4 Line Transient Response Test Circuit

# TYPICAL CHARACTERISTICS

## 1) Output Voltage vs. Output Current



## 2) Output Voltage vs. Input Voltage

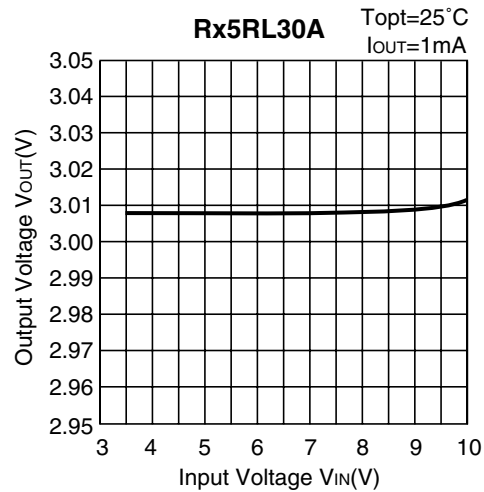
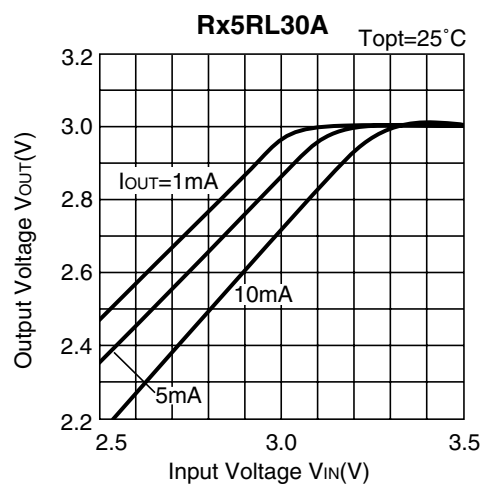

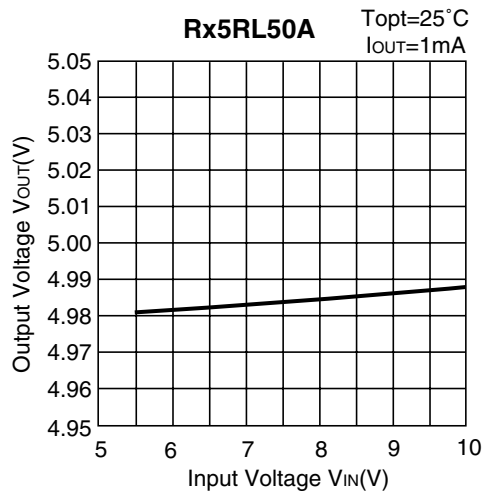
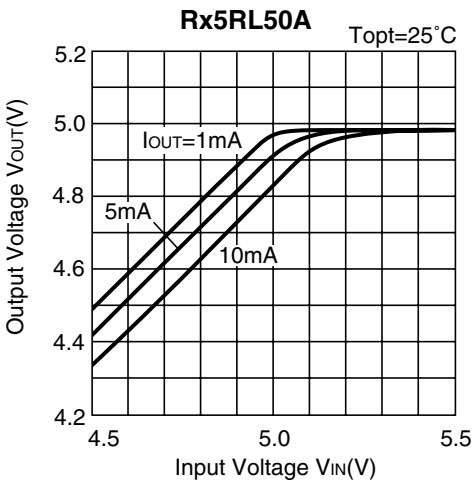
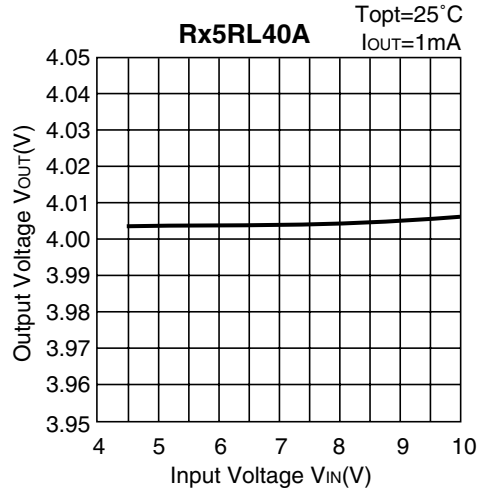
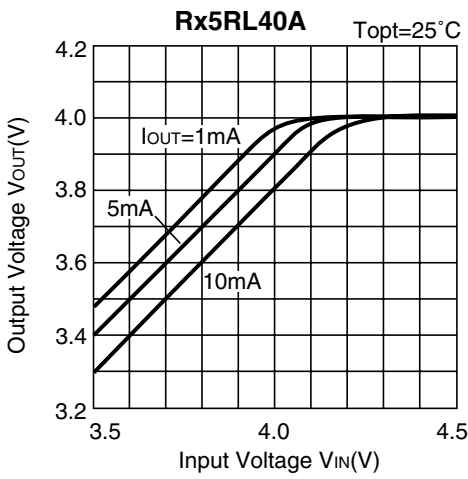

### 3) Dropout Voltage vs. Output Current

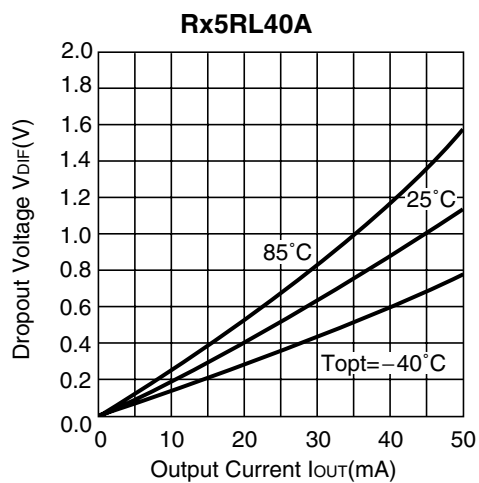
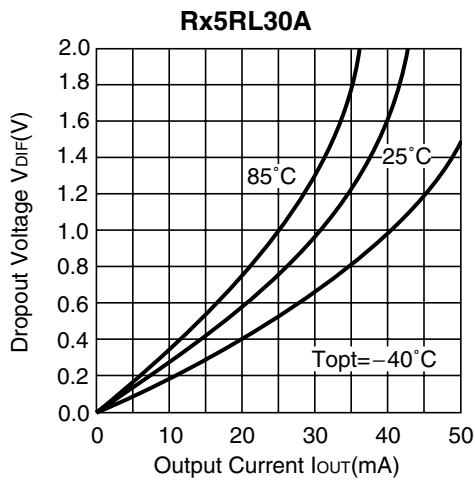

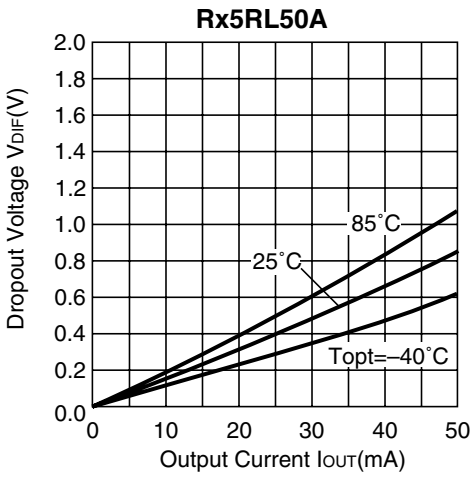

4) Output Voltage vs. Temperature

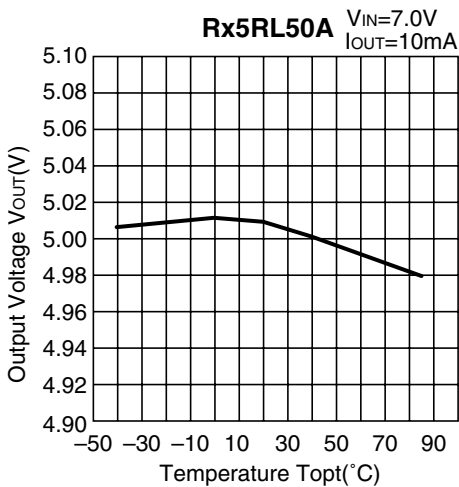
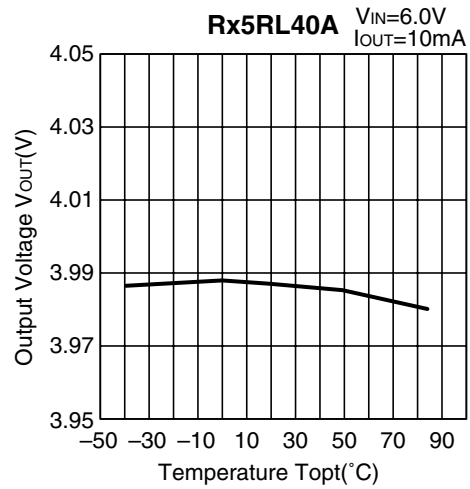
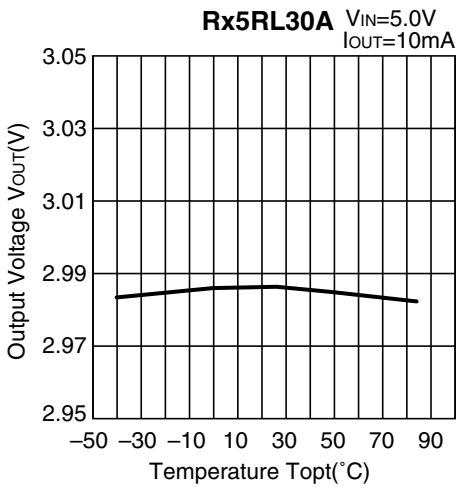

5) Quiescent Current vs. Input Voltage

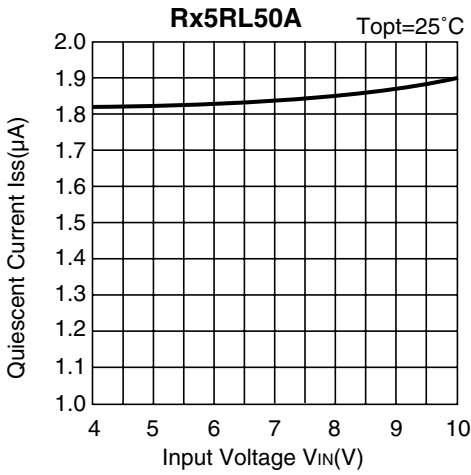
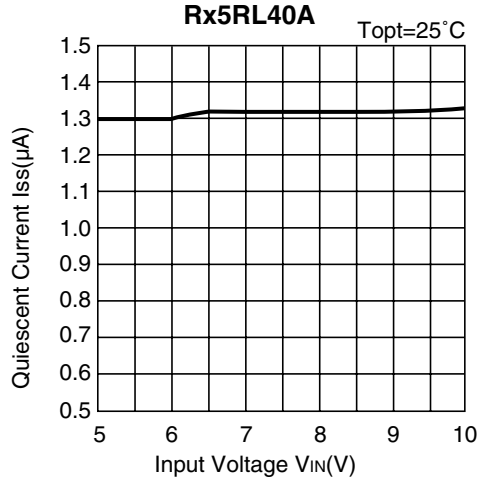
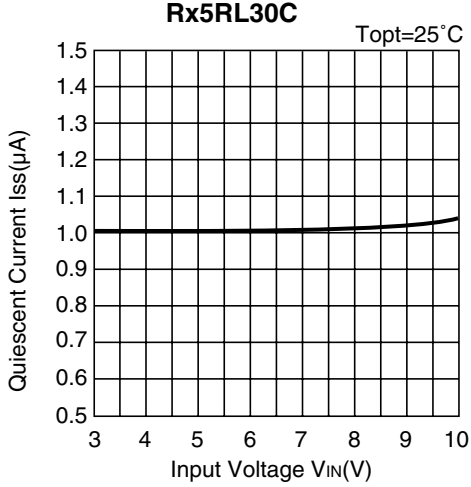

6) Quiescent Current vs. Temperature

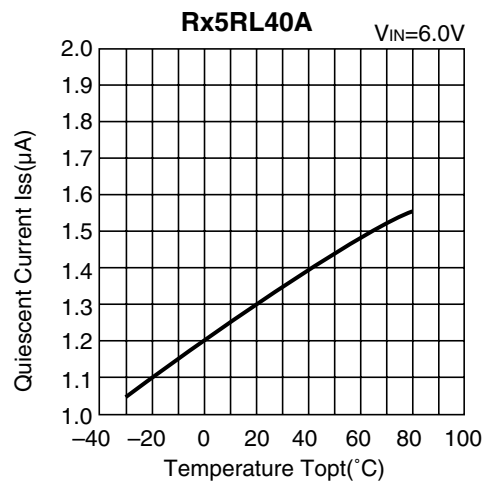
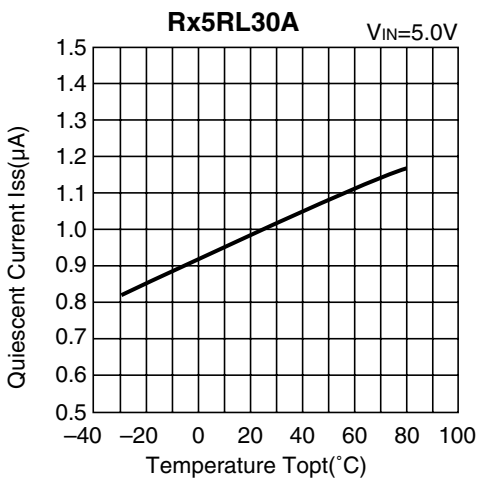

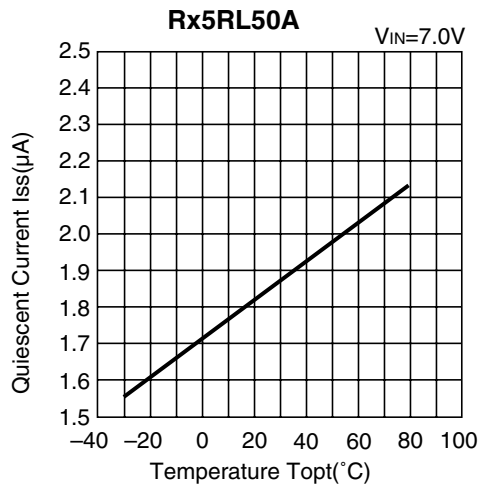

**7) Dropout Voltage vs. Set Output Voltage**

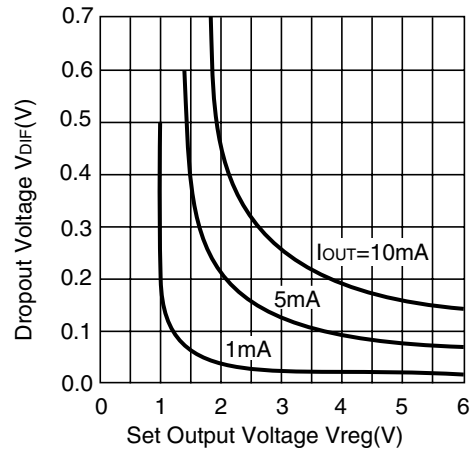

**8) Line Transient Response (1)**

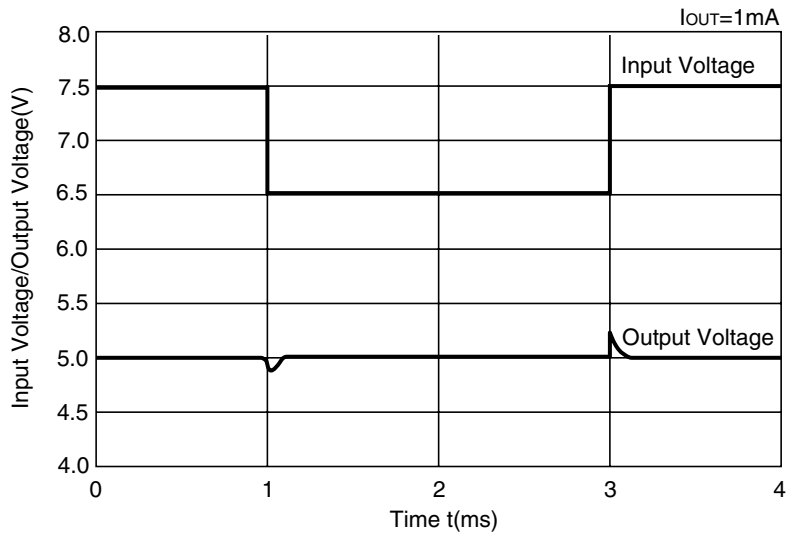

**9) Line Transient Response (2)**

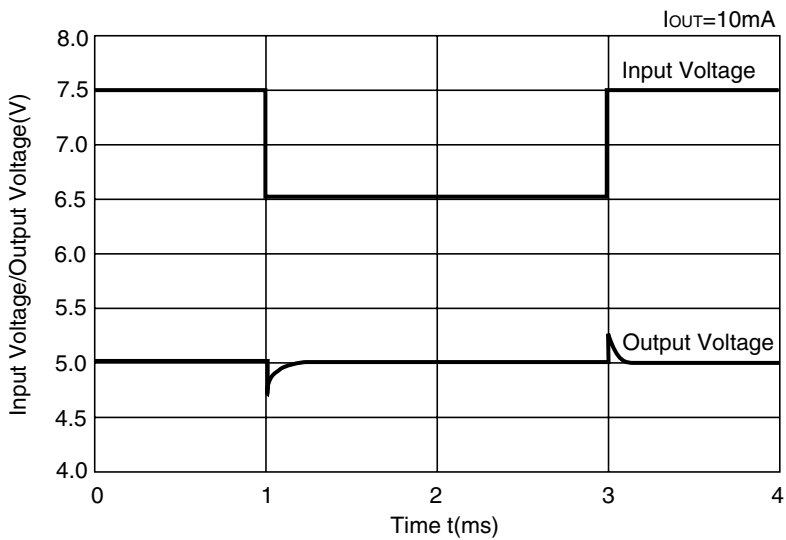

## TYPICAL APPLICATION

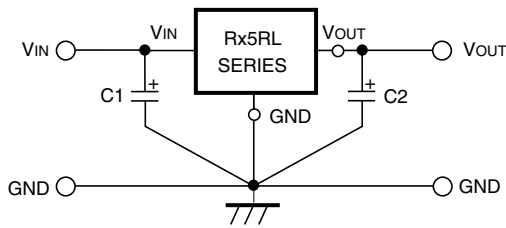

In Rx5RL Series, a constant voltage can be obtained without using Capacitors C1 and C2. However, when the wire connected to Vin is long, use Capacitor C1. Output noise can be reduced by using Capacitor C2.

Insert Capacitors C1 and C2 with the capacitance of 0.1μF to 2.0μF between Input/Output Pins and GND Pin with minimum wiring.

## APPLICATION CIRCUITS

### • VOLTAGE BOOST CIRCUIT

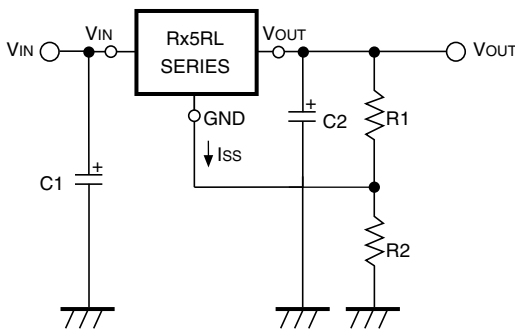

The output voltage can be obtained by the following formula :

$$V_{OUT} = V_{reg}^{*1} \cdot (1 + R_2/R_1) + I_{SS} R \cdot 2$$

Since the quiescent current of Rx5RE Series is so small that the resistances of R1 and R2 can be set as large as several hundreds kΩ and therefore the supply current of “Voltage Boost Circuit” itself can be reduced.

Furthermore, since Rx5RL Series are operated by a constant voltage, the supply current of “Voltage Boost Circuit” is not substantially affected by the input voltage.

■ \*1) Vreg : Set Output Voltage of Rx5RL Series.

### • DUAL POWER SUPPLY CIRCUIT

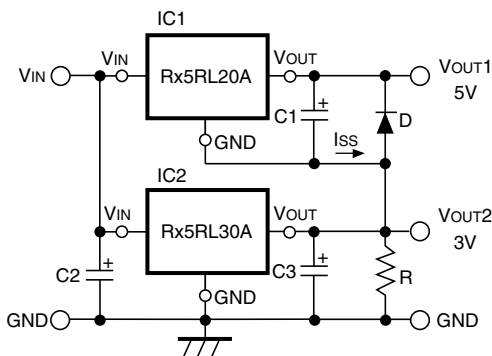

As shown in the circuit diagram, a dual power supply circuit can be constructed by using two Rx5RL Series.

This circuit diagram shows a dual power supply circuit with an output of 3V and an output of 5V. When the minimum output current of IC2 is larger than Iss of IC1, Resistor R is unnecessary. Diode D is a protection diode for the case where VOUT2 becomes larger than VOUT1.



### • CURRENT BOOST CIRCUIT

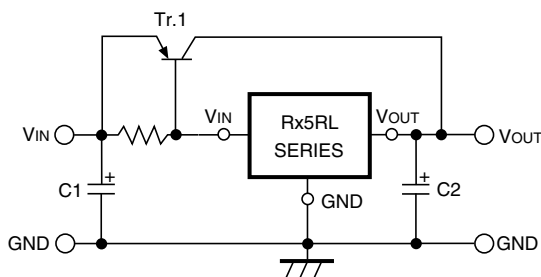

Output current of 60mA or more can be obtained by the current boost circuit constructed as shown in this circuit diagram.

### • CURRENT BOOST CIRCUIT WITH OVERCURRENT LIMIT CIRCUIT

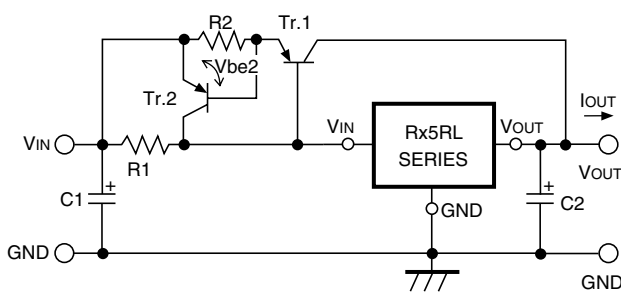

A circuit for protecting Tr.1 from the destruction caused by output short-circuit or overcurrent is shown in this circuit diagram.

When the voltage reduction caused by the current ( $\approx I_{OUT}$ ) which flows through R2 reaches  $V_{be2}$  of Tr.2 by additionally providing the current boost circuit with Tr.2 and R2, Tr.2 is turned on and the base current of Tr.1 is increased, so that the output current is limited.

Current limit of overcurrent limit circuit is obtained as follows :

$$I_{OUT} \approx V_{be2}/R2$$

### • CURRENT SOURCE

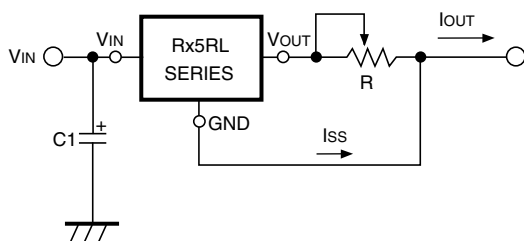

A current source with the structure as shown in this circuit diagram can be used. Output Current  $I_{OUT}$  is obtained as follows :

$$I_{OUT} = V_{reg}^{*1}/R + I_{SS}$$

Output current,  $I_{OUT}$  should not exceed its allowable current.

\*1)  $V_{reg}$  : Set output voltage of Rx5RL Series.