

**LC7930N, 7930NW**
**LCD Drivers**

## Overview

The LC7930N, 7930NW are CMOS LSIs which incorporate 20-bit shift register, latch, and two sets of 20 LCD drivers. They also have two switching pins: one of them (channel 2) can be used as a scan-line driver (back plate) and the other (channel 1) as a segment driver. They are optimal for LCD interface with microcontroller (4 or 8 bits) or dot matrix controller circuit incorporating character generator.

## Features

- Two channels of 20 output segment drivers
- The configuration of 20 output segment drivers + 20 scanning terminal drivers available
- A series data to connect with the microcontroller and three control signals
- Able to be connected in series for large display
- Built-in bidirectional shift register can be shifted in the direction that makes wiring easy
- Operating supply voltage/ Operating temperature:  
 $V_{DD} = 4.5 \text{ to } 5.5 \text{ V}$  /  $T_{opr} = -20 \text{ to } +75^{\circ}\text{C}$
- Operating current drain :  $I_{DD} = 1.0 \text{ mA max}$   
 (Logic = 400 kHz, LCD = 1 kHz)
- Package : Pin 60 Flat LC7930N : QIP60  
 Pin 64 Flat LC7930NW : SQFP64

## Package Dimensions

unit : mm

### 3055A-QFP60C

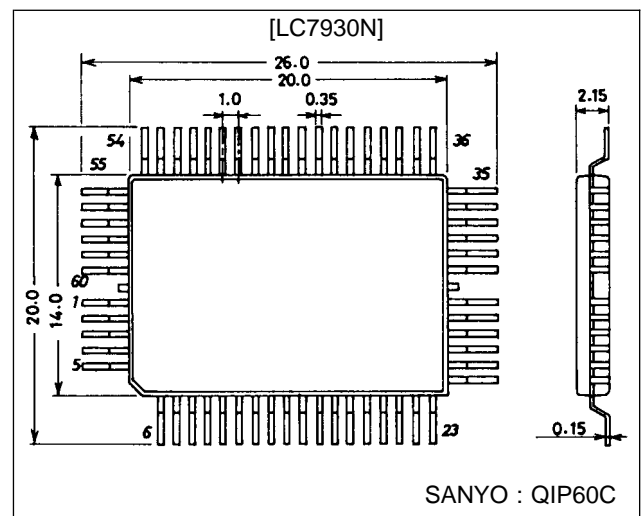

unit : mm

### 3190-SQFP64

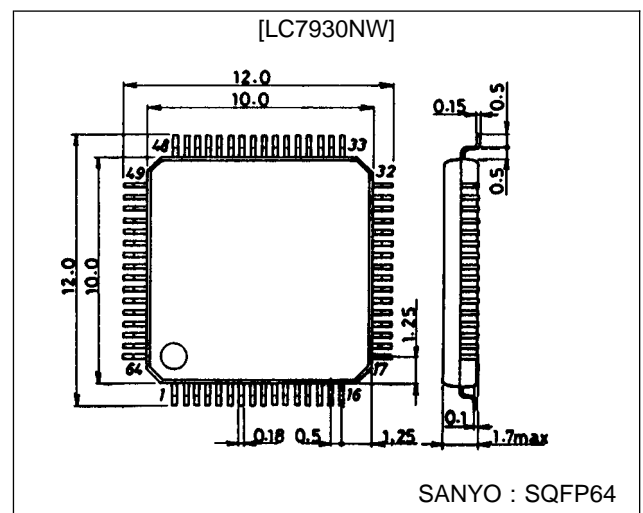

# LC7930N, 7930NW

## Specifications

### Absolute Maximum Ratings at $T_a = 25 \pm 2^\circ\text{C}$

Parameter	Symbol	Conditions	Ratings	Unit
Maximum supply voltage	$V_{DD}$ max		-0.3 to +7.0	V
	$V_{EE}$ max		$V_{DD}-13.5$ to $V_{DD}+0.3$	V
Maximum input voltage	$V_I$ max		-0.3 to $V_{DD}+0.3$	V
		V1, V2, V3, V4, V5, V6	$V_{EE}$ to $V_{DD}+0.3$	V
Maximum output voltage	$V_O$ max		-0.3 to $V_{DD}+0.3$	V
		Output transistor OFF, Y1 to Y40	$V_{EE}$ to $V_{DD}+0.3$	V
Allowable power dissipation	$P_d$ max		100	mW
Operating temperature	$T_{opr}$		-20 to +75	$^\circ\text{C}$
Storage temperature	$T_{stg}$		-55 to +125	$^\circ\text{C}$

Note : Don't soak the whole of IC into the tank filled with melted solder for soldering

### Allowable Operating Conditions at $T_a = -20$ to $+75^\circ\text{C}$ , $V_{SS} = 0$ V, $V_{EE} = -4$ to $-6$ V

Parameter	Symbol	Conditions	min	typ	max	Unit
Supply voltage	$V_{DD}$	$V_{DD}$	4.5		5.5	V
High-level input voltage	$V_{IH}$	Note (1)	$0.7V_{DD}$		$V_{DD}$	V
Low-level input voltage	$V_{IL}$	Note (1)	$V_{SS}$		$0.3V_{DD}$	V
Shift frequency	$f_{CL}$	$CLK_{SR}$			400	kHz
High-level clock width	$t_{CWH}$	$CLK_{SR}$ , $CLK_{LA}$	800			ns
Low-level clock width	$t_{CWL}$	$CLK_{SR}$	800			ns
Data setup time	$t_{SU}$	LDATA1, LDATA2, RDATA1, RDATA2	300			ns
Clock setup time	$t_{SL}$	$CLK_{SR}$ , $CLK_{LA}$ $CLK_{SR} \rightarrow CLK_{LA}$	500			ns
	$t_{LS}$	$CLK_{SR}$ , $CLK_{LA}$ $CLK_{LA} \rightarrow CLK_{SR}$	500			ns
Clock transition time	$t_{ct}$	$CLK_{SR}$ , $CLK_{LA}$			200	ns
Data retention time	$t_{DH}$	LDATA1, LDATA2, RDATA1, RDATA2	300			ns

### Electrical Characteristics at $T_a = -20$ to $+75^\circ\text{C}$ , $V_{DD} = +5$ V $\pm 10\%$ , $V_{SS} = 0$ V, $V_{EE} = -4$ to $-6$ V

Parameter	Symbol	Conditions	min	typ	max	Unit
Input leakage current	$I_{IH}$	Note (1) $V_{in} = V_{DD}$			5	$\mu\text{A}$
	$I_{IL}$	Note (1) $V_{in} = V_{SS}$	-5			$\mu\text{A}$
High-level output voltage	$V_{OH}$	LDATA1, LDATA2, RDATA1, RDATA2 $I_{OH} = -0.4$ mA	$V_{DD}-0.4$			V
Low-level output voltage	$V_{OL}$	LDATA1, LDATA2, RDATA1, RDATA2 $I_{OL} = 0.4$ mA			0.4	V
$V_i$ to $V_j$ voltage down	$V_{d1}$	Y1 to Y40 Note (2) $I_{on} = 100$ $\mu\text{A}$ , single output			1.1	V
	$V_{d2}$	Y1 to Y40 Note (2) $I_{on} = 50$ $\mu\text{A}$ , all outputs			1.5	V
$V_i$ quiescent current	$I_{VH}$	V1 to V6 Open output pins $V_{in} = V_{DD}$			10	$\mu\text{A}$
	$I_{VL}$	V1 to V6 Open output pins $V_{in} = V_{EE}$	-10			$\mu\text{A}$
Supply current	$I_{DD}$	$V_{DD}$ Open output pins $CLK_{SR} = 400$ kHz			1.0	mA
	$I_{EE}$	$V_{EE}$ Open output pins $M = 1$ kHz			10	$\mu\text{A}$
Output propagation delay time	$t_{PD}$	LDATA1, LDATA2, RDATA1, RDATA2 $C_L = 15$ pF			500	ns

Note (1): Applied to the pins;  $CLK_{SR}$ ,  $CLK_{LA}$ , LDATA1, RDATA1, LDATA2, RDATA2, M, L/R1, L/R2, CH2-BP

(2): The equivalent circuit between  $V_i$  to  $V_j$  ( $i = 1$  to  $6$ ,  $j = 1$  to  $40$ )

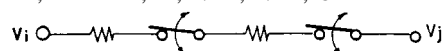

# LC7930N, 7930NW

## Switching Waveforms

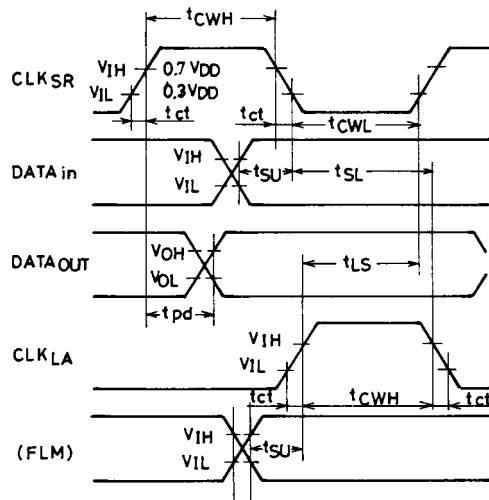

## Internal Equivalent Circuit

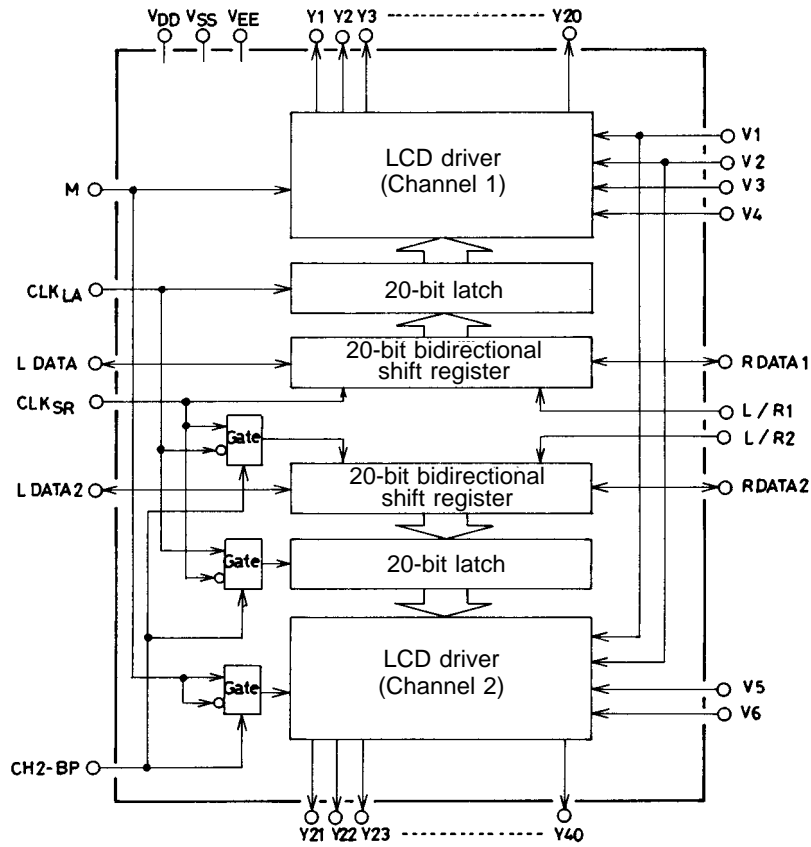

## LC7930N, 7930NW

### Pin Assignment

#### [LC7930N]

Number	Name	Input/Output	Number	Name	Input/Output	Number	Name	Input/Output
1	Y30	Output	21	Y14	Output	41	RDATA1	Input/Output
2	Y31	Output	22	Y13	Output	42	LDATA2	Input/Output
3	Y32	Output	23	Y12	Output	43	RDATA2	Input/Output
4	Y33	Output	24	Y9	Output	44	N.C.	—
5	Y34	Output	25	Y10	Output	45	M	Input
6	Y29	Output	26	Y11	Output	46	L/R1	Input
7	Y28	Output	27	Y8	Output	47	L/R2	Input
8	Y27	Output	28	Y7	Output	48	CH2-BP	Input
9	Y26	Output	29	V <sub>DD</sub>	—	49	V1	Input
10	Y25	Output	30	Y6	Output	50	V2	Input
11	Y24	Output	31	Y5	Output	51	V3	Input
12	Y23	Output	32	Y4	Output	52	V4	Input
13	Y22	Output	33	Y3	Output	53	V5	Input
14	Y21	Output	34	Y2	Output	54	V6	Input
15	Y20	Output	35	Y1	Output	55	Y40	Output
16	Y19	Output	36	V <sub>EE</sub>	—	56	Y39	Output
17	Y18	Output	37	CLK <sub>LA</sub>	Input	57	Y38	Output
18	Y17	Output	38	CLK <sub>SR</sub>	Input	58	Y37	Output
19	Y16	Output	39	V <sub>SS</sub>	—	59	Y36	Output
20	Y15	Output	40	LDATA1	Input/Output	60	Y35	Output

#### [LC7930NW]

Number	Name	Input/Output	Number	Name	Input/Output	Number	Name	Input/Output
1	V5	Input	23	Y6	Output	45	Y26	Output
2	V4	Input	24	V <sub>DD</sub>	—	46	Y27	Output
3	V3	Input	25	Y7	Output	47	Y28	Output
4	V2	Input	26	Y8	Output	48	Y29	Output
5	V1	Input	27	Y11	Output	49	N.C.	—
6	CH2-BP	Input	28	Y10	Output	50	Y34	Output
7	L/R2	Input	29	Y9	Output	51	Y33	Output
8	L/R1	Input	30	Y12	Output	52	Y32	Output
9	M	Input	31	Y13	Output	53	Y31	Output
10	RDATA2	Input/Output	32	N.C.	—	54	Y30	Output
11	LDATA2	Input/Output	33	Y14	Output	55	N.C.	—
12	RDATA1	Input/Output	34	Y15	Output	56	N.C.	—
13	LDATA1	Input/Output	35	Y16	Output	57	Y35	Output
14	V <sub>SS</sub>	—	36	Y17	Output	58	Y36	Output
15	CLK <sub>SR</sub>	Input	37	Y18	Output	59	Y37	Output
16	CLK <sub>LA</sub>	Input	38	Y19	Output	60	Y38	Output
17	V <sub>EE</sub>	—	39	Y20	Output	61	Y39	Output
18	Y1	Output	40	Y21	Output	62	Y40	Output
19	Y2	Output	41	Y22	Output	63	V6	Input
20	Y3	Output	42	Y23	Output	64	N.C.	—
21	Y4	Output	43	Y24	Output			
22	Y5	Output	44	Y25	Output			

# LC7930N, 7930NW

## Pin Descriptions

Pin Name	Function																	
V <sub>DD</sub>	Logic circuitry power supply (+5 V ±10%)																	
V <sub>SS</sub>	0 V																	
V <sub>EE</sub>	LCD driver power supply (−4 to −6 V)																	
Y1 to Y20	Channel 1 LCD driver output pins																	
Y21 to Y40	Channel 2 LCD driver output pins																	
V1, V2	Reference voltage for selected driver outputs																	
V3, V4	Reference voltage for non-selected driver outputs (channel 1)																	
V5, V6	Reference voltage for non-selected driver outputs (channel 2)																	
L/R1	Shift direction for channel 1 shift register <table border="1" style="margin-left: auto; margin-right: auto;"> <thead> <tr> <th>L/R1</th> <th>LDATA1</th> <th>RDATA1</th> </tr> </thead> <tbody> <tr> <td>High-level</td> <td>Output</td> <td>Input</td> </tr> <tr> <td>Low-level</td> <td>Input</td> <td>Output</td> </tr> </tbody> </table>	L/R1	LDATA1	RDATA1	High-level	Output	Input	Low-level	Input	Output								
L/R1	LDATA1	RDATA1																
High-level	Output	Input																
Low-level	Input	Output																
L/R2	Shift direction for channel 2 shift register <table border="1" style="margin-left: auto; margin-right: auto;"> <thead> <tr> <th>L/R2</th> <th>LDATA2</th> <th>RDATA2</th> </tr> </thead> <tbody> <tr> <td>High-level</td> <td>Output</td> <td>Input</td> </tr> <tr> <td>Low-level</td> <td>Input</td> <td>Output</td> </tr> </tbody> </table>	L/R2	LDATA2	RDATA2	High-level	Output	Input	Low-level	Input	Output								
L/R2	LDATA2	RDATA2																
High-level	Output	Input																
Low-level	Input	Output																
LDATA1 RDATA1	Serial data input/output pins for channel 1 shift register																	
LDATA2 RDATA2	Serial data input/output pins for channel 2 shift register																	
M	Switching clock signal for LCD driver.																	
CLK <sub>LA</sub>	Latches channel 1 data on the falling edge. This also will latch channel 2 data on the falling edge if CH2-BP is low.																	
CLK <sub>SR</sub>	Shift channel 1 data on the falling edge. This also will shift channel 2 data on the falling edge if CH2-BP is low.																	
CH2-BP	Switches the mode of channel 2. Exchanges the latch signal for the shift signal of channel 2 and invert the M signal. Channel 2, then, can be used as a scan-line driver. <table border="1" style="margin-left: auto; margin-right: auto;"> <thead> <tr> <th rowspan="2">CH2-BP</th> <th colspan="2">Channel 2</th> <th rowspan="2">M</th> <th rowspan="2"></th> </tr> <tr> <th>Latch</th> <th>Shift</th> </tr> </thead> <tbody> <tr> <td>High</td> <td>CLK<sub>SR</sub> </td> <td>CLK<sub>LA</sub> </td> <td><math>\bar{M}</math></td> <td>For scan-line driver</td> </tr> <tr> <td>Low</td> <td>CLK<sub>LA</sub> </td> <td>CLK<sub>SR</sub> </td> <td>M</td> <td>For signal line driver</td> </tr> </tbody> </table>	CH2-BP	Channel 2		M		Latch	Shift	High	CLK <sub>SR</sub>	CLK <sub>LA</sub>	$\bar{M}$	For scan-line driver	Low	CLK <sub>LA</sub>	CLK <sub>SR</sub>	M	For signal line driver
CH2-BP	Channel 2		M															
	Latch	Shift																
High	CLK <sub>SR</sub>	CLK <sub>LA</sub>	$\bar{M}$	For scan-line driver														
Low	CLK <sub>LA</sub>	CLK <sub>SR</sub>	M	For signal line driver														

## Functional Description

LC7930N, LC7930NW are serial data transfer type LCD drivers.

Data inputted serially from the data pin is shifted successively by the synchronizing clock (CLK<sub>SR</sub>) and latched by the latch clock (CLK<sub>LA</sub>) when the all data are shifted.

- Segment terminal

When CH2-BP goes to low, the data of channel 1 and channel 2 are shifted at the falling edge of CLK<sub>SR</sub>, and then latched at the falling edge of the CLK<sub>LA</sub>. The reference pulse will be switched to selected or unselected due to the latched data.

- Scan terminal

When CH2-BP goes to high, the data of channel 2 is shifted at the rising edge of CLK<sub>LA</sub>, and then latched at the rising edge of the CLK<sub>SR</sub>. When FLM signal, as a data, is inputted, the output will be scan terminal drive mode.

Continued on next page.

## LC7930N, 7930NW

Continued from preceding page.

(1) Waveform Diagrams for Segment Drive Mode (CH2 – BP = “L”)

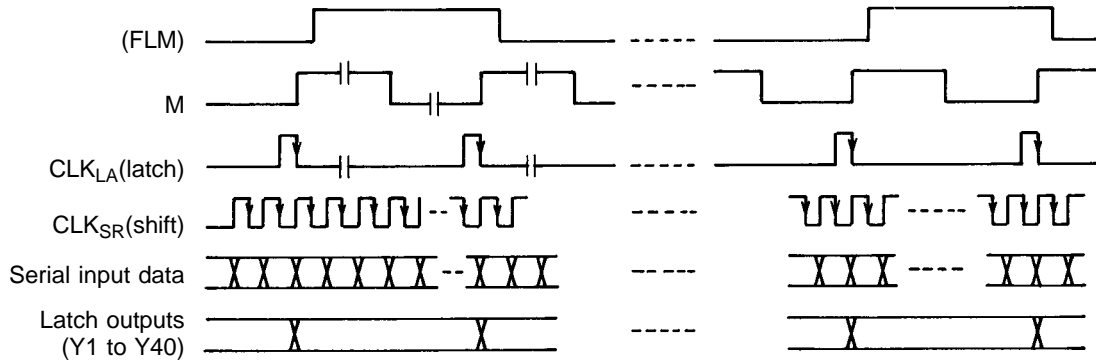

(2) Waveform Diagrams for Scan-Line/Segment Drive Mode (CH2–BP = “H”)

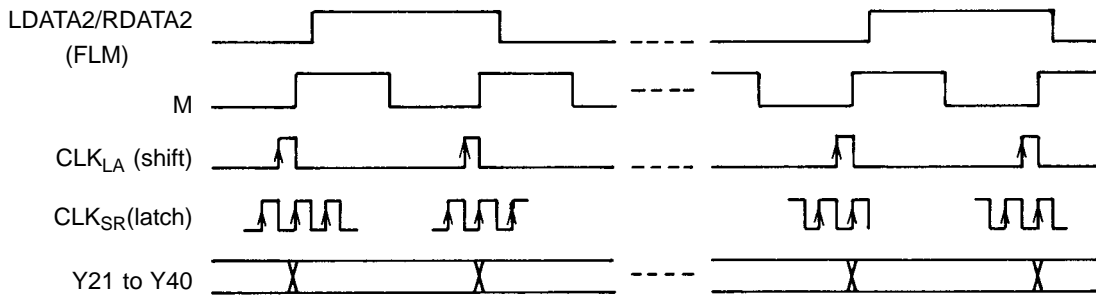

Table 1. LCD Driver Output Voltages (V1 to V6) for Y1 to Y40

CH2–BP	Serial Input Data	M	Output	
			Y1 to Y20	Y21 to Y40
High level (1)	1 (selected)	H	V1	V2
		L	V2	V1
	0 (un-selected)	H	V3	V6
		L	V4	V5
Low level (2)	1	H	V1	V1
		L	V2	V2
	0	H	V3	V5
		L	V4	V6

# LC7930N, 7930NW

## LCD Interface Examples

(Although the LCD divided voltage generator circuit is not shown here.)

(1) 40-segment bar-graph display (static)

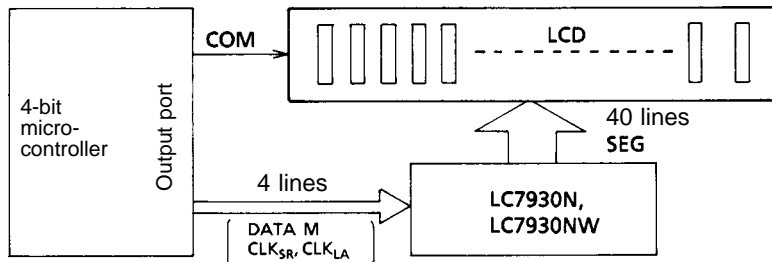

(2) 6-digit, 7-segment + sign display. (1/3 duty cycle, 1/3 voltage bias)

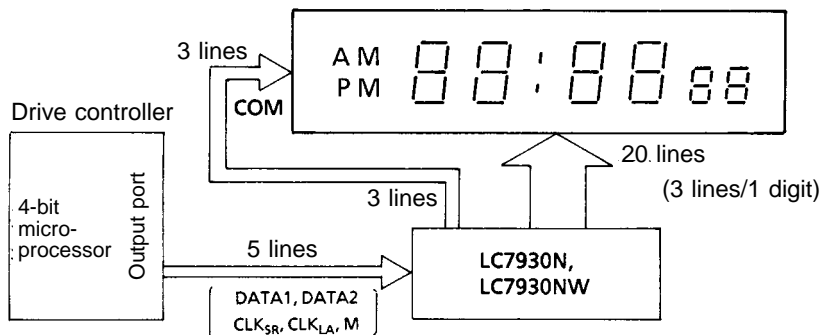

(3) 20 × 60 pixel graphic display. (1/20 duty cycle, 1/5 voltage bias)

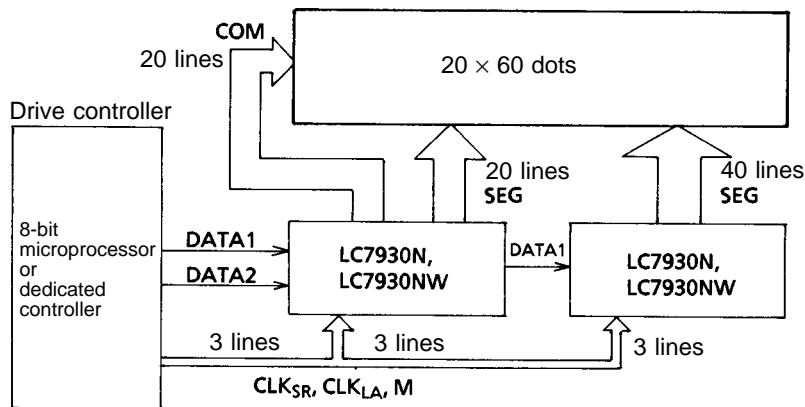

- No products described or contained herein are intended for use in surgical implants, life-support systems, aerospace equipment, nuclear power control systems, vehicles, disaster/crime-prevention equipment and the like, the failure of which may directly or indirectly cause injury, death or property loss.
- Anyone purchasing any products described or contained herein for an above-mentioned use shall:
  - ① Accept full responsibility and indemnify and defend SANYO ELECTRIC CO., LTD., its affiliates, subsidiaries and distributors and all their officers and employees, jointly and severally, against any and all claims and litigation and all damages, cost and expenses associated with such use:
  - ② Not impose any responsibility for any fault or negligence which may be cited in any such claim or litigation on SANYO ELECTRIC CO., LTD., its affiliates, subsidiaries and distributors or any of their officers and employees jointly or severally.
- Information (including circuit diagrams and circuit parameters) herein is for example only; it is not guaranteed for volume production. SANYO believes information herein is accurate and reliable, but no guarantees are made or implied regarding its use or any infringements of intellectual property rights or other rights of third parties.

This catalog provides information as of January, 1997. Specifications and information herein are subject to change without notice.