

Aluminum Capacitors Radial Low Profile 5 mm

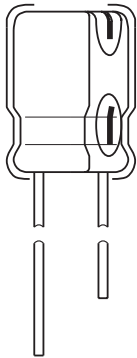
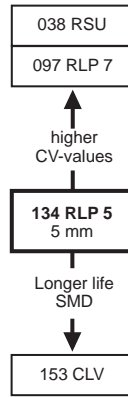

Fig.1 Component outline.



FEATURES

- Polarized aluminum electrolytic capacitors, non-solid electrolyte
- Radial leads, cylindrical aluminum case, insulated with a blue vinyl sleeve
- Charge and discharge proof
- Very low profile, 5 mm height
- Extremely miniaturized.
- Dimensions 3 x 5 and 3.5 x 5 mm are not available in Lead (Pb)-free. For Lead (Pb)-free version, please use the next 4 x 5 mm product instead.



APPLICATIONS

- General purpose, industrial, automotive and audio-video
- Coupling, decoupling, smoothing, filtering and timing
- High mounting density
- Portable and mobile equipment (very small size and very low mass), low profile equipment.

MARKING

The capacitors are marked (where possible) with the following information:

- Rated capacitance (in μF)
- Rated voltage (in V)
- Negative terminal identification
- Code indicating factory of origin
- Name of manufacturer
- Date code, in accordance with IEC 60062.
- Series number (134)

QUICK REFERENCE DATA	
DESCRIPTION	VALUE
Nominal case sizes ($\varnothing D \times L$ in mm)	3 x 5 to 6.3 x 5
Rated capacitance range, C_R	1.0 to 100 μF
Tolerance on C_R	$\pm 20\%$
Rated voltage range, U_R	6.3 to 50 V
Category temperature range	-40 to +85 °C
Endurance test at 85 °C	1000 hours
Useful life at 85 °C	1500 hours
Useful life at 40 °C, 1.4 x IR applied	40000 hours
Shelf life at 0 V, 85 °C	500 hours
Based on sectional specification	IEC 60384-4/EN130300
Climatic category IEC 60068	40/085/56

SELECTION CHART FOR C_R , U_R AND RELEVANT NOMINAL CASE SIZES ($\varnothing D \times L$ in mm)						
C_R (μF)	U_R (V)					
	6.3	10	16	25	35	50
1.0	-	-	-	-	-	3 x 5 ¹⁾ 4 x 5
2.2	-	-	-	-	3 x 5 ¹⁾	3.5 x 5 ¹⁾ 4 x 5
3.3	-	-	-	3 x 5 ¹⁾	-	4 x 5
4.7	-	-	-	3.5 x 5 ¹⁾	4 x 5	5 x 5
10	-	-	3.5 x 5 ¹⁾ 4 x 5	-	5 x 5	6.3 x 5
22	4 x 5	-	5 x 5	-	6.3 x 5	-
33	-	5 x 5	-	6.3 x 5	-	-
47	5 x 5	-	6.3 x 5	-	-	-
100	6.3 x 5	-	-	-	-	-

Note

¹⁾Lead (Pb)-free not available - please select next case size 4 x 5 for Lead (Pb)-free version.

DIMENSIONS in millimeters **AND AVAILABLE FORMS**

 Fig.2 **Form CA:** Long leads.

 Case $\text{ØD} = 3$ and 3.5 mm; pitch $F = 2.5$ mm
 Case $\text{ØD} = 4$ to 6.3 mm; pitch $F = 5$ mm

 Fig.3 **Form TFA:** Taped in box (ammopack)

 pitch $F = 2.5$ mm.
 Case $\text{ØD} = 4$ to 6.3 mm.

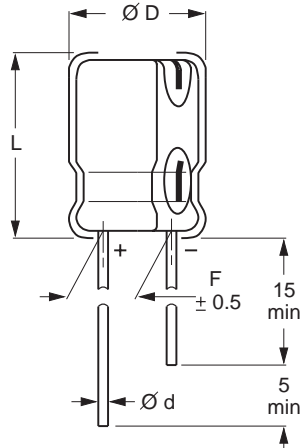
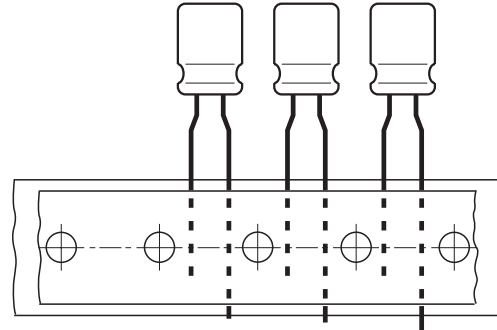
 Fig.4 **Form TNA:** Taped in box (ammopack).

Table 1

DIMENSIONS in millimeters AND PACKAGING QUANTITIES								
NOMINAL CASE SIZE $\text{ØD} \times L$	CASE CODE	Ød	ØD_{max}	L_{max}	F	PACKAGING QUANTITIES		
						FORM CA	FORM TFA	FORM TNA
$3 \times 5^{1)}$	52	0.40	3.5	6.0	1.0 ± 0.3	3000	3000	–
$3.5 \times 5^{1)}$	52	0.40	4.0	6.0	1.0 ± 0.3	3000	3000	–
4×5	53	0.45	4.5	6.0	1.5 ± 0.5	2000	2000	2000
5×5	54	0.45	5.5	6.0	2.0 ± 0.5	2000	2000	2000
6.3×5	55	0.45	6.8	6.0	2.5 ± 0.5	2000	2000	2000

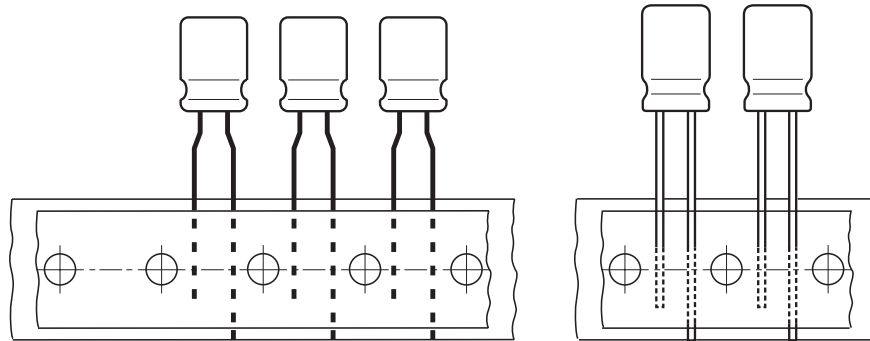
Note
¹⁾Lead (Pb)-free not available - please select next case size 4×5 for Lead (Pb)-free version.

Detailed tape dimensions see section 'PACKAGING'.



ELECTRICAL DATA	
SYMBOL	DESCRIPTION
C_R	rated capacitance at 120 Hz, tolerance $\pm 20\%$
I_R	rated RMS ripple current at 120 Hz, 85 °C
I_{L2}	max. leakage current after 2 minutes at U_R
$\tan \delta$	max. dissipation factor at 120 Hz
Z	max. impedance at 100 kHz

ORDERING EXAMPLE

Electrolytic capacitor 134 series

22 $\mu\text{F}/16\text{ V}; \pm 20\%$

Nominal case size: $\varnothing 5 \times 5\text{ mm}$; Form TFA

Catalog number: 2222 134 35229.

Note

- Unless otherwise specified, all electrical values in Table apply at $T_{\text{amb}} = 20\text{ °C}$, $P = 86\text{ to }106\text{ kPa}$, $\text{RH} = 45\text{ to }75\%$

ELECTRICAL DATA AND ORDERING INFORMATION												
U_R (V)	C_R 120 Hz (μF)	NOMINAL CASE SIZE $\varnothing D \times L$ (mm)	I_R 120 Hz 85 °C (mA)	I_{L2} 2 min (μA)	$\tan \delta$ 120 Hz	Z 100 kHz (Ω)	CATALOG NUMBER 2222 134					
							BULK LONG LEADS		TAPED AMMOPACK			
							FORM CA	F (mm)	FORM TFA	F (mm)	FORM TNA	F (mm)
6.3	22	4 × 5	23	3	0.24	11	53229	1.5	33229	5.0	73229	2.5
	47	5 × 5	38	3	0.24	5.2	53479	2.0	33479	5.0	73479	2.5
	100	6.3 × 5	60	7	0.24	3.4	53101	2.5	33101	5.0	73101	2.5
10	33	5 × 5	35	4	0.20	6.0	54339	2.0	34339	5.0	74339	2.5
16	10	3.5 × 5	17	3	0.16	17	55109 ¹⁾	1.0	35109 ¹⁾	2.5	–	–
	10	4 × 5	20	3	0.16	12	95105	1.5	95103	5.0	95107	2.5
	22	5 × 5	32	4	0.16	6.4	55229	2.0	35229	5.0	75229	2.5
	47	6.3 × 5	50	8	0.16	4.2	55479	2.5	35479	5.0	75479	2.5
25	3.3	3 × 5	9.5	3	0.14	24	56338 ¹⁾	1.0	36338 ¹⁾	2.5	–	–
	4.7	3.5 × 5	12	3	0.14	19	56478 ¹⁾	1.0	36478 ¹⁾	2.5	–	–
	33	6.3 × 5	45	9	0.14	4.6	56339	2.5	36339	5.0	76339	2.5
35	2.2	3 × 5	8.3	3	0.12	41	50228 ¹⁾	1.0	30228 ¹⁾	2.5	–	–
	4.7	4 × 5	15	3	0.12	27	50478	1.5	30478	5.0	70478	2.5
	10	5 × 5	25	4	0.12	17	50109	2.0	30109	5.0	70109	2.5
	22	6.3 × 5	40	8	0.12	11	50229	2.5	30229	5.0	70229	2.5
50	1.0	3 × 5	6.2	3	0.10	50	51108 ¹⁾	1.0	31108 ¹⁾	2.5	–	–
	1.0	4 × 5	7.5	3	0.10	28	91105	1.5	91103	5.0	91107	2.5
	2.2	3.5 × 5	10	3	0.10	33	51228 ¹⁾	1.0	31228 ¹⁾	2.5	–	–
	2.2	4 × 5	12	3	0.10	26	91225	1.5	91223	5.0	91227	2.5
	3.3	4 × 5	14	3	0.10	25	51338	1.5	31338	5.0	71338	2.5
	4.7	5 × 5	19	3	0.10	22	51478	2.0	31478	5.0	71478	2.5
	10	6.3 × 5	29	5	0.10	14	51109	2.5	31109	5.0	71109	2.5

¹⁾Lead (Pb)-free not available - please select next case size 4 x 5 for Lead (Pb)-free version.

ADDITIONAL ELECTRICAL DATA		
DESCRIPTION	CONDITIONS	VALUE
VOLTAGE		
Surge voltage		$U_s \leq 1.15 \times U_R$
Reverse voltage		$U_{\text{rev}} \leq 1\text{ V}$
CURRENT		
Leakage current	after 2 minutes at U_R	$I_{L2} \leq 0.01C_R \times U_R$ or 3 μA (whichever is greater)
RESISTANCE		
Equivalent series resistance (ESR)	calculated from $\tan \delta_{\text{max}}$ and C_R (see Table)	$\text{ESR} = \tan \delta / 2\pi f C_R$

RIPPLE CURRENT AND USEFUL LIFE

Table 2

MULTIPLIER OF RIPPLE CURRENT (I_R) AS A FUNCTION OF FREQUENCY	
FREQUENCY (HZ)	I_R MULTIPLIER
50	0.60
120	1.00
400	1.20
800	1.30
≥ 2000	1.40

 I_A = actual ripple current at 120 Hz.

 I_R = rated ripple current at 120 Hz, 85 °C.

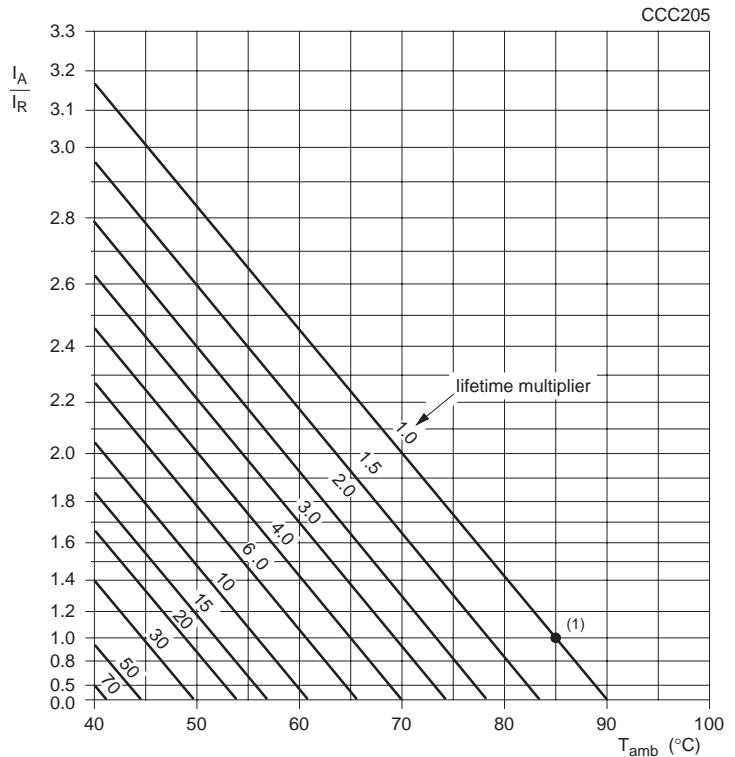
 (1) Useful life at 85 °C and I_R applied: 1500 hours.

Fig.5 Multiplier of useful life as a function of ambient temperature and ripple current load.

Table 3

TEST PROCEDURES AND REQUIREMENTS			
TEST		PROCEDURE (quick reference)	REQUIREMENTS
NAME OF TEST	REFERENCE		
Endurance	IEC 60384-4/ EN130300, subclause 4.13	$T_{amb} = 85\text{ °C}$; U_R applied; 1 000 hours	$\Delta C/C$: $\pm 20\%$ $\tan \delta \leq 2 \times \text{spec. limit}$ $I_{L2} \leq \text{spec. limit}$
Useful life	CECC 30301, subclause 1.8.1	$T_{amb} = 85\text{ °C}$; U_R and I_R applied; 1 500 hours	$\Delta C/C$: $\pm 50\%$ $\tan \delta \leq 3 \times \text{spec. limit}$ $Z \leq 3 \times \text{spec. limit}$ $I_{L2} \leq \text{spec. limit}$ no short or open circuit total failure percentage: $\leq 3\%$
Shelf life (storage at high temperature)	IEC 60384-4/ EN130300, subclause 4.17	$T_{amb} = 85\text{ °C}$; no voltage applied; 500 hours after test: U_R to be applied for 30 minutes, 24 to 48 hours before measurement	$\Delta C/C$, $\tan \delta$, Z : for requirements see 'Endurance test' above $I_{L2} \leq \text{spec. limit}$